



دوره آموزشی SolidWorks مقدماتی



مهدی متقی پور
عضو هیأت علمی دانشگاه صنعتی شریف

Www.sharifcadcam.ir
Sharifcadcam@gmail.com 021-66980854
@sharifcadcam 021-66980926

این جزوه متعلق به موسسه شریف کد کم می باشد. کپی و نشر تمام و یا بخشی از آن غیر قانونی است.

تنها افرادی مجاز به استفاده از این جزوه هستند که دوره آموزشی سالیان دورک مقدماتی را از سایت sharifcadcam.ir خریداری کرده اند.

جزوه جلسه چهارم

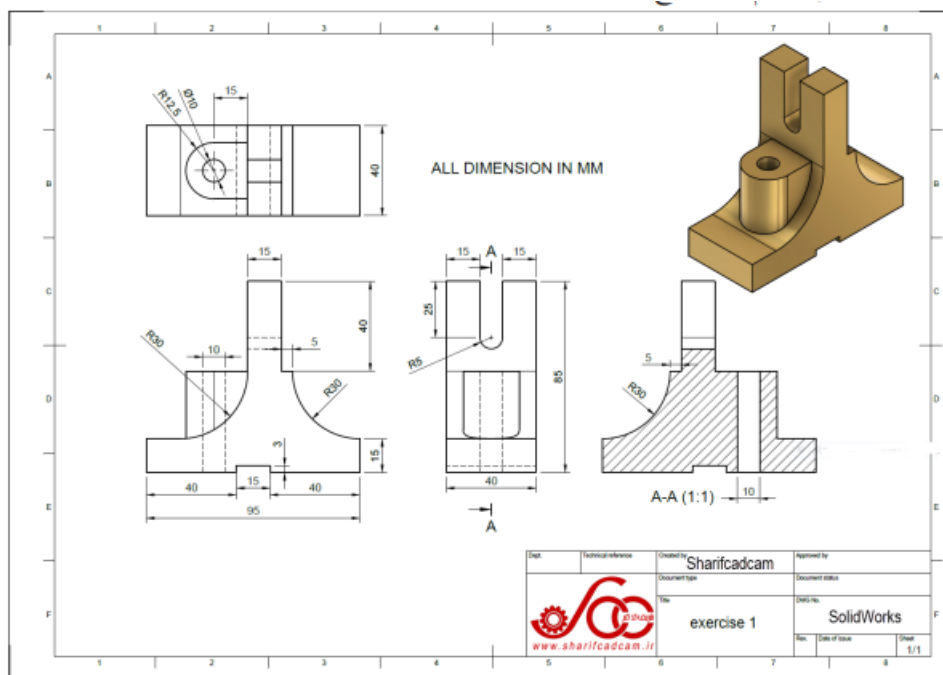
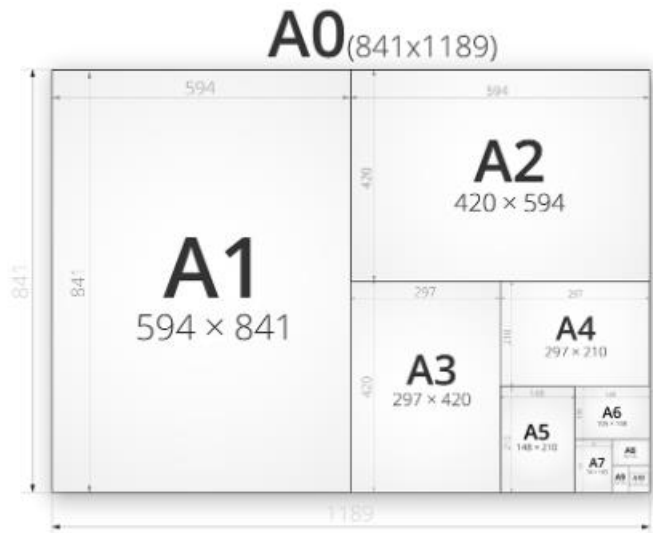

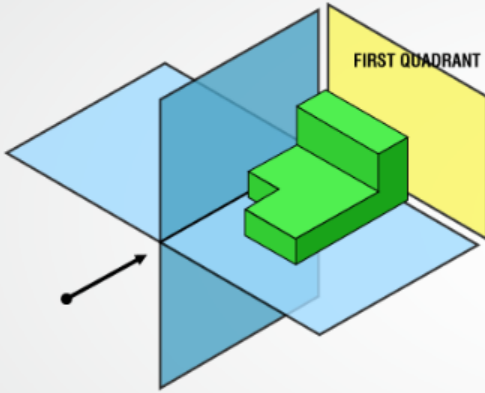

FIRST ANGLE SYSTEM

- EUROPEAN COUNTRIES
- ISO STANDARD
- PLANES ARE OPAQUE

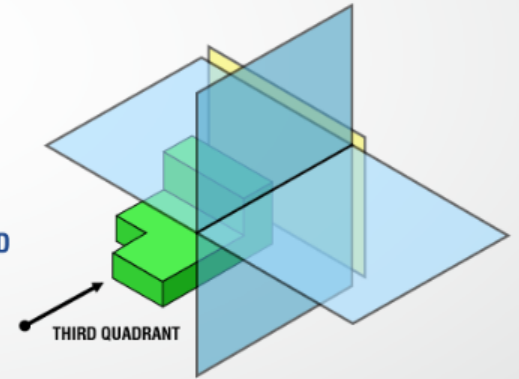

THIRD ANGLE SYSTEM

- CANADA, USA, JAPAN, THAILAND
- PLANES ARE TRANSPARENT

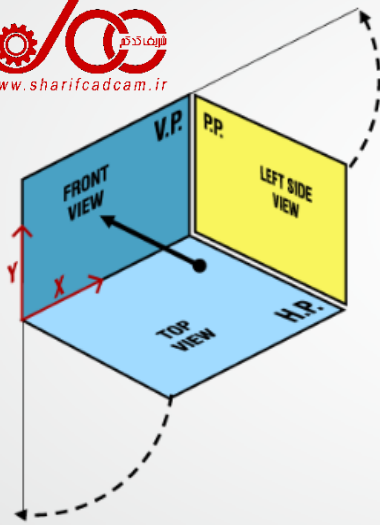

- CONSIDER THAT THE ARROW DIRECTION IS THE NORMAL DIRECTION OF OBSERVING THE OBJECT.
- BUT IN THIS DIRECTION ONLY V.P. AND FRONT VIEW ON V.P. CAN BE SEEN.
- THE OTHER PLANES AND VIEWS ON THOSE CAN NOT BE SEEN.

TO MAKE THOSE PLANES ALSO VISIBLE FROM THE ARROW DIRECTION:

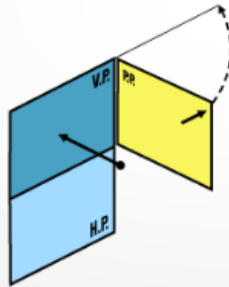

STEP 1
HP IS ROTATED 90° DOWNWARD

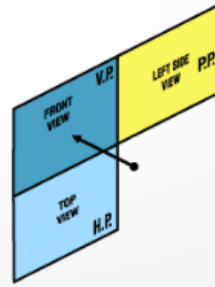

STEP 2
PP IS ROTATED 90° IN RIGHT SIDE

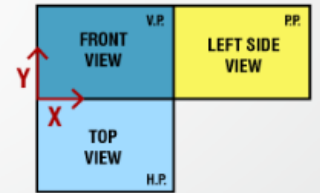

THIS WAY BOTH PLANES ARE BROUGHT IN THE SAME PLANE CONTAINING VP.

FIRST ANGLE SYSTEM

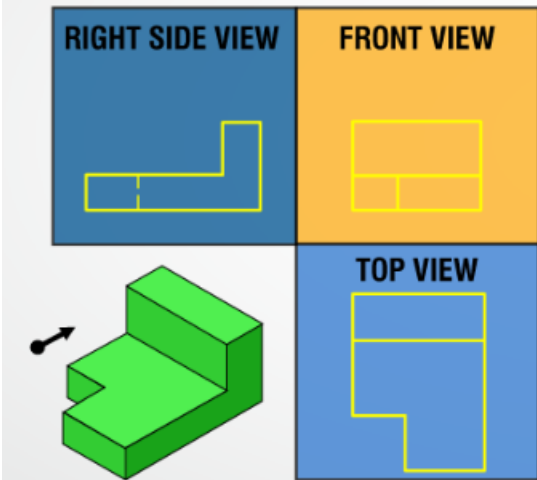

THIRD ANGLE SYSTEM

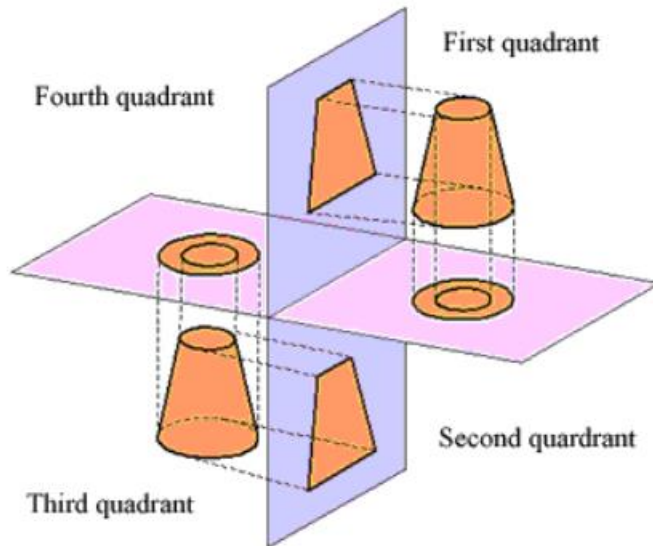
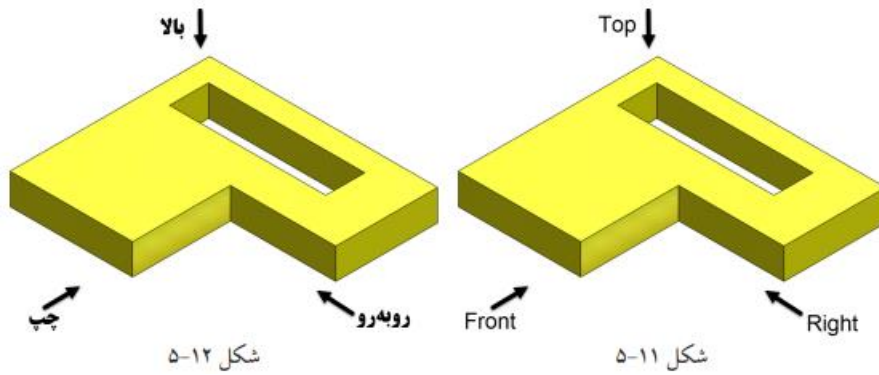
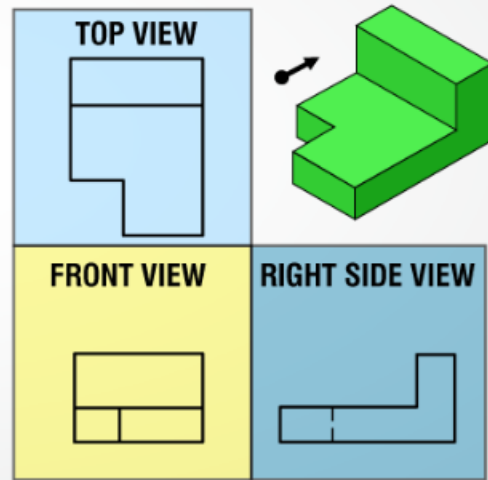

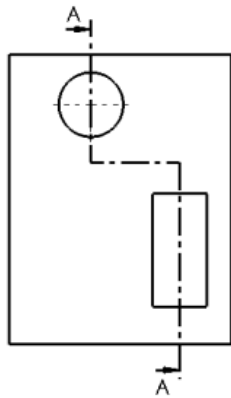

شکل ۵-۳۱



A-A

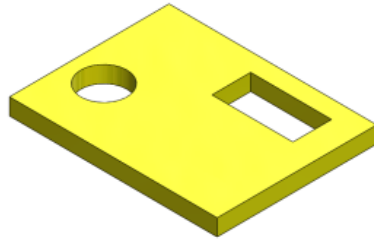

شکل ۵-۳۰

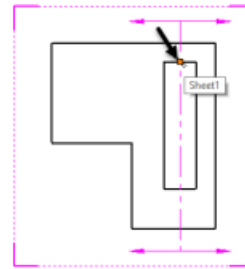

شکل ۵-۲۰

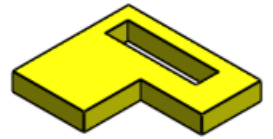

UNLESS OTHERWISE SPECIFIED:		DIMENSIONS ARE IN MILLIMETERS		SURFACE FINISH:		TOLERANCES:		AREAS:		ANGULAR:		DESIGN AND BREAK SHARP EDGES		DO NOT SCALE DRAWING		EDITION	
NAME	SIGNATURE	DATE											TELE:				
BRNFK																	
LNHD																	
APFYD																	
MPG																	
G.A.																	
MATERIAL:										DWG NO. 39		A4					
WEIGHT:				SCALE:				SHEET 3 OF 1									
4				3				2									

شکل ۵-۵۵

