



BSI Standards Publication

**Geometrical product  
specifications (GPS) —  
Geometrical tolerancing —  
Tolerances of form, orientation,  
location and run-out (ISO  
1101:2017)**

**National foreword**

This British Standard is the UK implementation of EN ISO 1101:2017. It supersedes BS EN ISO 1101:2013 which is withdrawn.

The UK participation in its preparation was entrusted to Technical Committee TDW/4, Technical Product Realization.

A list of organizations represented on this committee can be obtained on request to its secretary.

This publication does not purport to include all the necessary provisions of a contract. Users are responsible for its correct application.

© The British Standards Institution 2017.  
Published by BSI Standards Limited 2017

ISBN 978 0 580 87127 6

ICS 01.100.20; 17.040.10; 17.040.40

**Compliance with a British Standard cannot confer immunity from legal obligations.**

This British Standard was published under the authority of the Standards Policy and Strategy Committee on 28 February 2017.

**Amendments/corrigenda issued since publication**

Date	Text affected
------	---------------

---

English Version

Geometrical product specifications (GPS) - Geometrical  
tolerancing - Tolerances of form, orientation, location and  
run-out (ISO 1101:2017)

Spécification géométrique des produits (GPS) -  
Tolérancement géométrique - Tolérancement de  
forme, orientation, position et battement (ISO  
1101:2017)

Geometrische Produktspezifikation (GPS) -  
Geometrische Tolerierung - Tolerierung von Form,  
Richtung, Ort und Lauf (ISO 1101:2017)

This European Standard was approved by CEN on 14 December 2016.

CEN members are bound to comply with the CEN/CENELEC Internal Regulations which stipulate the conditions for giving this European Standard the status of a national standard without any alteration. Up-to-date lists and bibliographical references concerning such national standards may be obtained on application to the CEN-CENELEC Management Centre or to any CEN member.

This European Standard exists in three official versions (English, French, German). A version in any other language made by translation under the responsibility of a CEN member into its own language and notified to the CEN-CENELEC Management Centre has the same status as the official versions.

CEN members are the national standards bodies of Austria, Belgium, Bulgaria, Croatia, Cyprus, Czech Republic, Denmark, Estonia, Finland, Former Yugoslav Republic of Macedonia, France, Germany, Greece, Hungary, Iceland, Ireland, Italy, Latvia, Lithuania, Luxembourg, Malta, Netherlands, Norway, Poland, Portugal, Romania, Serbia, Slovakia, Slovenia, Spain, Sweden, Switzerland, Turkey and United Kingdom.



EUROPEAN COMMITTEE FOR STANDARDIZATION  
COMITÉ EUROPÉEN DE NORMALISATION  
EUROPÄISCHES KOMITEE FÜR NORMUNG

CEN-CENELEC Management Centre: Avenue Marnix 17, B-1000 Brussels

## European foreword

This document (EN ISO 1101-1:2017) has been prepared by Technical Committee ISO/TC 213 “Dimensional and geometrical product specifications and verification” in collaboration with Technical Committee CEN/TC 290 “Dimensional and geometrical product specification and verification” the secretariat of which is held by AFNOR.

This European Standard shall be given the status of a national standard, either by publication of an identical text or by endorsement, at the latest by August 2017 and conflicting national standards shall be withdrawn at the latest by August 2017.

Attention is drawn to the possibility that some of the elements of this document may be the subject of patent rights. CEN [and/or CENELEC] shall not be held responsible for identifying any or all such patent rights.

This document supersedes EN ISO 1101:2013.

According to the CEN-CENELEC Internal Regulations, the national standards organizations of the following countries are bound to implement this European Standard: Austria, Belgium, Bulgaria, Croatia, Cyprus, Czech Republic, Denmark, Estonia, Finland, Former Yugoslav Republic of Macedonia, France, Germany, Greece, Hungary, Iceland, Ireland, Italy, Latvia, Lithuania, Luxembourg, Malta, Netherlands, Norway, Poland, Portugal, Romania, Serbia, Slovakia, Slovenia, Spain, Sweden, Switzerland, Turkey and the United Kingdom.

### Endorsement notice

The text of ISO 1101:2017 has been approved by CEN as EN ISO 1101:2017 without any modification.

# Contents

Page

<b>Foreword</b> .....	<b>vi</b>
<b>Introduction</b> .....	<b>vii</b>
<b>1 Scope</b> .....	<b>1</b>
<b>2 Normative references</b> .....	<b>1</b>
<b>3 Terms and definitions</b> .....	<b>2</b>
<b>4 Basic concepts</b> .....	<b>4</b>
<b>5 Symbols</b> .....	<b>6</b>
<b>6 Toleranced features</b> .....	<b>9</b>
<b>7 Tolerance zones</b> .....	<b>12</b>
7.1 Tolerance zone defaults.....	12
7.2 Tolerance zones of variable width.....	13
7.3 Orientation of tolerance zones for derived features.....	13
7.4 Cylindrical and spherical tolerance zones.....	13
<b>8 Geometrical specification indication</b> .....	<b>14</b>
8.1 General.....	14
8.2 Tolerance indicator.....	14
8.2.1 Symbol section.....	14
8.2.2 Zone, feature and characteristic section.....	14
8.2.3 Datum section.....	35
8.3 Plane and feature indicators.....	35
8.4 Indications adjacent to the tolerance indicator.....	36
8.4.1 General.....	36
8.4.2 Toleranced feature identifiers.....	36
8.4.3 Patterns.....	38
8.4.4 Adjacent indication sequence.....	38
8.5 Stacked tolerance indications.....	38
8.6 Indication of drawing defaults.....	38
<b>9 Supplementary indications</b> .....	<b>39</b>
9.1 Indications of a compound or restricted toleranced feature.....	39
9.1.1 General.....	39
9.1.2 All around and all over — Continuous, closed tolerance feature.....	39
9.1.3 Restricted area toleranced feature.....	42
9.1.4 Continuous, non-closed toleranced feature.....	44
9.2 Moveable assemblies.....	45
<b>10 Theoretically exact dimensions (TED)</b> .....	<b>46</b>
<b>11 Restrictive specifications</b> .....	<b>46</b>
<b>12 Projected toleranced feature</b> .....	<b>48</b>
<b>13 Intersection planes</b> .....	<b>52</b>
13.1 Role of intersection planes.....	52
13.2 Features to be used for establishing a family of intersection planes.....	52
13.3 Graphical language.....	52
13.4 Rules.....	52
<b>14 Orientation planes</b> .....	<b>55</b>
14.1 Role of orientation planes.....	55
14.2 Features to be used for establishing orientation planes.....	55
14.3 Graphical language.....	55
14.4 Rules.....	55
<b>15 Direction feature</b> .....	<b>57</b>

15.1	Role of direction features.....	57
15.2	Features to be used for establishing direction features.....	59
15.3	Graphical language.....	59
15.4	Rules.....	59
<b>16</b>	<b>Collection plane.....</b>	<b>60</b>
16.1	Role of collection planes.....	60
16.2	Features to be used for establishing collection planes.....	61
16.3	Graphical language.....	61
16.4	Rules.....	61
<b>17</b>	<b>Definitions of geometrical specifications.....</b>	<b>61</b>
17.1	General.....	61
17.2	Straightness specification.....	61
17.3	Flatness specification.....	64
17.4	Roundness specification.....	64
17.5	Cylindricity specification.....	66
17.6	Line profile specification not related to a datum.....	67
17.7	Line profile specification related to a datum system.....	68
17.8	Surface profile specification not related to a datum.....	70
17.9	Surface profile specification related to a datum.....	70
17.10	Parallelism specification.....	71
17.10.1	General.....	71
17.10.2	Parallelism specification of a median line related to a datum system.....	72
17.10.3	Parallelism specification of a median line related to a datum straight line.....	75
17.10.4	Parallelism specification of a median line related to a datum plane.....	76
17.10.5	Parallelism specification of a set of lines in a surface related to a datum plane.....	77
17.10.6	Parallelism specification of a planar surface related to a datum straight line.....	77
17.10.7	Parallelism specification of a planar surface related to a datum plane.....	78
17.11	Perpendicularity specification.....	79
17.11.1	General.....	79
17.11.2	Perpendicularity specification of a median line related to a datum straight line.....	79
17.11.3	Perpendicularity specification of a median line related to a datum system.....	80
17.11.4	Perpendicularity specification of a median line related to a datum plane.....	82
17.11.5	Perpendicularity specification of a planar surface related to a datum straight line.....	83
17.11.6	Perpendicularity specification of a planar surface related to a datum plane.....	83
17.12	Angularity specification.....	84
17.12.1	General.....	84
17.12.2	Angularity specification of a median line related to a datum straight line.....	84
17.12.3	Angularity specification for a median line related to a datum system.....	86
17.12.4	Angularity specification for a planar surface related to a datum straight line.....	87
17.12.5	Angularity specification for a planar surface related to a datum plane.....	88
17.13	Position specification.....	89
17.13.1	General.....	89
17.13.2	Position specification of a derived point.....	89
17.13.3	Position specification of a median line.....	90
17.13.4	Position specification of a median plane.....	94
17.13.5	Position specification of a planar surface.....	96
17.14	Concentricity and coaxiality specification.....	97
17.14.1	General.....	97
17.14.2	Concentricity specification of a point.....	97
17.14.3	Coaxiality specification of an axis.....	98
17.15	Symmetry specification.....	100
17.15.1	General.....	100
17.15.2	Symmetry specification of a median plane.....	100
17.16	Circular run-out specification.....	101
17.16.1	General.....	101
17.16.2	Circular run-out specification — Radial.....	101

17.16.3	Circular run-out specification — Axial	103
17.16.4	Circular runout in any direction	104
17.16.5	Circular run-out specification in a specified direction	106
17.17	Total run-out specification	107
17.17.1	General	107
17.17.2	Total run-out specification — Radial	107
17.17.3	Total run-out specification – Axial	108
<b>Annex A</b>	<b>(informative) Deprecated and former practices</b>	<b>110</b>
<b>Annex B</b>	<b>(informative) Explicit and implicit rules for geometrical tolerance zones</b>	<b>119</b>
<b>Annex C</b>	<b>(informative) Filters</b>	<b>125</b>
<b>Annex D</b>	<b>(normative) ISO special specification elements for form</b>	<b>128</b>
<b>Annex E</b>	<b>(informative) Filter details</b>	<b>129</b>
<b>Annex F</b>	<b>(normative) Relations and dimensions of graphical symbols</b>	<b>142</b>
<b>Annex G</b>	<b>(informative) Relation to the GPS matrix model</b>	<b>144</b>
<b>Bibliography</b>		<b>145</b>

## Foreword

ISO (the International Organization for Standardization) is a worldwide federation of national standards bodies (ISO member bodies). The work of preparing International Standards is normally carried out through ISO technical committees. Each member body interested in a subject for which a technical committee has been established has the right to be represented on that committee. International organizations, governmental and non-governmental, in liaison with ISO, also take part in the work. ISO collaborates closely with the International Electrotechnical Commission (IEC) on all matters of electrotechnical standardization.

The procedures used to develop this document and those intended for its further maintenance are described in the ISO/IEC Directives, Part 1. In particular the different approval criteria needed for the different types of ISO documents should be noted. This document was drafted in accordance with the editorial rules of the ISO/IEC Directives, Part 2 (see [www.iso.org/directives](http://www.iso.org/directives)).

Attention is drawn to the possibility that some of the elements of this document may be the subject of patent rights. ISO shall not be held responsible for identifying any or all such patent rights. Details of any patent rights identified during the development of the document will be in the Introduction and/or on the ISO list of patent declarations received (see [www.iso.org/patents](http://www.iso.org/patents)).

Any trade name used in this document is information given for the convenience of users and does not constitute an endorsement.

For an explanation on the meaning of ISO specific terms and expressions related to conformity assessment, as well as information about ISO's adherence to the World Trade Organization (WTO) principles in the Technical Barriers to Trade (TBT) see the following URL: [www.iso.org/iso/foreword.html](http://www.iso.org/iso/foreword.html).

This document was prepared by Technical Committee ISO/TC 213, *Dimensional and geometrical product specifications and verifications*.

This fourth edition cancels and replaces the third edition (ISO 1101:2012), which has been technically revised.

It also incorporates the Technical Corrigendum ISO 1101:2012/Cor.1:2013.

The main changes are as follows.

- Tools have been added to specify the filtering of the toleranced feature and a line type has been designated for its illustration.
- Tools have been added to tolerance associated features.
- Tools have been added to specify form characteristics by specifying the reference feature association and the specified parameter.
- Tools have been added to specify the constraints to the tolerance zone.
- The rules for specifications using “all around” or “all over” modifiers have been clarified.
- The direction of the tolerance zone in the case of roundness tolerances for revolute surfaces that are neither cylindrical nor spherical, e.g. cones shall now always be indicated to avoid an exception to the general rule that specifications for integral features apply perpendicular to the surface.
- The “from-to” symbol has been retired and replaced by the “between” symbol.



## Introduction

This document is a geometrical product specification (GPS) standard and is to be regarded as a general GPS standard (see ISO 14638). It influences chain links A, B and C of the chain of standards on form, orientation, location and run out.

The ISO GPS Masterplan given in ISO 14638 gives an overview of the ISO GPS system of which this document is a part. The fundamental rules of ISO GPS given in ISO 8015 apply to this document. The default decision rules given in ISO 14253-1 apply to specifications made in accordance with this document, unless otherwise stated.

For more detailed information on the relation of this document to the GPS matrix model, see [Annex G](#).

This document represents the initial basis and describes the required fundamentals for geometrical tolerancing. Nevertheless, it is advisable to consult the separate standards referenced in [Clause 2](#) and in [Tables 3](#) and [4](#) for more detailed information.

For the presentation of lettering (proportions and dimensions), see ISO 3098-2.

All figures in this document for the 2D drawing indications have been drawn in first-angle projection with dimensions and tolerances in millimetres. It should be understood that third-angle projection and other units of measurement could have been used equally well without prejudice to the principles established. For all figures giving specification examples in 3D, the dimensions and tolerances are the same as for the similar figures shown in 2D.

The figures in this document represent either 2D drawing views or 3D axonometric views on 2D drawings and are intended to illustrate how a specification can be fully indicated with visible annotation. For possibilities of illustrating a specification where elements of the specification may be available through a query function or other interrogation of information on the 3D CAD model and rules for attaching specifications to 3D CAD models, see ISO 16792.

The figures in this document illustrate the text and are not intended to reflect an actual application. Consequently, the figures are not fully dimensioned and specified, showing only the relevant general principles. Neither are the figures intended to imply a particular display requirement in terms of whether hidden detail, tangent lines or other annotations are shown or not shown. Many figures have lines or details removed for clarity, or added or extended to assist with the illustration of the text. See [Table 1](#) for the line types used in definition figures.

In order for a GPS specification to be unambiguous, the partition defining the boundary of the toleranced feature, as well as the filtering, has to be well defined. Currently, the detailed rules for partitioning and the default for filtering are not defined in GPS standards.

For a definitive presentation (proportions and dimensions) of the symbolization for geometrical tolerancing, see ISO 7083 and [Annex F](#).

[Annex A](#) has been provided for information only. It presents previous drawing indications that have been omitted here and are no longer used.

For the purposes of this document, the terms “axis” and “median plane” are used for derived features of perfect form, and the terms “median line” and “median surface” for derived features of imperfect form. Furthermore, the following line types have been used in the explanatory illustrations, i.e. those representing non-technical drawings for which the rules of ISO 128 (all parts) apply.

**Table 1**

Feature level	Feature type	Details	Line type	
			Visible	Behind plane/surface
Nominal feature	integral feature	point line/axis surface/plane	wide continuous	narrow dashed
	derived feature	point line/axis surface/plane	narrow long dashed dotted	narrow dashed dotted
Real feature	integral feature	surface	wide freehand con- tinuous	narrow freehand dashed
Extracted feature	integral feature	point line surface	wide short dashed	narrow short dashed
	derived feature	point line surface	wide dotted	narrow dotted
Filtered feature	integral feature	line surface	continuous narrow	continuous narrow
Associated feature	integral feature	point straight line plane	wide doubled-dashed double-dotted	narrow dou- ble-dashed dou- ble-dotted
	derived feature	point straight line (axis) plane	narrow long dashed double-dotted	wide dashed double-dotted
	datum	point line/axis surface/plane	wide long dashed double-short dashed	narrow long dashed double-short dashed
Tolerance zone limits, tolerance planes		line surface	continuous narrow	narrow dashed
Section, illustration plane, drawing plane, aid plane		line surface	narrow long dashed short dashed	narrow dashed short dashed
Extension, dimension, leader and reference lines		line	continuous narrow	narrow dashed

# Geometrical product specifications (GPS) — Geometrical tolerancing — Tolerances of form, orientation, location and run-out

**IMPORTANT** — The illustrations included in this document are intended to illustrate the text and/or to provide examples of the related technical drawing specification; these illustrations are not fully dimensioned and toleranced, showing only the relevant general principles. In particular, many illustrations do not contain filter specifications. As a consequence, the illustrations are not a representation of a complete workpiece, and are not of a quality that is required for use in industry (in terms of full conformity with the standards prepared by ISO/TC 10 and ISO/TC 213), and as such are not suitable for projection for teaching purposes.

## 1 Scope

This document defines the symbol language for geometrical specification of workpieces and the rules for its interpretation.

It provides the foundation for geometrical specification.

The illustrations in this document are intended to illustrate how a specification can be fully indicated with visible annotation (including e.g. TEDs).

NOTE 1 Other International Standards referenced in [Clause 2](#) and in [Tables 3](#) and [4](#) provide more detailed information on geometrical tolerancing.

NOTE 2 This document gives rules for explicit and direct indications of geometrical specifications. Alternatively, the same specifications can be indicated indirectly in accordance with ISO 16792 by attaching them to a 3D CAD model. In this case, it is possible that some elements of the specification are available through a query function or other interrogation of information on the model instead of being indicated using visible annotation.

## 2 Normative references

The following documents are referred to in the text in such a way that some or all of their content constitutes requirements of this document. For dated references, only the edition cited applies. For undated references, the latest edition of the referenced document (including any amendments) applies.

ISO 128-24:1999, *Technical drawings — General principles of presentation — Part 24: Lines on mechanical engineering drawings*

ISO 1660, *Technical drawings — Dimensioning and tolerancing of profiles*

ISO 2692:2014, *Geometrical product specifications (GPS) — Geometrical tolerancing — Maximum material requirement (MMR), least material requirement (LMR) and reciprocity requirement (RPR)*

ISO 5458, *Geometrical Product Specifications (GPS) — Geometrical tolerancing — Positional tolerancing*

ISO 5459, *Geometrical product specifications (GPS) — Geometrical tolerancing — Datums and datum systems*

ISO 8015:2011, *Geometrical product specifications (GPS) — Fundamentals — Concepts, principles and rules*

ISO 10579:2010, *Geometrical product specifications (GPS) — Dimensioning and tolerancing — Non-rigid parts*

ISO 13715, *Technical drawings — Edges of undefined shape — Vocabulary and indications*

ISO 16610 (all parts), *Geometrical product specifications (GPS) — Filtration*

ISO 17450-1:2011, *Geometrical product specifications (GPS) — General concepts — Part 1: Model for geometrical specification and verification*

ISO 17450-2, *Geometrical product specifications (GPS) — General concepts — Part 2: Basic tenets, specifications, operators, uncertainties and ambiguities*

ISO 17450-3, *Geometrical product specifications (GPS) — General concepts — Part 3: Toleranced features*

ISO 22432, *Geometrical product specifications (GPS) — Features utilized in specification and verification*

ISO 25378:2011, *Geometrical product specifications (GPS) — Characteristics and conditions — definitions*

### 3 Terms and definitions

For the purpose of this document, the terms and definitions given in ISO 8015, the ISO 16610 series, ISO 17450-1, ISO 17450-2, ISO 17450-3, ISO 22432, ISO 25378 and the following apply.

ISO and IEC maintain terminological databases for use in standardization at the following addresses:

- IEC Electropedia: available at <http://www.electropedia.org/>
- ISO Online browsing platform: available at <https://www.iso.org/obp/>

**3.1 tolerance zone**  
space limited by and including one or two ideal lines or surfaces, and characterized by one or more linear dimensions, called a tolerance

Note 1 to entry: See also 4.4.

**3.2 intersection plane**  
plane, established from an extracted feature of the workpiece, identifying a line on an extracted surface (integral or median) or a point on an extracted line

Note 1 to entry: The use of intersection planes makes it possible to define toleranced features independent of the view.

Note 2 to entry: For areal surface texture, the intersection plane can be used to define the orientation of the evaluation area, see ISO 25178-1.

**3.3 orientation plane**  
plane, established from an extracted feature of the workpiece, identifying the orientation of the tolerance zone

Note 1 to entry: The use of an orientation plane makes it possible to define the direction of the planes or cylinder that limit the tolerance zone independent of the TEDs (for location) or of the datum (for orientation). The orientation plane is only used for this purpose when the toleranced feature is a median feature (centre point, median straight line) and the tolerance zone is defined by two parallel straight lines or two parallel planes or, for a centre point, a cylinder.

Note 2 to entry: The use of an orientation plane also makes it possible to define the orientation of a rectangular restricted area.

### 3.4 direction feature

ideal feature, established from an extracted feature of the workpiece, identifying the direction of local deviations

Note 1 to entry: The direction feature can be a plane, a cylinder or a cone.

Note 2 to entry: For a line in a surface, the use of a direction feature makes it possible to change the direction of the width of the tolerance zone.

Note 3 to entry: The direction feature is used when the tolerance value applies in a specified direction instead of normal to the specified geometry.

Note 4 to entry: The direction feature is constructed from the datum indicated in the second compartment of the direction feature indicator. The geometry of the direction feature depends on the geometry of the tolerated feature.

### 3.5 compound continuous feature

single feature composed of more than one single feature joined together without gaps

Note 1 to entry: A compound continuous feature can be closed or not.

Note 2 to entry: A non-closed compound continuous feature can be defined using the “between” symbol (see 9.1.4) and, if applicable, the UF modifier.

Note 3 to entry: A closed compound continuous feature can be defined using the “all around” symbol (see 9.1.2) and the UF modifier. In this case, it is a set of single features whose intersection with any plane parallel to a collection plane is a line or a point.

Note 4 to entry: A closed compound continuous feature can be defined using the “all over” symbol (see 9.1.2) and the UF modifier.

### 3.6 collection plane

plane, established from a feature on the workpiece, defining a closed compound continuous feature

Note 1 to entry: The collection plane is always used when the “all around” symbol is applied.

### 3.7 theoretically exact dimension TED

linear or angular dimension used in GPS operations to define theoretically exact geometry, extents, locations and orientations of features

Note 1 to entry: For the purpose of this document, the term “theoretically exact dimension” has been abbreviated as TED.

Note 2 to entry: A TED can be used to define the following:

- the nominal shape and dimensions of features;
- the definition of theoretically exact features (TEF);
- the location and dimensions of portions of features, including restricted tolerated features;
- the length of projected tolerated features;
- the relative location and orientation of two or more tolerance zones;
- the relative location and orientation of datum targets, including moveable datum targets;
- the location and orientation of tolerance zones relative to datums and datum systems;
- the direction of the width of tolerance zones.

Note 3 to entry: A TED can be explicit or implicit. When indicated, an explicit TED is indicated by a rectangular frame including a value and sometimes an associated symbol, e.g.  $\varnothing$  or R. On 3D models, explicit TEDs may be available by queries.

Note 4 to entry: An implicit TED is not indicated. An implicit TED is one of the following: 0 mm, 0°, 90°, 180°, 270° and the angular distance between equally spaced features on a complete circle.

Note 5 to entry: TEDs are not affected by individual or general specifications.

### 3.8 theoretically exact feature TEF

nominal feature with ideal shape, size, orientation and location, as applicable

Note 1 to entry: A theoretically exact feature (TEF) can have any shape and can be defined by explicitly indicated theoretically exact dimensions (TEDs) or implicitly defined in CAD data.

Note 2 to entry: The theoretically exact location and orientation, if applicable, is relative to the indicated datum system for the specification of the corresponding actual feature.

Note 3 to entry: See also ISO 25378.

EXAMPLE 1 The spherical surface shown in [Figure 110](#) is a theoretically exact feature, with a defined spherical radius and a defined location and orientation relative to datum A.

EXAMPLE 2 A virtual condition, e.g. a maximum material virtual condition (MMVC) according to ISO 2692 is a theoretically exact feature.

### 3.9 united feature

compound integral feature which may or may not be continuous, considered as a single feature

Note 1 to entry: A united feature can have a derived feature.

Note 2 to entry: The definition of a united feature is intentionally very broad to avoid excluding any useful applications. However, it is not intended that a united feature can be used to define something that is by nature several separate features. For example, building a united feature from two parallel, non-coaxial cylindrical features, or two parallel, non-coaxial rectangular tubes (each built from two perpendicular pairs of parallel planes) is not an intended use.

EXAMPLE 1 A cylindrical feature defined from a set of arc features, such as the outside diameter of a spline, is an intended use of a united feature, see [Figure 48](#).

EXAMPLE 2 Two complete coaxial cylinders, which do not have the same nominal diameter, cannot be considered as a united feature.

## 4 Basic concepts

4.1 Geometrical tolerances shall be specified in accordance with functional requirements. Manufacturing and inspection requirements can also influence geometrical tolerancing.

NOTE Indicating geometrical tolerances does not necessarily imply the use of any particular method of production, measurement or gauging.

4.2 A geometrical tolerance applied to a feature defines the tolerance zone around the reference feature within which the toleranced feature shall be contained.

NOTE 1 In some cases, i.e. when using the characteristic parameter modifiers introduced in this document, see [Figure 13](#), geometrical specifications can define characteristics instead of zones.

NOTE 2 All dimensions given in the figures in this document are in millimetres.

**4.3** A feature is a specific portion of the workpiece, such as a point, a line or a surface; these features can be integral features (e.g. the external surface of a cylinder) or derived features (e.g. a median line or median surface). See ISO 17450-1.

**4.4** Depending on the characteristic to be specified and the manner in which it is specified, the tolerance zone is one of the following:

- the space within a circle;
- the space between two concentric circles;
- the space between two parallel circles on a conical surface;
- the space between two parallel circles of the same diameter;
- the space between two equidistant complex lines or two parallel straight lines;
- the space between two non-equidistant complex lines or two non-parallel straight lines;
- the space within a cylinder;
- the space between two coaxial cylinders;
- the space within a cone;
- the space within a single complex surface;
- the space between two equidistant complex surfaces or two parallel planes;
- the space within a sphere;
- the space between two non-equidistant complex surfaces or two non-parallel planes.

NOTE The tolerance zone may be defined in the CAD model.

**4.5** Unless a more restrictive indication is required, for example by an explanatory note, the toleranced feature may be of any form, orientation and/or location within this tolerance zone.

**4.6** The specification applies to the whole extent of the considered feature unless otherwise specified. See [Clauses 11](#) and [12](#).

Currently, the detailed rules for partitioning (defining the boundary of the toleranced feature) are not elaborated in GPS standards. This leads to an ambiguity of specification.

**4.7** Geometrical specifications which are assigned to features related to a datum(s) do not limit the form deviations of the datum feature(s) itself.

**4.8** For functional reasons, one or more characteristics can be specified to define the geometrical deviations of a feature. Certain types of specifications, which limit the geometrical deviations of a toleranced feature, can also limit other types of deviations for the same feature.

- A location specification controls location deviation, orientation deviation and form deviation of the toleranced feature.
- An orientation specification controls orientation and form deviations of the toleranced feature but cannot control its location.
- A form specification controls only form deviations of the toleranced feature.

## 5 Symbols

The symbols used in symbol section of the tolerance indicator are defined in [Table 2](#).

The symbols used in zone, feature and characteristic section of the tolerance indicator are defined in [Table 3](#). [Annex C](#) defines the meaning of the filtration symbols and [Annex D](#) defines the meaning of association symbol and parameter (of characteristic) symbols.

Some symbols defined in other standards and used in ISO 1101 are presented in [Table 4](#) for information.

For filter symbols, see [Table C.1](#); for nesting indices, see [Table C.2](#); for association symbols, see [Table D.1](#); and for parameter symbols, see [Table D.2](#).

NOTE For symbol proportions, see ISO 7083 and [Annex F](#).

**Table 2 — Symbols for geometrical characteristics**











Specification	Characteristics	Symbol	Datum needed	Subclause
Form	Straightness	—	no	<a href="#">17.2</a>
	Flatness	▭	no	<a href="#">17.3</a>
	Roundness	○	no	<a href="#">17.4</a>
	Cylindricity	∅	no	<a href="#">17.5</a>
	Line profile	∩ <sup>a</sup>	no	<a href="#">17.6</a>
	Surface profile	∪ <sup>a</sup>	no	<a href="#">17.8</a>
Orientation	Parallelism	//	yes	<a href="#">17.10</a>
	Perpendicularity	⊥	yes	<a href="#">17.11</a>
	Angularity	∠	yes	<a href="#">17.12</a>
	Line profile	∩ <sup>a</sup>	yes	
	Surface profile	∪ <sup>a</sup>	yes	
Location	Position	⊕	no	b
			yes	<a href="#">17.13</a>
	Concentricity (for centre points)	◎	yes	<a href="#">17.14</a>
	Coaxiality (for median lines)	◎	yes	<a href="#">17.14</a>
	Symmetry	≡	yes	<a href="#">17.15</a>
	Line profile	∩ <sup>a</sup>	yes	<a href="#">17.7</a>
Surface profile	∪ <sup>a</sup>	yes	<a href="#">17.9</a>	
Run-out	Circular run-out	↗	yes	<a href="#">17.16</a>
	Total run-out	↗↗	yes	<a href="#">17.17</a>
NOTE 1 The line profile specification symbol was called “profile any line” in former versions of this document.				
NOTE 2 The surface profile specification symbol was called “profile any surface” in former versions of this document.				
<sup>a</sup> See also ISO 1660.				
<sup>b</sup> See also ISO 5458.				



**Table 3 — Additional symbols defined in this document**

Description	Symbol	Clause
Combination specification elements		
Combined zone	$CZ^a$ <sup>c</sup>	<a href="#">8.2.2.1.2</a>
Separate zones	$SZ^a$	<a href="#">8.2.2.1.2</a> , ISO 2692 and ISO 5458
Unequal zone specification elements		
Specified tolerance zone offset	$UZ^a$	<a href="#">8.2.2.1.3</a>
Constraint specification elements		
Unspecified linear tolerance zone offset (offset zone)	OZ	<a href="#">8.2.2.1.4.1</a>
Unspecified angular tolerance zone offset (variable angle)	VA	<a href="#">8.2.2.1.4.2</a>
Associated toleranced feature specification elements		
Minimax (Chebyshev) feature	$\textcircled{C}$	<a href="#">8.2.2.2.2</a>
Least squares (Gaussian) feature	$\textcircled{G}$	<a href="#">8.2.2.2.2</a>
Minimum circumscribed feature	$\textcircled{N}$	<a href="#">8.2.2.2.2</a>
Tangent feature	$\textcircled{T}$	<a href="#">8.2.2.2.2</a>
Maximum inscribed feature	$\textcircled{X}$	<a href="#">8.2.2.2.2</a>
Derived toleranced feature specification elements		
Derived feature	$\textcircled{A}$	Clause 6 and <a href="#">8.2.2.2.3</a>
Projected tolerance zone	$\textcircled{P}$	Clause 12 and <a href="#">8.2.2.2.3</a>
Reference feature association specification elements		
Minimax (Chebyshev) feature without constraint	C	<a href="#">8.2.2.3.1</a>
Minimax (Chebyshev) feature with external material constraint	CE	<a href="#">8.2.2.3.1</a>
Minimax (Chebyshev) feature with internal material constraint	CI	<a href="#">8.2.2.3.1</a>
Least squares (Gaussian) feature without constraint	G	<a href="#">8.2.2.3.1</a>
Least squares (Gaussian) feature with external material constraint	GE	<a href="#">8.2.2.3.1</a>
Least squares (Gaussian) feature with internal material constraint	GI	<a href="#">8.2.2.3.1</a>
Minimum circumscribed feature	N	<a href="#">8.2.2.3.1</a>
Maximum inscribed feature	X	<a href="#">8.2.2.3.1</a>
Parameter specification elements		
Total range of deviations	T	<a href="#">8.2.2.3.2</a>
Peak height	P	<a href="#">8.2.2.3.2</a>
Valley depth	V	<a href="#">8.2.2.3.2</a>
Standard deviation	Q	<a href="#">8.2.2.3.2</a>
For drawing default symbols, see <a href="#">Table 6</a> .		
a See also ISO 1660, ISO 2692 and ISO 5458.		
b The letters, values and characteristic symbols in these symbols are examples.		
c The CZ symbol was called "common zone" in the former version of this document.		


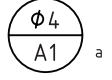

**Table 3 (continued)**

Description	Symbol	Clause
Toleranced feature identifiers		
Between		<a href="#">3.5</a> , <a href="#">7.2</a> , <a href="#">8.2.2.1.1</a> , <a href="#">8.2.2.1.3</a> , <a href="#">8.4.2</a> , <a href="#">9.1.3</a> and <a href="#">9.1.4</a>
United Feature	UF	<a href="#">3.9</a> and <a href="#">8.4.2</a>
Minor diameter	LD	<a href="#">8.4.2</a>
Major diameter	MD	<a href="#">8.4.2</a>
Pitch diameter	PD	<a href="#">8.4.2</a>
All around (profile)		<a href="#">9.1.2</a>
All over (profile)		<a href="#">9.1.2</a>
Tolerance indicator		
Geometrical specification indication without datum section		<a href="#">8.2</a>
Geometrical specification indication with datums section		<a href="#">8.2</a> and ISO 5459
Auxiliary feature indicators		
Any cross-section	ACS	<a href="#">8.4.2</a>
Intersection plane indicator		<a href="#">Clause 13</a>
Orientation plane indicator		<a href="#">Clause 14</a>
Direction feature indicator		<a href="#">Clause 15</a>
Collection plane indicator		<a href="#">Clause 16</a>
Theoretically exact dimension symbol		
Theoretically exact dimension (TED)		10
For drawing default symbols, see <a href="#">Table 6</a> .		
a See also ISO 1660, ISO 2692 and ISO 5458.		
b The letters, values and characteristic symbols in these symbols are examples.		
c The CZ symbol was called "common zone" in the former version of this document.		

**Table 4 — Additional symbols defined in other standards**

Description	Symbol	Reference
Material condition specification element		
Maximum material requirement	Ⓜ	ISO 2692
Least material requirement	Ⓛ	ISO 2692
Reciprocity requirement	Ⓡ	ISO 2692
State specification element		
Free state condition (non-rigid parts)	ⓕ	ISO 10579
a The letters, values and characteristic symbols in these symbols are examples.		

Table 4 (continued)

Description	Symbol	Reference
Datum related symbols		
Datum Feature Indicator		ISO 5459
Datum Target Indicator		ISO 5459
Contacting feature	CF	ISO 5459
Orientation constraint only	>>	ISO 5459
Size tolerance related symbol		
Envelope requirement		ISO 14405-1
<sup>a</sup> The letters, values and characteristic symbols in these symbols are examples.		

## 6 Toleranced features

A geometrical specification applies to a single complete feature unless specifically indicated otherwise. When the toleranced feature is not a single complete feature, see [8.4.2](#), [Clause 9](#) and [Clause 11](#).

When the geometrical specification refers to the integral feature, the geometrical specification indication shall be connected to the toleranced feature by a reference line, see [8.4.1](#), and a leader line terminating in one of the following ways:

- In 2D annotation, on the outline of the feature or an extension of the outline (but clearly separated from the dimension line) [see [Figures 1 a](#)) and 2 a)]. The termination of the leader line is
  - an arrow if it terminates on an outline or an extension line of the feature, or
  - a dot when the leader line terminates within the bounds of the feature [see [Figure 3 a](#))]. When the surface is visible, the dot is filled out; when the surface is hidden the dot is not filled out and the leader line is a dashed line.
  - The arrow may be placed on a reference line using a leader line to point to the surface [see [Figure 3 a](#))].
- In 3D annotation, on the integral feature or an extension of the outline (but clearly separated from the dimension line) [see [Figures 1 b](#)) and 2 b)]. The termination of the leader line is an arrow on an extension line and a dot on the integral feature. When the surface is visible, the dot is filled out; when the surface is hidden the dot is not filled out and the leader line is a dashed line.
- The termination of the leader line may be an arrow placed on a reference line using a leader line to point to the surface [see [Figure 3 b](#))]. The above rules for the dot terminating the leader line also apply in this case.

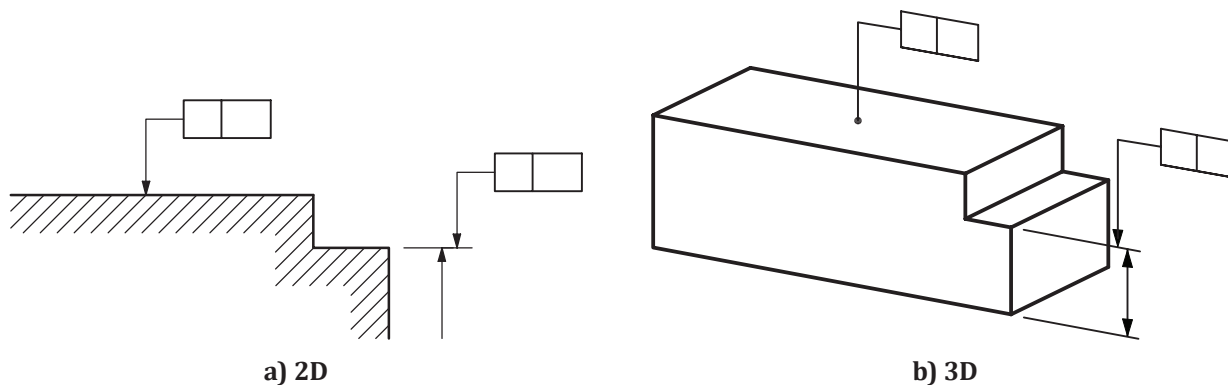


Figure 1 — Indication of integral feature specification

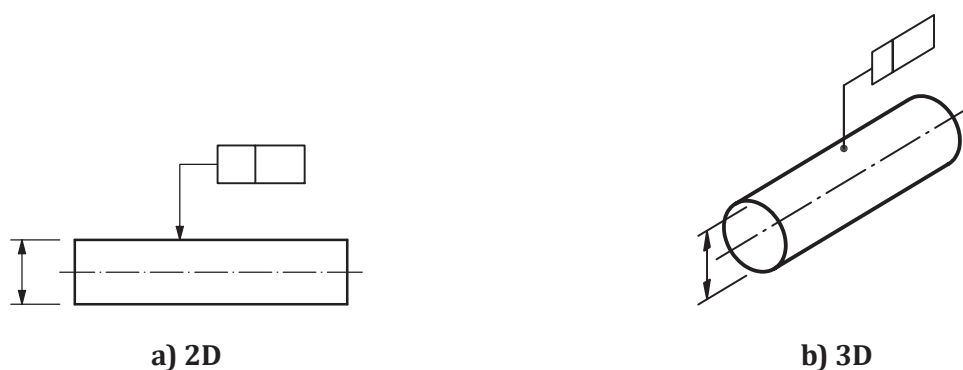


Figure 2 — Indication of integral feature specification

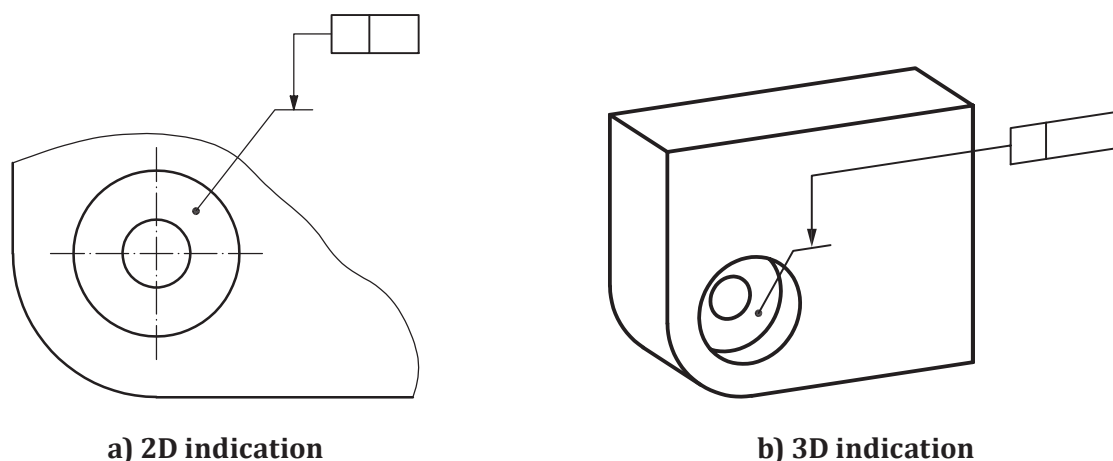


Figure 3 — Connecting the specification to the tolerated feature using a reference line and a leader line

When the geometrical specification refers to a derived feature (a median point, a median line, or a median surface), it shall be indicated either

- by a reference line, see 8.4.1, and a leader line terminated by an arrow on the extension of the dimension line of a feature of size (see the examples in Figures 4, 5, and 6), or

- in the case of a revolute, by a modifier  $\textcircled{A}$  (median feature) placed in the zone, feature and characteristic section of the tolerance indicator. In this case, the leader line does not have to terminate on the dimension line, but can terminate with a dot on the integral feature or an arrow on the outline or an extension line (see [Figure 7](#)).

NOTE The modifier  $\textcircled{A}$  can only be used for revolutes and not for other types of features of size, because in other cases it can be ambiguous which is the other feature making up the feature of size.

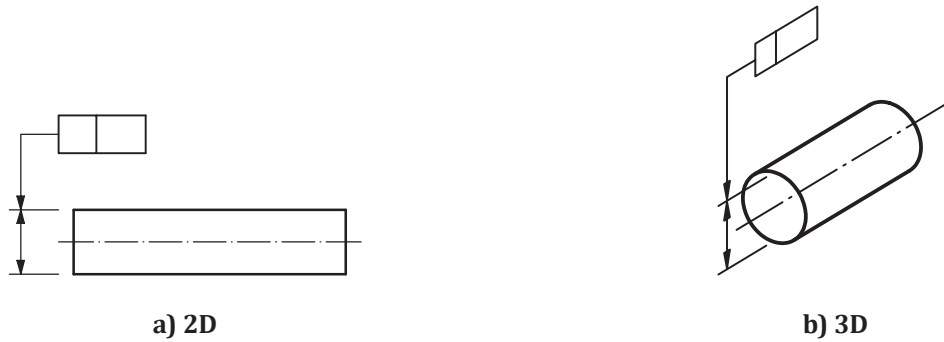


Figure 4 — Indication of derived feature specification

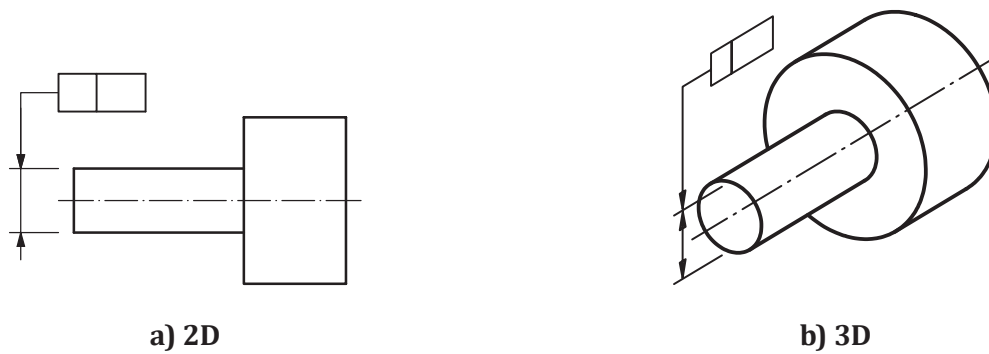


Figure 5 — Indication of derived feature specification

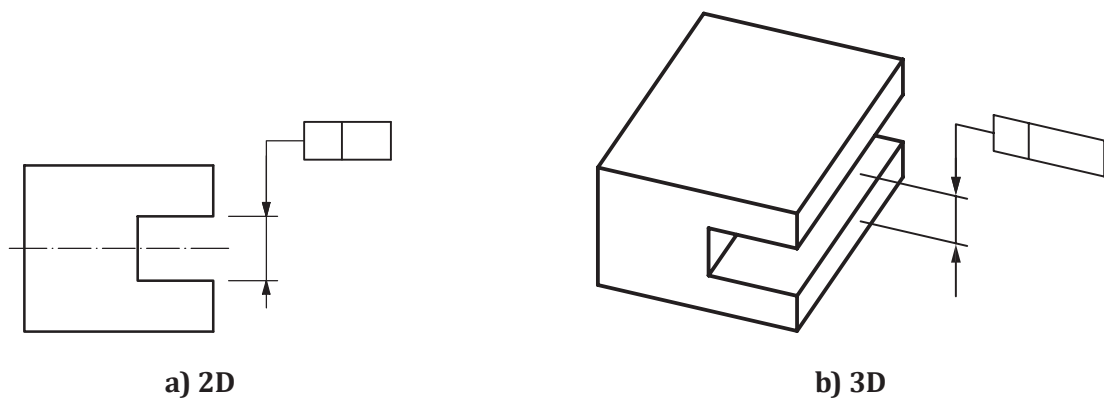


Figure 6 — Indication of derived feature specification

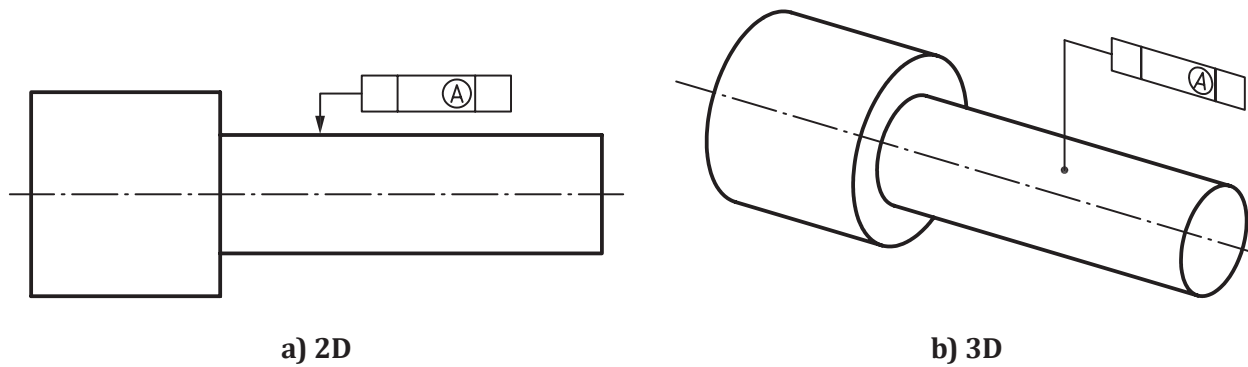


Figure 7 — Indication of median feature specification

If necessary, an intersection plane indicator shall be used to specify that the tolerated feature is a set of lines, see [Figure 122](#), instead of a surface, see [Figure 126](#).

NOTE When the tolerated feature is a derived line, a further indication may be needed to control the orientation of the tolerance zone, see [Figure 114](#).

## 7 Tolerance zones

### 7.1 Tolerance zone defaults

The tolerance zone shall be positioned symmetrically around the reference feature unless otherwise indicated (see [8.2.2.1.3](#)). The tolerance value defines the width of the tolerance zone. The local width of the tolerance zones shall apply normal to the specified geometry (see [Figures 8 and 9](#)) unless otherwise indicated. See [Clause 15](#).

For roundness of revolute surfaces that are neither cylindrical nor spherical, e.g. cones, the direction of the width of the tolerance zones shall always be indicated. See [Clause 15](#).

NOTE The orientation alone of the leader line does not influence the definition of the tolerance zone, except in the case where the orientation of the leader line and therefore the direction of the width of the tolerance zone is indicated by a TED. See [Clause 15](#).

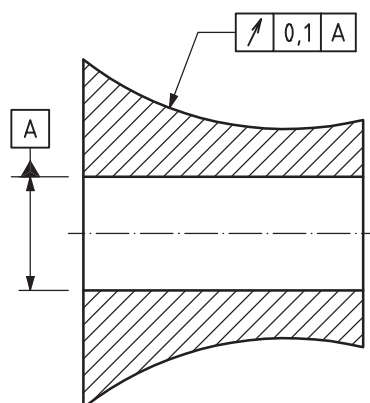
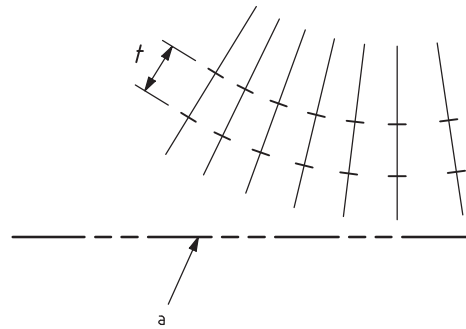


Figure 8 — Drawing indication



a Datum A.

Figure 9 — Interpretation

## 7.2 Tolerance zones of variable width

The tolerance value is constant along the length of the considered feature, unless otherwise indicated by a graphical indication, defining a proportional variation from one value to another, between two specified locations on the considered feature, identified as given in 8.2.2.1.1 and 9.1.4 (see Figure 10). By default, the proportional variation follows the curvilinear distance, i.e. the distance along the curve connecting the two specified locations. See also ISO 1660 for further information.

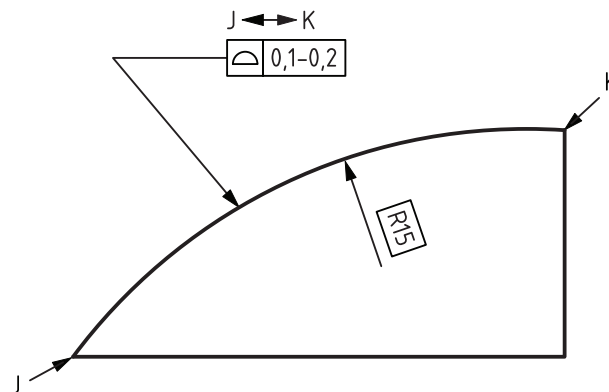


Figure 10 — Drawing indication for variable width specification using the between symbol

## 7.3 Orientation of tolerance zones for derived features

For derived features, in the case of a tolerance zone consisting of two parallel planes limiting a median line or a tolerance zone consisting of a cylinder limiting a centre point of a circle or a sphere, the orientation of the planes or the cylinder shall be controlled by an orientation plane indicator. See Clause 14 and Figures 114 to 117.

NOTE Instead of using orientation plane indicators, similar requirements can often be indicated using the orientation only modifier, see ISO 5459, instead.

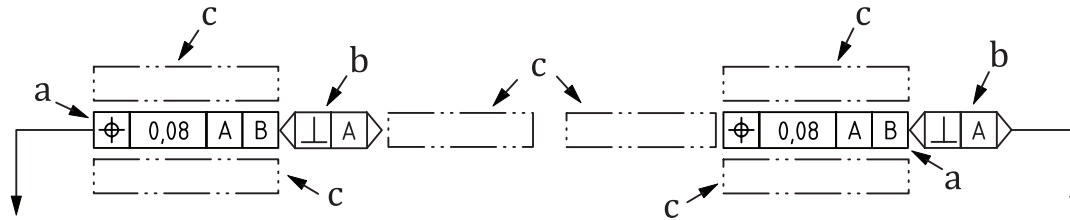
## 7.4 Cylindrical and spherical tolerance zones

The tolerance zone shall be cylindrical or circular if the tolerance value in the second section of the tolerance indicator is preceded by the symbol “ $\varnothing$ ”, see the example in Figure 94, or spherical if it is preceded by the symbol “S $\varnothing$ ”, see Figure 150.

## 8 Geometrical specification indication

### 8.1 General

A geometrical specification indication consists of a tolerance indicator, optional plane and feature indications and optional adjacent indications. See [Figure 11](#).



#### Key

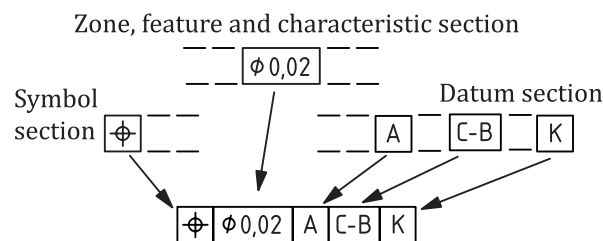
- a tolerance indicator
- b plane and feature indicator
- c adjacent indications

**Figure 11 — Elements of a geometrical specification indication**

The geometrical specification indication shall be connected to the leader line by a reference line. The reference line shall be attached to the mid-point of the left hand end or the right hand end of the tolerance indicator, if there is no optional plane and feature indication. If there are optional plane and feature indication(s), the reference line shall be attached to the mid-point of the left hand end of the tolerance indicator or the mid-point of the right hand end of the last plane and feature indicator. This applies both in 2D and 3D.

### 8.2 Tolerance indicator

The requirements shall be indicated in a rectangular frame which is divided into two or three sections. The third, optional, datum section may consist of one to three compartments. The sections are always arranged from left to right as in [Figure 12](#).



**Figure 12 — Three sections of the tolerance indicator**

NOTE The tolerance indicator was formerly called the tolerance frame.

#### 8.2.1 Symbol section

The symbol section shall contain the symbol for the geometrical characteristic. See [Table 2](#).

#### 8.2.2 Zone, feature and characteristic section

An overview of which specification elements can be used in the zone, feature and characteristic section of the tolerance indicator is shown in [Figure 13](#). [Figure 13](#) also shows the grouping and sequence in which these specification elements shall be indicated.



The specification elements are explained in the following subclauses in the sequence shown in [Figure 13](#). All specification elements are optional except the width element.

Tolerance zone					Toleranced feature				Characteristic		Material condition	State
Shape	Width and extent	Comb.	Specified offset	Con-straint	Filter <sup>a</sup>		Ass. tol. feature	Derived feature	Association <sup>b</sup>	Parameter <sup>c</sup>		
					Type	Indices						
$\phi$	0,02	CZ	UZ+0,2	OZ	G	0,8	Ⓒ	Ⓐ	C CE CI	P	Ⓜ	Ⓕ
S $\phi$	0,02-0,01	SZ	UZ-0,3	VA	S	-250	Ⓔ	Ⓟ	G GE GI	V	Ⓛ	
	0,1/75		UZ+0,1:+0,2	><	etc.	0,8-250	Ⓝ	Ⓟ 25	X	T	Ⓡ	
	0,1/75×75		UZ+0,2:-0,3			500	Ⓣ	Ⓟ 32-7	N	Q		
	0,2/φ4		UZ-0,2:-0,3			-15	Ⓧ					
	0,2/75×30°					500-15						
	0,3/10°×30°					etc.						
1a	1b	2 <sup>d</sup>	3	4 <sup>d</sup>	5a	5b	6	7 <sup>d</sup>	8	9	10 <sup>d</sup>	11
8.2.2.1					8.2.2.2				8.2.2.3		8.2.2.4	8.2.2.5

- a For filters, see [Tables C.1](#) and [C.2](#).
- b For associations, see [Table D.1](#).
- c For parameters, see [Table D.2](#)
- d For this column, it is possible to use more than one of the listed modifiers.

NOTE 1 The list of modifiers may be extended.

NOTE 2 Some of the information about the toleranced feature may be in adjacent indications, see [8.4.4](#).

NOTE 3 The last row in the figure indicates the subclause where the interpretation of the specification elements is defined.

NOTE 4 The associated toleranced feature specification element changes the toleranced feature, see [8.2.2.2.2](#). The characteristic association specification element changes the reference feature from which characteristic parameters are calculated, see [8.2.2.3.1](#).

**Figure 13 — Specification elements in the tolerance zone, feature and characteristic section of the tolerance indicator**

There shall be a space between specification elements from different numbered compartments, except specification elements in compartments 6, 7, 10 and 11 (letters in circles) shall not be preceded by a space.

There shall be no spaces between the specification elements within one numbered compartment or between the specification elements in compartment 1a and 1b and 5a and 5b, respectively.

If required, the filtering of the toleranced feature shall be defined by one or more letters followed immediately by numbers without a space, see [Figures E.9](#) to [E.18](#).

The associated feature that the deviation is calculated from and/or the parameter shall be defined by one or more letters from compartments 8 and 9 not followed by numbers. This is how these specification elements can be distinguished from the filtering specification elements. This indication does not change the toleranced feature, see [Figures 38](#) to [41](#) and [Figures 44](#) to [45](#).

### 8.2.2.1 Tolerance zone specification elements

#### 8.2.2.1.1 Shape, width and extent specification elements

The shape specification element is an optional specification element.

By default:

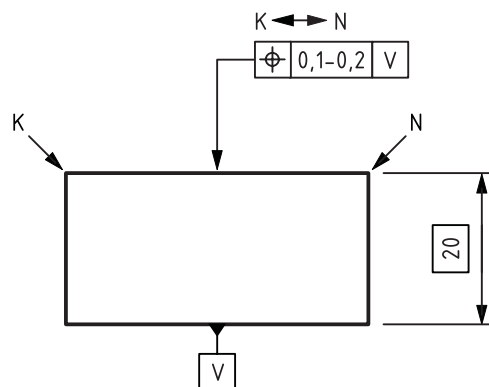
- if the tolerated feature is a surface, then the shape of the tolerance zone is defined as the space between two equidistant surfaces based on the nominal geometry of the tolerated feature, see [17.8](#) for an example.
- if the tolerated feature is an integral line, then the shape of the tolerance zone is defined as the area between two equidistant lines in the intersection plane based on the nominal geometry of the tolerated feature, see [17.6](#) for an example.
- if the tolerated feature is a nominally straight derived line, then the shape of the tolerance zone is defined as the space between two equidistant planes, see [17.10.2](#) for an example.

If the tolerated feature is a line or a point and the tolerance zone is a circle, a cylinder, or a circular tube, the tolerance value shall be preceded by the symbol “ $\varnothing$ ” see [Figures 94](#) and [95](#). If the tolerated feature is a point and the tolerance zone is spherical, the tolerance value shall be preceded by the symbol “ $S\varnothing$ ”, see [Figure 150](#).

The tolerance value is a mandatory specification element. The tolerance value shall be given in the unit used for linear dimensions. The tolerance value gives the width of the tolerance zone, which is by default perpendicular to the tolerated feature.

By default, the tolerance zone has a constant width. If the width of the tolerance zone varies linearly between two values, these two values shall be indicated separated by a “-”, see [Figure 14](#) and [7.2](#).

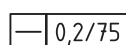
An indication using the between symbol adjacent to the tolerance indicator, see [9.1.4](#), shall be used to identify the two locations where each value applies, see [Figure 14](#).



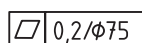
**Figure 14 — Specification of a linearly variable tolerance zone**

If the variation is not linear, it shall be indicated by other means.

By default, the specification applies to the entire tolerated feature. If the specification applies to any restricted portion within the total extent of the feature, the extent of the restricted portion in linear or angular units, or both, (as applicable) shall be added after the tolerance value and separated from it by an oblique stroke. If a tolerance applies to a specific restricted portion within the extents of the feature, the methods in [9.1.3](#) are used. [Figure 15](#) shows a requirement that is limited to line elements. [Figure 16](#) shows a requirement that is limited to circular areas. See also [Clause 11](#).



**Figure 15 — Linear-restricted tolerance zone specification**



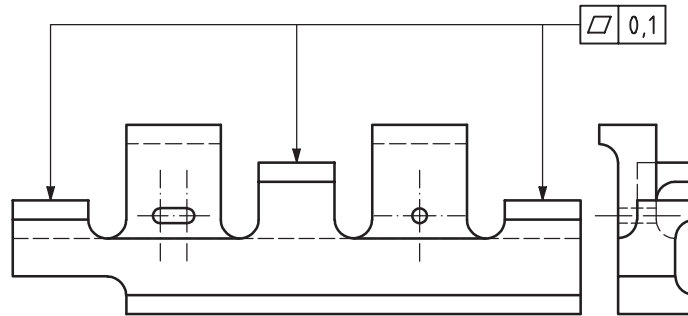
**Figure 16 — Circular area restricted tolerance zone specification**

### 8.2.2.1.2 Combination specification element

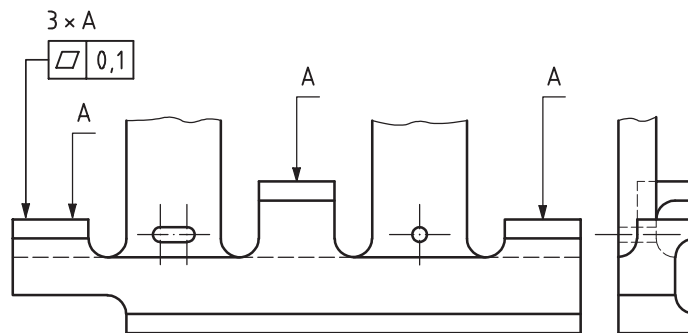
If the specification applies to several features, see [Figures 17](#) to [20](#), an indication shall be given indicating how the specification applies to the features.

By default, the specification requirement for each toleranced feature is independent, due to the independency principle, see ISO 8015.

The indication SZ can optionally be indicated to emphasize the independency of the feature requirements; however it does not change the meaning of the indication in this case, see [Figure 53](#). SZ stands for “Separate Zones”.



**Figure 17 — Specification applying to several features individually**



**Figure 18 — Specification applying to several features individually**

Where one combined tolerance zone is applied to several separate features, or several combined tolerance zones (controlled by the same tolerance indicator) are applied simultaneously to several separate features (not independently), the requirement shall be indicated by the symbol CZ for combined zone, see [Figures 19](#) and [20](#). The indication shall be supplemented by an indication that the specification applies to several features [either using e.g. “3×” in an adjacent indication area (see [8.4](#) and [Figure 18](#)), or using, for example, three leader lines attached to the tolerance indicator (see [Figure 19](#)), but not both].

Where CZ is indicated in tolerance indicator (see [Figures 19](#) and [20](#)), all the related individual tolerance zones shall be constrained in location and in orientation amongst themselves using either explicit theoretically exact dimensions (TED), or implicit TEDs, see [3.7](#) Note 4 to entry.

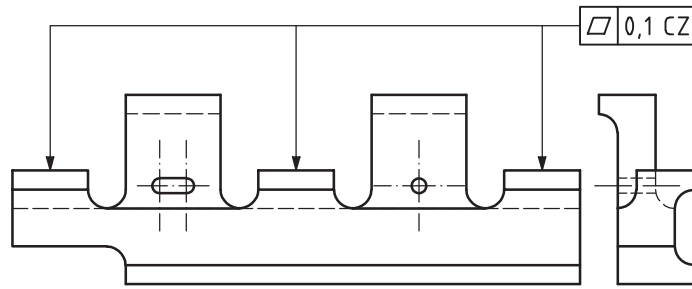
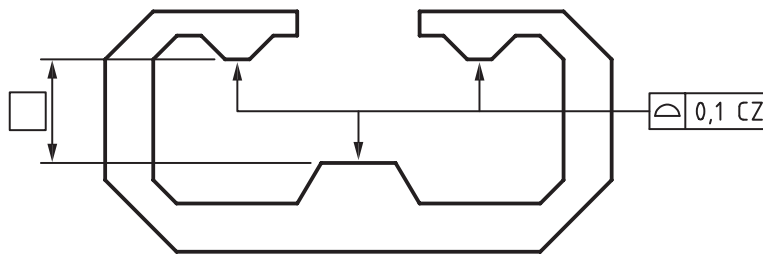


Figure 19 — Combined zone specification applying to several features



NOTE If the tolerated features are flat surfaces, the position symbol can be used with the same meaning.

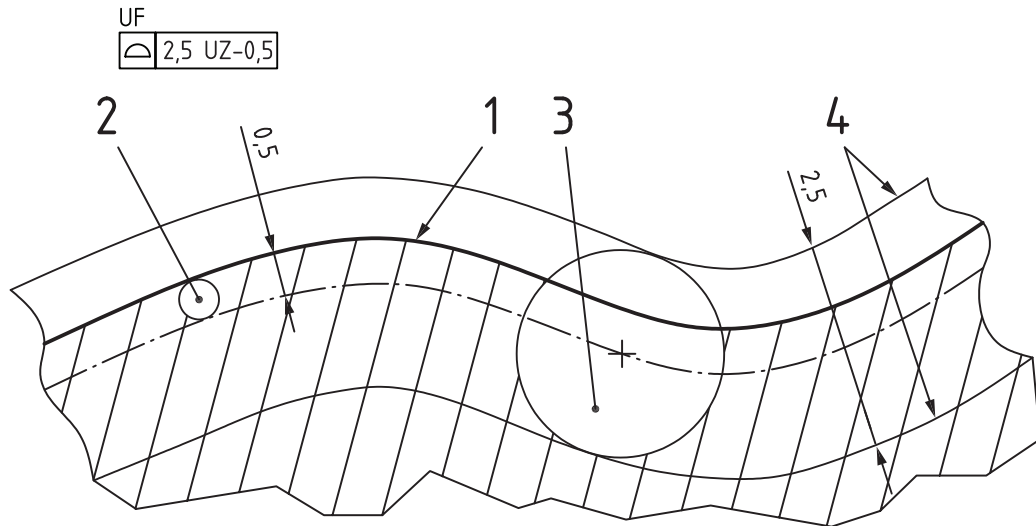
Figure 20 — Combined zone specification applying to several features

The specification element CZ can be used to create a pattern; for more details on patterns, see ISO 5458.

In case of ambiguity, either SZ or CZ shall be indicated. When using “all around” or “all over”, separate rules apply, see [9.1.2](#).

### 8.2.2.1.3 Specified tolerance zone offset specification element

By default, the tolerance zone is symmetrical around the theoretically exact feature (TEF), making it the reference feature. The tolerance zone offset using UZ is an optional specification element. See [Figure 21](#).



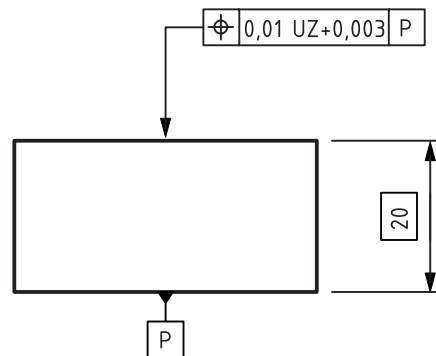
**Key**

- 1 single complex theoretically exact feature (TEF) in this example, the material is below the feature
- 2 one of the infinite number of spheres defining the offset theoretical feature, i.e. the reference feature
- 3 one of the infinite number of spheres defining the tolerance zone along the reference feature
- 4 limits of the tolerance zone

For profile specifications of complex lines or surfaces, the UZ specification element may be used with or without datums.

**Figure 21 — Offset tolerance zone with specified offset**

The extracted surface shall be contained between two equidistant surfaces enveloping spheres of defined diameter equal to the tolerance value, the centres of which are situated on a surface corresponding to the envelope of a sphere in contact with the TEF and whose diameter is equal to the absolute value given after UZ with the direction of the offset indicated by the sign, the “+” sign indicating “out of the material” and the “-” sign “into the material”, see [Figure 22](#). The sign of the offset shall always be indicated. For former practice, see [A.3.9](#).



**NOTE** The UZ specification element in combination with the position symbol can only be used for planar features.

**Figure 22 — Offset tolerance zone specification**

If the offset of the tolerance zone varies linearly between two values, these two values shall be indicated separated by a colon “:”, see [Figure 13](#). In this case, one of the offset values can be a zero and is then indicated without a sign. An indication using the between symbol adjacent to the tolerance indicator, see [9.1.4](#), similar to the one used in [Figure 14](#) shall be used to identify the ends of the tolerance zone where each offset value applies.

If the offset variation is not linear, it shall be specified, e.g. in the CAD model.

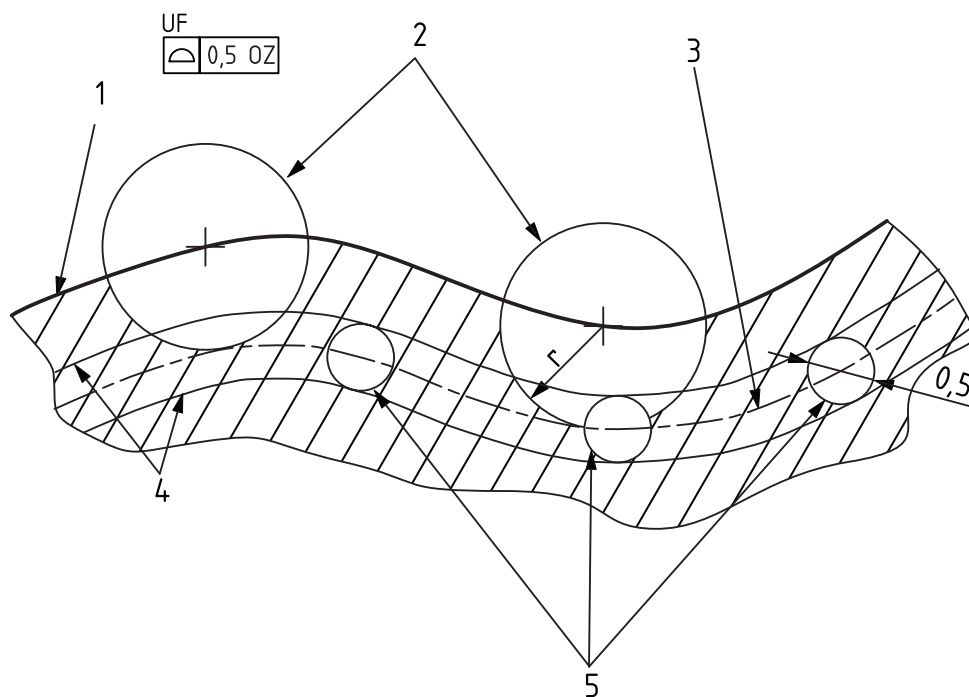
The UZ specification element can only be used for integral features.

### 8.2.2.1.4 Constraint specification elements

#### 8.2.2.1.4.1 Unspecified linear tolerance zone offset specification element

If the tolerance zone is allowed to be offset from being symmetric around the TEF by a constant but unspecified amount, the symbol OZ shall be indicated.

The nominal size of the TEF may not be defined by a TED for circles, cylinders, spheres and tori, e.g. in the case where there is only a  $\pm$  tolerance indicated for the size. In this case, the OZ specification element shall always be indicated for line profile specifications and surface profile specifications to make it explicit that the size of the TEF is not fixed.



#### Key

- 1 single complex theoretically exact feature (TEF)
- 2 two of the infinite number of spheres or circles defining the offset theoretical feature, i.e. the reference feature
- 3 reference feature, equidistant from the TEF
- 4 limits of the tolerance zone
- 5 three of the infinite number of spheres or circles defining the tolerance zone along the reference feature
- r constant, but unspecified offset

This figure shows how the shape of the offset tolerance zone is defined from the TEF. For a form tolerance, i.e. a tolerance without reference to datums, the TEF is unconstrained, i.e. the tolerance zone, when combined with an offset value, may adopt any location or orientation when attempting to fit to the toleranced feature (see 4.8). TEDs and reference to one or more datums in the tolerance indicator can be used to constrain the TEF together with the zone.

**Figure 23 — Offset tolerance zone with unspecified offset**

NOTE 1 Because there are no bounds on the offset, a specification with the OZ modifier is usually combined with a specification using a larger tolerance without the OZ modifier. When both specifications are satisfied, this combination controls the shape of the tolerance feature within the larger, fixed tolerance zone.

NOTE 2 For flat surfaces and straight lines, it is often possible to use, for example, parallelism instead of position to achieve the same effect as 0Z.

#### 8.2.2.1.4.2 Unspecified angular tolerance zone offset specification element

The VA modifier shall be indicated in the zone, feature and characteristic section of the tolerance indicator when the tolerance zone is defined from a TEF, which is an angular feature of size, having its size considered variable (unspecified), see Figure 24. See also example in ISO 3040.

The nominal angular size of the TEF may not be defined by a TED for cones, e.g. in the case where there is only a  $\pm$  tolerance indicated for the angular size. In this case, the VA specification element shall always be indicated for line profile specifications and surface profile specifications to make it explicit that the angular size of the TEF is not fixed.

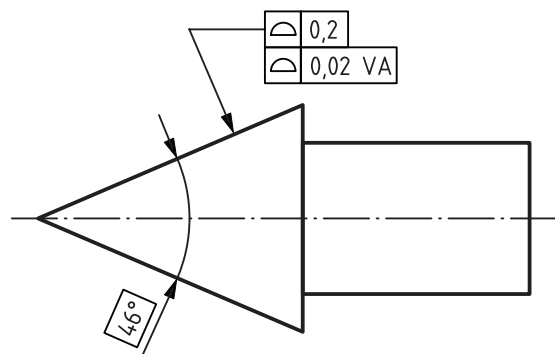


Figure 24 — Variable angle, VA, modifier

NOTE Because there are no bounds on the angular offset, a specification with the VA modifier is usually combined with another specification (angular dimensional specification or geometrical specification without VA modifier), see example in Figure 24.

#### 8.2.2.1.4.3 Orientation only specification element

The orientation only symbol  $\><$  shall be indicated in the zone, feature and characteristic section of the tolerance indicator when the tolerance zone translation is unconstrained, i.e. only rotational degrees of freedom for the tolerance zone are constrained in a specification that would otherwise have its translational degrees of freedom constrained by datums. See also ISO 5459.

NOTE 1 For flat surfaces and straight lines, it is often possible to use, for example, parallelism instead of position to achieve the same effect as orientation only.

NOTE 2 Orientation only allows the tolerance zone to translate untransformed, whereas the tolerance zone is transformed when using 0Z (inside radii becomes smaller and outside radii becomes bigger). This difference is significant for non-straight and non-flat surfaces and for features of size. In Figure 23, if orientation only had been used instead of 0Z, key 3 would not have been transformed, but would have had the same shape as key 1. For single flat surfaces and single straight lines, the effect of 0Z and orientation only is the same.

### 8.2.2.2 Toleranced feature specification element

#### 8.2.2.2.1 Filter specification elements

All the terms related to filtration are defined in ISO 16610-1:2015. The specific filters are defined in the other parts of ISO 16610.

Currently, there is no default filtering defined in the GPS standards. Consequently, the filtering is undefined if it is not explicitly given using these specification elements or other means, see also [C.3](#). This adds an ambiguity of specification, see ISO 17450-2.

NOTE See [A.3.7](#) for former filtering practice.

The filter specification is an optional specification element. The specified filtering of the tolerated feature shall be indicated by a combination of two specification elements. One indicates the type of filter specified, the other indicates the nesting index or indices for the filter.

The symbols for the standardized filters are given in [Table C.1](#). For details on the effect of filters and examples of filter indications, see [Annex E](#).

The nesting indices and their meaning for each filter type are given in [Table C.2](#). For a long-wave pass filter the index shall be followed by a “-”. For a short-wave pass filter the index shall be preceded by a “-”. For a band pass filter using the same filter type for both sides, the long-wave pass filter index shall be given first and the short-wave pass filter index shall be given second. The indices shall be separated by a “-”.

For Fourier filters only, indicated by the specification element F (Fourier), a single value shall be indicated when the specification applies to a single harmonic (wavelength or UPR number). If the specification applies to a filtered feature containing a range of harmonics, the indication shall follow the rules given above.

For band pass filters using different filter types, the long-wave pass filter shall be indicated before the short-wave pass filter.

In the specification operator for band pass filters, the long-wave pass filter shall be applied before the short-wave pass filter.

Short-wave pass filters and band pass filters shall only be used for form specifications, i.e. specifications that do not reference datums, because they remove the location and orientation attributes from the tolerated feature.

For open features, e.g. straight lines, planes and cylinders in the axial direction, the nesting index shall be indicated in mm. For closed features, e.g. cylinders in the circumferential direction, tori and spheres, the nesting index shall be indicated in UPR (undulations per revolution). The units shall not be indicated.

If two different filters shall be used in the two directions for a feature that is open in both directions, e.g. a plane, an intersection plane indicator shall be used to indicate the direction in which the first indicated filter shall be applied. “x” shall be used to separate the two filter indications. The second indicated filter shall be applied in the direction perpendicular to the first filter direction.

For a feature that is open in one direction and closed in the other direction, e.g. a cylinder, the filter for the open direction shall be indicated before the filter for the closed direction. “x” shall be used to separate the two filter indications.

If both filters are of the same type, regardless of whether the two directions are both open (e.g. a plane), both closed (e.g. a sphere) or one of each (e.g. a cylinder), the filter type shall be indicated only once.

When the tolerated feature is a derived feature or an associated feature, the filtration shall be applied on the integral feature before the derivation or association operation.

See [E.2](#) for examples of specifications using filters.

#### 8.2.2.2.2 Associated tolerated feature specification element

By default, the specification applies to the indicated extracted integral or derived feature itself. The associated tolerated feature specification element is an optional specification element. It shall be used to indicate that the specification does not apply to the indicated feature itself, but to a feature associated with it. If a filter is indicated, the association shall be to the filtered feature.



The associated toleranced feature specification element shall only be used for specifications that reference datums, i.e. orientation and location specifications.

If the associated toleranced feature specification element is used together with a filter specification element, the association shall be to the filtered feature as the non-ideal feature.

When the toleranced feature is a derived feature, the associated feature shall be the indirectly associated feature, see ISO 22432.

The extent of the associated toleranced feature shall be equal to the extent of the feature to which it is associated.

The associated toleranced feature specification element shall not be used together with a reference feature association specification element, see 8.2.2.3.1, a parameter specification element, see 8.2.2.3.2, or a material condition specification element, see ISO 2692.

The following associated toleranced feature specification elements are available.

Ⓢ shall be used to indicate that the toleranced feature is the associated minimax (Chebyshev) feature without material constraint. This specification element can be used for features that are nominally straight lines, planes, circles, cylinders, cones and tori.

Figure 25 shows an example of a position specification that applies to the associated minimax (Chebyshev) feature. See also Figure 26.

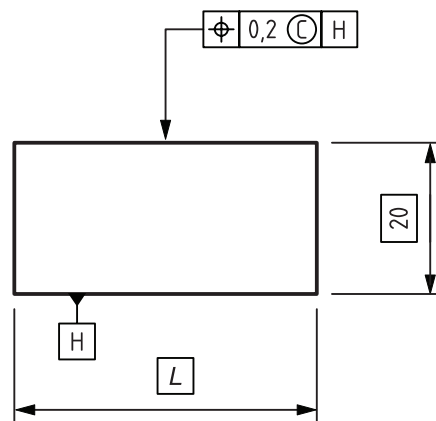
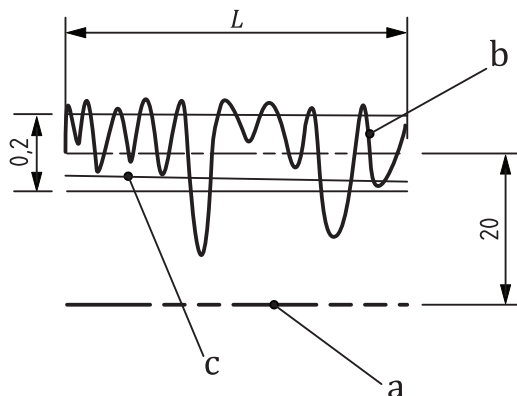


Figure 25 — Minimax (Chebyshev) associated toleranced feature — Drawing indication



**Key**

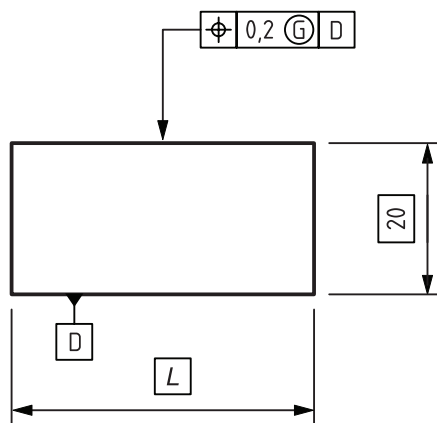
- a datum H
- b real feature or filtered feature
- c minimax (Chebyshev) feature (toleranced feature)

NOTE The tolerated feature is a surface, but for ease of illustration it is shown as a line.

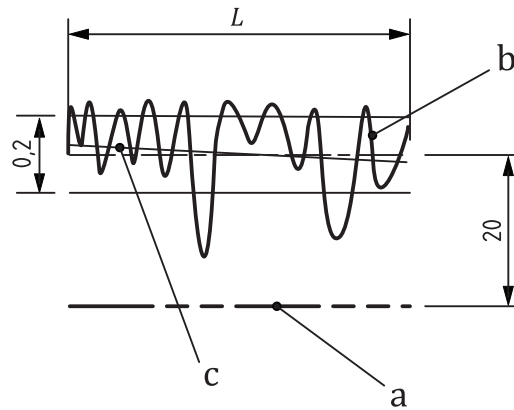
**Figure 26 — Minimax (Chebyshev) associated tolerated feature — Interpretation**

Ⓞ shall be used to indicate that the tolerated feature is the associated least squares (Gaussian) feature without material constraint. This specification element can be used for features that are nominally straight lines, planes, circles and cylinders, cones and tori.

Figure 27 shows an example of a position specification that applies to the associated least squares (Gaussian) feature. See also Figure 28.



**Figure 27 — Least squares (Gaussian) associated tolerated feature — Drawing indication**



**Key**

- a datum D
- b real feature or filtered feature
- c least squares (Gaussian) associated feature (toleranced feature)

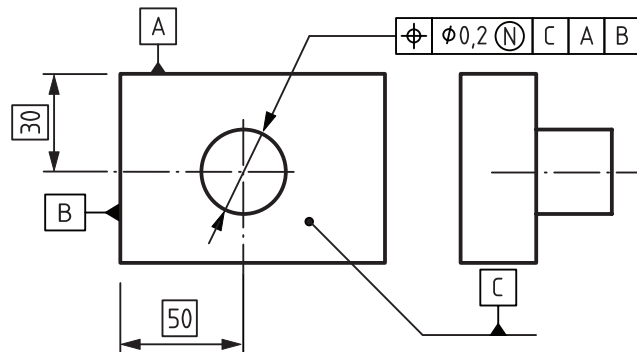
NOTE The tolerated feature is a surface, but for ease of illustration it is shown as a line.

**Figure 28 — Least squares (Gaussian) associated tolerated feature — Interpretation**

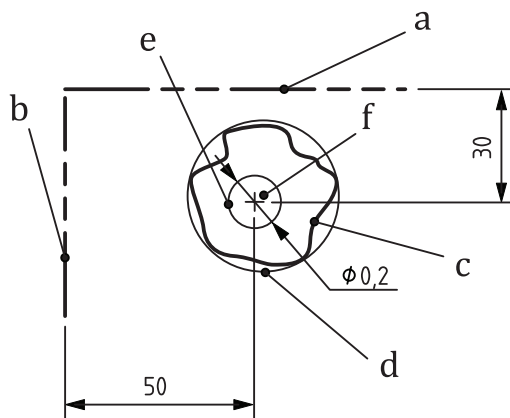
Ⓝ shall be used to indicate that the tolerated feature is the associated minimum circumscribed feature or its derived feature. The minimum circumscribed feature association minimizes the size of the associated feature with the constraint that the associated feature circumscribes the non-ideal feature. This specification element can only be used for features of linear size.

Figure 29 shows an example of a position specification that applies to the associated minimum circumscribed feature. See also Figure 30.

NOTE Although the Ⓝ specification element is usually used for external features, e.g. shafts as in Figure 29, it can also be used for internal features, e.g. holes.



**Figure 29 — Minimum circumscribed associated tolerated feature — Drawing indication**



**Key**

- a datum A
- b datum B
- c real feature or filtered feature
- d minimum circumscribed feature
- e tolerance zone
- f tolerated feature (centreline for d)

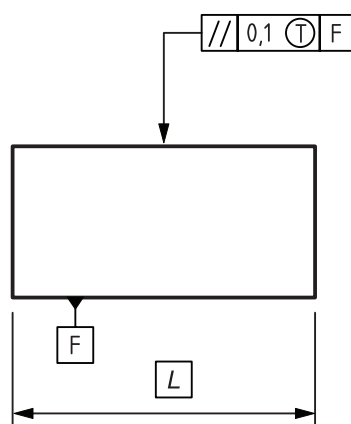
NOTE The tolerated feature is a straight line (the centre line of the associated feature), but for ease of illustration it is shown as a point.

**Figure 30 — Minimum circumscribed associated tolerated feature — Interpretation**

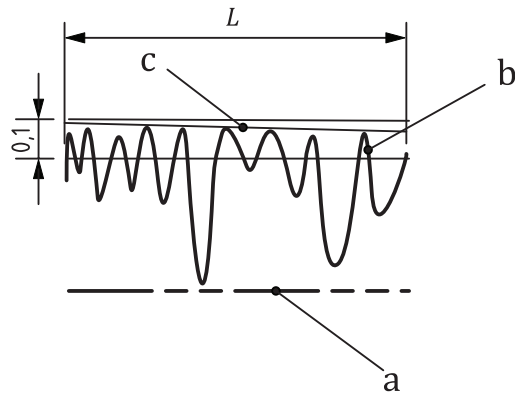
Ⓢ shall be used to indicate that the tolerated feature is the associated tangent feature based on the  $L_2$  norm with the constraint that the tangent feature is outside the material of the non-ideal feature. This specification element can only be used for nominally straight lines and plane features. The tolerated feature is the tangent straight line or plane, as applicable, of the indicated feature.

NOTE The  $L_2$  norm with the constraint that the tangent feature is outside the material is the association criterion for datums, see ISO 5459.

Figure 31 shows an example of a parallelism specification that applies to the associated tangent feature. See also Figure 32.



**Figure 31 — Tangent associated tolerated feature — Drawing indication**



**Key**

- a datum F
- b real feature or filtered feature
- c tangent feature (toleranced feature)

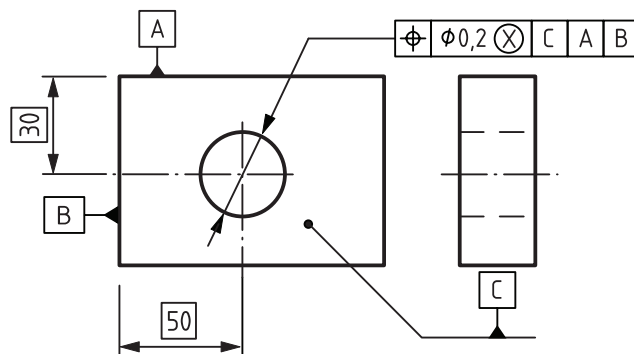
NOTE The toleranced feature is a surface, but for ease of illustration it is shown as a line.

**Figure 32 — Tangent associated toleranced feature — Interpretation**

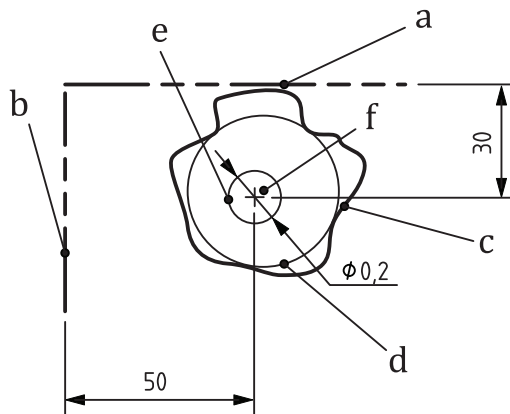
⊗ shall be used to indicate that the toleranced feature is the associated maximum inscribed feature or its derived feature. The maximum inscribed feature association maximizes the size of the associated feature with the constraint that the associated feature is inscribed within the non-ideal feature. This specification element can only be used for features of linear size.

NOTE Although the ⊗ specification element is usually used for internal features, e.g. holes as in [Figure 33](#), it can also be used for external features, e.g. shafts.

[Figure 33](#) shows an example of a position specification that applies to the associated maximum inscribed feature. See also [Figure 34](#).



**Figure 33 — Maximum inscribed associated toleranced feature — Drawing indication**



**Key**

- a datum A
- b datum B
- c real feature or filtered feature
- d maximum inscribed feature
- e tolerance zone
- f toleranced feature (centreline for d)

NOTE The toleranced feature is a straight line (the centre line of the associated feature), but for ease of illustration it is shown as a point.

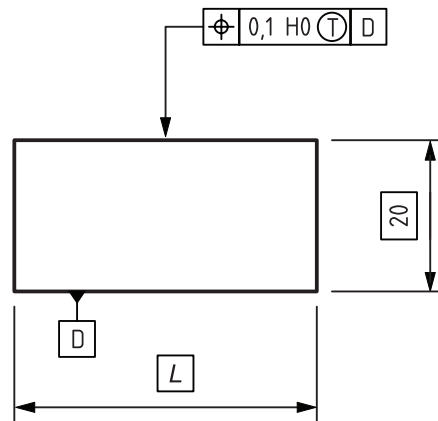
**Figure 34 — Maximum inscribed associated toleranced feature — Interpretation**

A summary of which associated toleranced features can be applied to which types of features is shown in [Table 5](#).

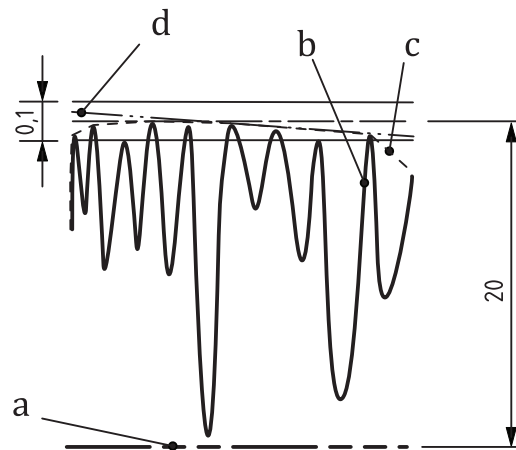
**Table 5 — Summary of applicable associated toleranced features by type of feature**

Type of feature	Ⓒ	Ⓔ	Ⓓ	Ⓙ	ⓧ
Straight line	Yes	Yes		Yes	
Plane	Yes	Yes		Yes	
Circle	Yes	Yes	Yes		Yes
Cylinder	Yes	Yes	Yes		Yes
Cone	Yes	Yes			
Torus	Yes	Yes			
Feature of size: 2 parallel planes	Yes	Yes	Yes	Yes	Yes

The associated toleranced feature specification element can be combined with filter specification elements. [Figure 35](#) shows an example where the  $\text{Ⓙ}$  specification element is combined with the H0 convex hull specification element, indicating that it is the  $L_2$  norm tangent of the convex hull that is the toleranced feature. This toleranced feature is defined the same way a datum based on a plane datum feature is defined, see ISO 5459, thus allowing a specification to control the orientation and location of a datum. See [Figure 36](#).



**Figure 35 — Tangent tolerated feature associated to the convex hull filtered feature — Drawing indication**



**Key**

- a datum D
- b real feature
- c convex hull filtered feature
- d tangent feature to the convex hull filtered feature (toleranced feature)

NOTE The toleranced feature is a surface, but for ease of illustration it is shown as a line.

**Figure 36 — Tangent tolerated feature associated to the convex hull filtered feature — Interpretation**

**8.2.2.2.3 Derived tolerated feature specification element**

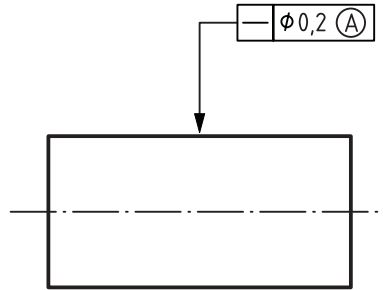
By default, the specification applies to the indicated feature itself, except as given in [Clause 6](#). The derived tolerated feature specification element is an optional specification element. It is used to indicate that the specification does not apply to the integral feature itself, but to a feature derived from it.

The following derived tolerated feature specification elements are available.

- $\textcircled{A}$  is used to indicate that the toleranced feature is the derived feature. Therefore, this specification element can only be used for features of size. Because the indication would be ambiguous, if the feature of size is made up of two features, e.g. two parallel planes, this specification can only be used for revolutes. The derived feature is the median line, if the indicated feature is a cylinder, or the median point, if the indicated feature is a circle or a sphere.

- $\textcircled{P}$  is used to indicate that the tolerance zone applies to an extended feature (projected toleranced feature), see [Clause 12](#).

[Figure 37](#) shows an example of a straightness specification that applies to the derived feature, i.e. the median line of the cylinder.



**Figure 37 — Specification applying to the median feature**

### 8.2.2.3 Characteristic specification elements

#### 8.2.2.3.1 Reference feature association specification element

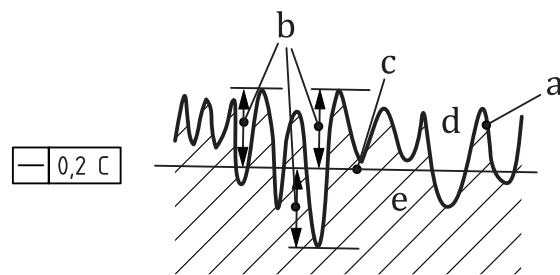
By default, the reference feature association is the minimax (Chebyshev) association without constraints. The reference feature association specification element is an optional specification element. It can be used for form specifications, i.e. specifications that do not reference datums, and other specifications that have at least one unconstrained non-redundant degree of freedom.

The following specification elements are available.

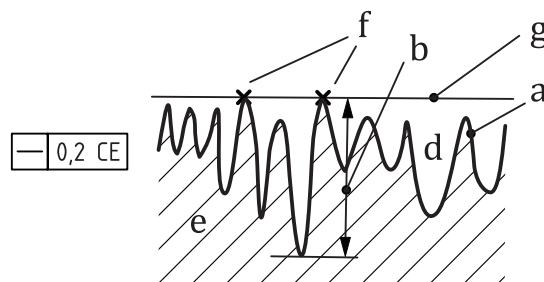
- $\textcircled{c}$  shall be used to indicate the minimax (Chebyshev) association. It minimizes the distance from the furthest point on the toleranced feature to the reference feature, see [Figure 38 a](#)).
- $\textcircled{CE}$  shall be used to indicate the minimax (Chebyshev) association with the constraint external to the material. It minimizes the distance from the furthest point on the toleranced feature to the reference feature while maintaining the reference feature external to the material, see [Figure 38 b](#)).
- $\textcircled{CI}$  shall be used to indicate the minimax (Chebyshev) association with the constraint internal to the material. It minimizes the distance from the furthest point on the toleranced feature to the reference feature while maintaining the reference feature internal to the material, see [Figure 38 c](#)).

**NOTE 1** The minimax (Chebyshev) association without constraint, the minimax (Chebyshev) association with the constraint external to the material and the minimax (Chebyshev) association with the constraint internal to the material (keys c, g and h in [Figure 38](#)) are all by definition parallel.

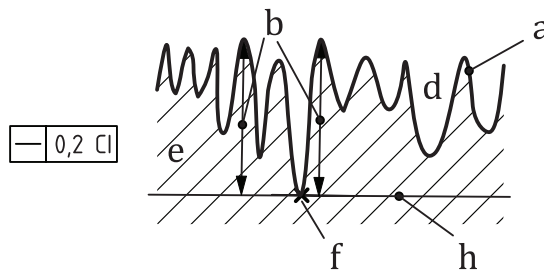




**a) Minimax (Chebyshev) association without additional constraints**



**b) Minimax (Chebyshev) association with the constraint external to the material**



**c) Minimax (Chebyshev) association with the constraint internal to the material**

- a Toleranced feature.
- b Minimized maximum distances.
- c Minimax (Chebyshev) associated straight line without additional constraints – the reference feature with modifier C.
- d Outside the material.
- e Inside the material.
- f Point of contact between the associated feature and the tolerated feature.
- g Minimax (Chebyshev) associated straight line with the constraint external to the material – the reference feature with modifier CE.
- h Minimax (Chebyshev) associated straight line with the constraint internal to the material – the reference feature with modifier CI.

NOTE The tolerance indicators shown in this figure do not show a parameter specification element, see [8.2.2.3.2](#), so the characteristic specified is the total range of deviations, which is the default parameter.

**Figure 38 — Minimax (Chebyshev) associations**

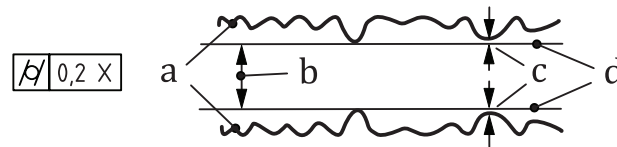
— G shall be used to indicate the least squares (Gaussian) association. It minimizes the square of the local deviations of the tolerated feature to the reference feature.

- $G_E$  shall be used to indicate the least squares (Gaussian) association with the constraint external to the material. It minimizes the square of the local deviations of the tolerated feature to the reference feature while maintaining the reference feature external to the material.
- $G_I$  shall be used to indicate the least squares (Gaussian) association with the constraint internal to the material. It minimizes the square of the local deviations of the tolerated feature to the reference feature while maintaining the reference feature internal to the material.

NOTE 2 The least squares (Gaussian) associations are similar to the minimax (Chebyshev) associations shown in [Figure 38](#), except what is minimized is not the maximum distance to the associated feature but the square root of the sum of the squares of the local deviations between the tolerated feature and the reference feature.

NOTE 3 The least squares (Gaussian) association without constraint, the least squares (Gaussian) association with the constraint external to the material and the least squares (Gaussian) association with the constraint internal to the material (equivalent to keys c, g and h in [Figure 38](#)) are not parallel by definition.

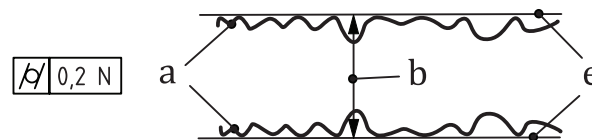
- $X$  shall be used to indicate the maximum inscribed association. It is only available for tolerated features of linear size. It maximizes the size of the reference feature while maintaining it entirely inside the tolerated feature. See [Figure 39](#).



- a Toleranced feature of size.
- b Size of the associated feature (maximized).
- c Equalized distance, in case of unstable association.
- d Maximum inscribed associated feature of size.

**Figure 39 — Maximum inscribed association**

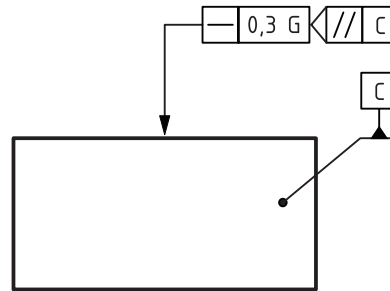
- $N$  shall be used to indicate the minimum circumscribed association. It is only available for tolerated features of linear size. It minimizes the size of the reference feature while maintaining it entirely outside the tolerated feature. See [Figure 40](#).



- a Toleranced feature of size.
- b Size of the associated feature (minimized).
- e Minimum circumscribed associated feature of size.

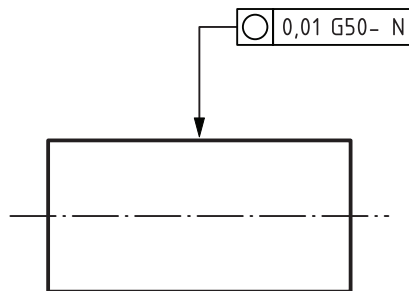
**Figure 40 — Minimum circumscribed association**

[Figure 41](#) shows an example of a straightness specification that applies relative to the least squares (Gaussian) reference feature. The intersection plane indicator indicates that the direction of the tolerated lines is parallel to datum C.



**Figure 41 — Specification using the least squares (Gaussian) reference feature specification element**

Figure 42 shows an example of a roundness specification that applies relative to the minimum circumscribed reference feature after the application of a Gaussian long-wave pass filter with a cutoff value of 50 UPR. The filter type specification element shall always be followed by the nesting index value and the reference feature specification element consists of letters only. When they both apply in the same specification, the filter type specification element shall always precede the reference feature specification element.



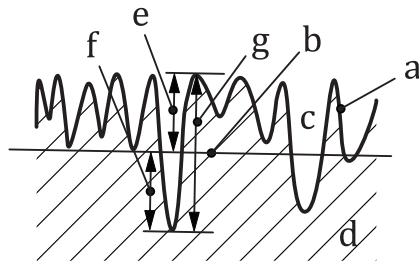
**Figure 42 — Specification using a filter specification element and the minimum circumscribed reference feature specification element**

### 8.2.2.3.2 Parameter specification element

The default parameter that applies when no specification element is indicated is the total range of deviations, i.e. the distance from the lowest valley on the tolerated feature to the reference feature plus the distance from the highest peak of the tolerated feature to the reference feature. The parameter specification element is an optional specification element. It can be used for form specifications, i.e. specifications that do not reference datums, and other specifications that have at least one unconstrained non-redundant degree of freedom.

The following parameter specification elements are available.

- T may be used to indicate the total range of deviations, i.e. the default parameter, see [Figure 43](#).
- P shall be used to indicate the peak height, i.e. the distance from the highest peak of the tolerated feature to the reference feature. The peak height is only defined relative to the minimax (Chebyshev) association and the least squares (Gaussian) association, i.e. the association specification elements C and G, see [Figure 43](#).
- V shall be used to indicate the valley depth, i.e. the distance from the lowest valley of the tolerated feature to the reference feature. The valley depth is only defined relative to the minimax (Chebyshev) association and the least squares (Gaussian) association, i.e. the association specification elements C and G, see [Figure 43](#).



- a Toleranced feature.
- b Minimax (Chebyshev) or least squares (Gaussian) associated straight line without additional constraints (reference feature).
- c Outside the material.
- d Inside the material.
- e Peak height (P) parameter.
- f Valley depth (V) parameter.
- g Total range (T) parameter,  $T = P + V$ .

**Figure 43 — Parameters**

- $Q$  shall be used to indicate the square root of the sum of the squares of the residuals or standard deviation of the tolerated feature relative to the reference feature.

$$Q = \sqrt{\frac{1}{l} \int_0^l Z^2(x) dx} \text{ for linear features,}$$

or

$$Q = \sqrt{\frac{1}{a} \int_0^a Z^2(x) dx} \text{ for areal features}$$

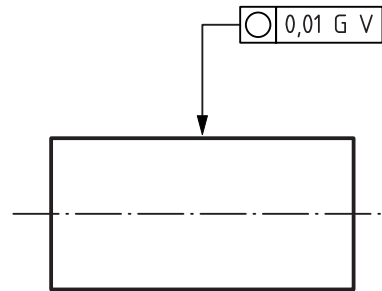
where

- $Q$  is the  $Q$  parameter;
- $l$  is the length of the tolerated feature;
- $a$  is the area of the tolerated feature;
- $Z(x)$  is the local deviation function for the tolerated feature;
- $x$  is the position along the tolerated feature.

NOTE 1 The origin of  $Z(x)$  is the reference feature, either the default reference feature [minimax (Chebyshev) without constraint] or the reference feature specified according to [8.2.2.3.1](#).

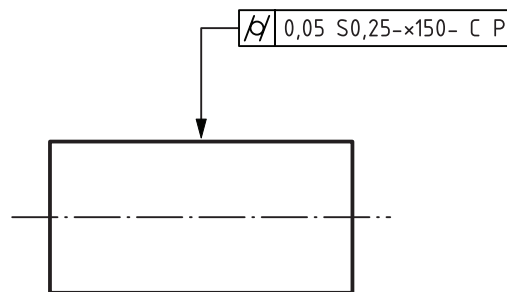
NOTE 2 The  $T$  specification element is the only one that conforms to the concept of a tolerance zone.

[Figure 44](#) shows an example of a roundness specification that applies to the valley depth relative to the least squares (Gaussian) reference circle.



**Figure 44 — Specification using the least squares (Gaussian) reference feature specification element and the valley depth characteristic specification element**

Figure 45 shows an example of a cylindricity specification that applies to the peak height relative to the minimax (Chebyshev) reference cylinder after the application of a spline long-wave pass filter with cutoff values of 0,25 mm in the axial direction and 150 UPR in the circumferential direction.



**Figure 45 — Specification of a filter specification element, a reference feature specification element and a characteristic specification element**

#### 8.2.2.4 Material condition specification element

The material requirement specification elements,  $\textcircled{M}$ ,  $\textcircled{L}$  and  $\textcircled{R}$ , are optional specification elements, see ISO 2692.

#### 8.2.2.5 State specification element

The state specification element,  $\textcircled{F}$ , is an optional specification element, see ISO 10579.

#### 8.2.3 Datum section

For datums and indications in the datum section, see ISO 5459.

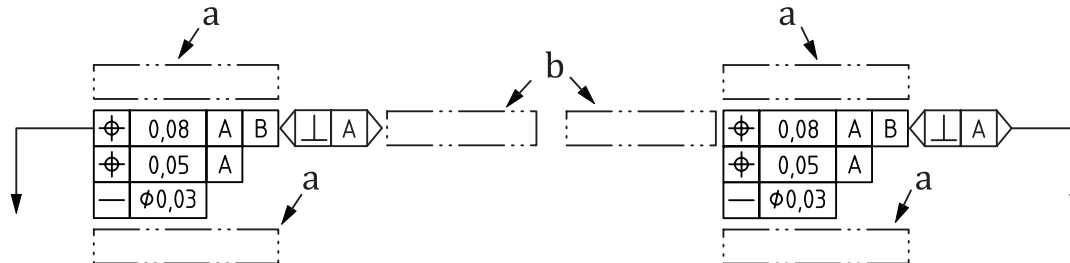
### 8.3 Plane and feature indicators

Intersection plane indicators (Clause 13), orientation plane indicators (Clause 14), direction feature indicators (Clause 15) and collection plane indicators (Clause 16) can be indicated to the right of the tolerance indicator. If several of these are indicated, the intersection plane indicator shall be indicated nearest the tolerance indicator, followed by the orientation plane indicator or direction feature indicator (these two shall not be indicated together), and finally the collection plane indicator. There shall be no space between the tolerance indicator and the plane and feature indicator(s). When any of these indicators are indicated, the reference line can either be attached to the left hand end of the tolerance indicator or the right hand end of the last of the optional indicators.

## 8.4 Indications adjacent to the tolerance indicator

### 8.4.1 General

There are three areas adjacent to the tolerance indicator where supplementary indications can be indicated, see [Figure 46](#).



- a Upper/lower adjacent indication area.
- b Inline adjacent indication area.

**NOTE** While indications in the upper and lower adjacent indication areas mean the same, it is preferable to use the upper adjacent indication area, if practical.

**Figure 46 — Adjacent indication areas**

Indications that apply to all the tolerance indicators attached to the leader line as well as any dimensional specifications shall be indicated in the upper or lower adjacent indication area. The meaning of indications in the upper and lower adjacent indication areas is identical. Only one of these adjacent areas shall be used.

Indications that only apply to one tolerance indicator shall be indicated in an inline adjacent indication area for that tolerance indicator. [Figure 46](#) shows the placement of inline adjacent indication areas, depending on which end of the tolerance indication the reference line is attached to.

When there is only one tolerance indicator, indications in the upper/lower adjacent indication areas and in the inline adjacent indication area mean the same. In this case, only one adjacent indication area shall be used and it is preferable to use the upper adjacent indication area, if practical.

Indications in the upper/lower adjacent indication areas shall be left aligned. Indications in the inline adjacent indication area shall be left aligned if it is to the right of the tolerance indicator and right aligned if it is to the left of the tolerance indicator.

### 8.4.2 Toleranced feature identifiers

If the toleranced feature is not the entire single feature indicated by the leader line and arrow attached to the tolerance indicator, an indication shall be given indicating the toleranced feature.

- ACS, if the toleranced feature is an intersection line or an intersection point defined as the intersection between an extracted integral feature and a section plane, or between an extracted median line and an intersection plane, see [Figure 47](#). If a datum is indicated, the ACS specification element also modifies the datum feature to be in the corresponding cross-section. The cross-section applies perpendicular to the indicated datum or the situation straight line of the integral feature. The ACS specification element can only be applied to revolute surfaces, cylindrical surfaces or prismatic surfaces.
- Letters indicating locations on the feature, separated by the between symbol, if the toleranced feature is a restricted feature, see [Figure 60](#) and [Figure 63](#), or the width of the tolerance zone varies proportionally between the locations, see [Figure 10](#) and [Figure 14](#). For former practice, see [A.3.2](#).

If the specification applies to several toleranced features,  $n \times$  or several leader lines can be used to identify the toleranced features, or they can be identified as given in 9.1.2. If the toleranced features are to be considered as one united feature, the UF specification element shall be added, see Figure 48, where a cylindrical feature is defined from a collection of curved features and Figure 55, where the entire workpiece is considered one united feature. In this case, the specification defines one tolerance zone for the united feature.

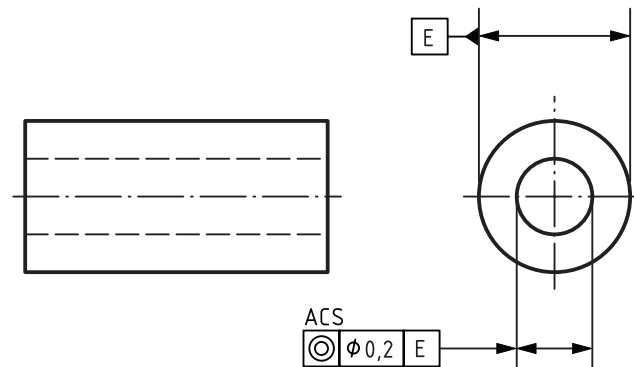


Figure 47 — Indication that the specification applies in any cross-section

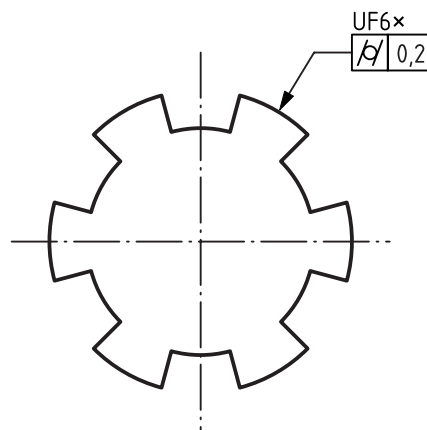


Figure 48 — Indication of a specification that applies to a united feature

Specifications for screw threads apply to the axis derived from the pitch cylinder by default. “MD” shall be indicated to designate the major diameter and “LD” to designate the minor diameter. Specifications and datums specified for splines and gears shall always designate the specific feature to which they apply, i.e. “PD” for pitch diameter, “MD” for major diameter or “LD” for minor diameter, see Figure 49.

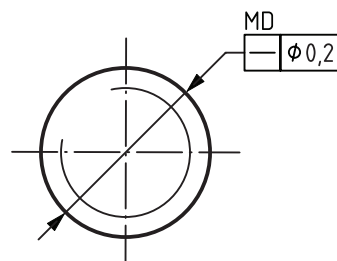


Figure 49 — Indication of a specification to the major diameter of a thread

NOTE The interpretation of geometrical specifications on the real workpiece for pitch diameter features, major diameter features and minor diameter features and features derived from these (e.g. the median line of the pitch diameter feature) are currently not well defined in GPS standards.

### 8.4.3 Patterns

Additional information can be given in an adjacent indication area to identify the features to which the specification(s) applies, see [Figure 64](#). This includes the number of patterns, the number of features within each pattern, identification of the features that belong to the pattern, and any size tolerances that apply to features of size in the pattern, to which the specification applies, as well as information about the extent of the feature(s) to which the specification applies.

For further information about patterns, see ISO 5458.

### 8.4.4 Adjacent indication sequence

If there is more than one indication in an adjacent indication area, the indications shall be given in the following sequence, with a space between each indication:

- indications of multiple toleranced features, e.g.  $n \times$  or  $n \times m \times$ , see ISO 5458;
- dimensional tolerance indication, see ISO 14405-1 and ISO 286-1;
- “between” indication(s) unrelated to United Feature, see [9.1.4](#);
- UF for United Feature and  $n \times$  for the number of features used to build each united feature, see [8.4.2](#), or “between” indications to define the extent of the united feature;
- ACS for sections, see [8.4.2](#);
- LD, PD or MD for threads and gears, see [8.4.2](#).

### 8.5 Stacked tolerance indications

If it is necessary to specify more than one geometrical characteristic for a feature, the requirements may be given in tolerance indicators one under the other for convenience (see the example in [Figure 50](#)).

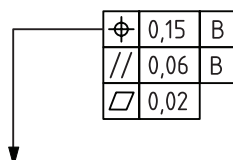


Figure 50 — Stacked tolerance indication

In this case, it is recommended that the tolerance indicators are arranged such that the tolerance values are shown in descending order from top to bottom, as shown in [Figure 50](#).

In this case, the reference line shall be attached to the mid-point of the left-hand end or the right-hand end of one of the tolerance indicators, depending on space, not as an extension of the line between the tolerance indicators. This applies both in 2D and 3D.

### 8.6 Indication of drawing defaults

ISO defaults exist for the shape of the tolerance zone, reference feature association ([8.2.2.3.1](#)), characteristic (parameter) ([8.2.2.3.2](#)) and toleranced feature (pitch diameter) for screw threads ([8.4.2](#)).

The wide range of applications of this document makes it impossible to identify a filtering default that will be applicable for a large proportion of users.

Drawing defaults for filtering can be indicated in or near the title block, either as one default for all geometrical specifications, or as separate defaults for form, orientation and location, by writing “ISO 1101”, followed by the relevant symbol from [Table 6](#) and a “:”, followed by the default filtering, see [Annex C](#).



**Table 6 — Symbols for default filtering and association**

Symbol	Meaning	Scope of default
FC	Form association criterion	Form specifications
TF	Toleranced feature filter	All form, location, orientation and runout specifications
TFF	Toleranced feature, form, filter	Form specifications
TFO	Toleranced feature, orientation, filter	Orientation specifications
TFL	Toleranced feature, location, filter	Location specifications

EXAMPLE 1 **ISO 1101 TF: G0,8- $\times$ 50-** specifies that the default filtering is a Gaussian long-pass filter with 0,8 mm cut-off for open profiles and 50 UPR for closed profiles.

The drawing default for form association can be indicated near the title block, by indicating “ISO 1101 FC”: followed by the symbol for the default association from [Table D.1](#). FC stands for “form characteristic”.

EXAMPLE 2 **ISO 1101 FC: G** specifies that the default association criterion for form is the least squares (Gaussian) feature.

## 9 Supplementary indications

### 9.1 Indications of a compound or restricted toleranced feature

#### 9.1.1 General

When the toleranced feature is a portion of a single feature, or a compound continuous feature, then it shall be indicated either as

- a continuous, closed feature (single or compound), see [9.1.2](#),
- a restricted area of a single surface, [9.1.3](#), or
- a continuous, non-closed feature (single or compound), see [9.1.4](#).

#### 9.1.2 All around and all over — Continuous, closed tolerance feature

If a geometrical specification is applied to the outlines of the cross-sections or if it is applied to all features represented by a closed outline, it shall be indicated by the symbol “all around”  $\circ$  placed on the intersection of the leader line and the reference line of the tolerance indicator (see examples [Figure 51](#) and [53](#)). A collection plane indicator shall be used to identify the collection plane in 3D and is preferred in 2D. For deprecated 2D practice, see [A.2.3](#). An all around requirement applies only to the surfaces identified by the collection plane, not to the entire workpiece (see [Figure 52](#) and [54](#)).

If a geometrical specification is applied to all integral features of a workpiece it shall be indicated by the symbol “all over”  $\odot$  (see example [Figure 55](#)).

An “all around”  $\circ$  or “all over”  $\odot$  symbol shall always be combined with an SZ (separate zones), CZ (combined zone) or UF (united feature) specification element, except in the case where the referenced datum system locks all non-redundant degrees of freedom.

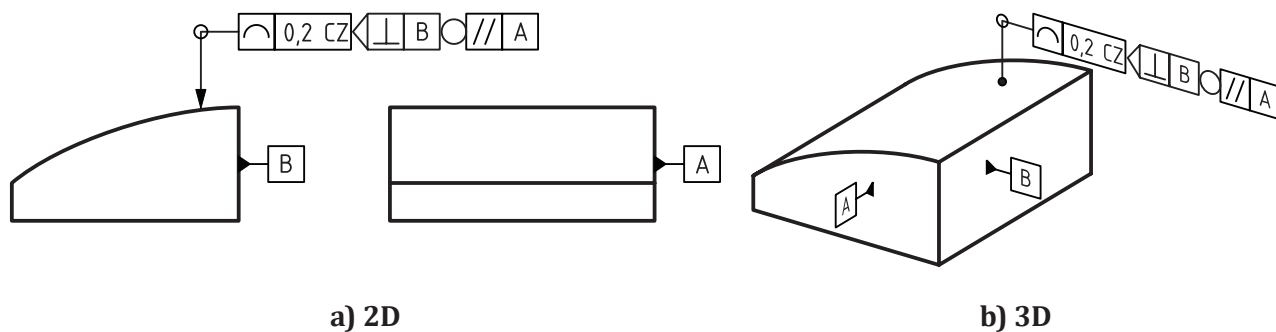
If the SZ specification element is used in conjunction with the “all around” or “all over” symbol, the characteristic shall be applied as individual requirements to the indicated features, i.e. the tolerance zones for the features are not related to each other and the use of the “all around” or “all over” symbol is equivalent to using  $n$  leader lines with one pointing to each toleranced feature, or the indication  $n\times$  adjacent to the tolerance indicator.

If the characteristic shall be applied as a pattern of zones for all the requirements to the indicated features, i.e. the tolerance zones for all the features are in a theoretically exact relationship to each

other and the transition from one tolerance zone to the next is the extensions of the two tolerance zones, resulting in sharp corners, a CZ specification element (combined zone) shall be used in conjunction with the “all around” or “all over” symbol. For former practice, see [A.3.4](#).

If the identified features shall be considered as one feature, the UF (united feature) specification element shall be used in conjunction with the “all around” or “all over” symbol.

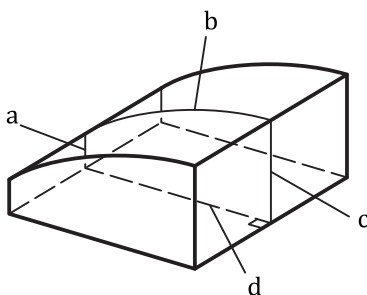
If a requirement applies to the set of line elements on the closed compound continuous surface (defined by a collection plane), an intersection plane indicator identifying the intersection plane shall also be placed between the tolerance indicator and the collection plane indicator [see [Figure 51](#) a) and b)].



NOTE 1 The drawing is incomplete. The nominal geometry of the profile is not defined.

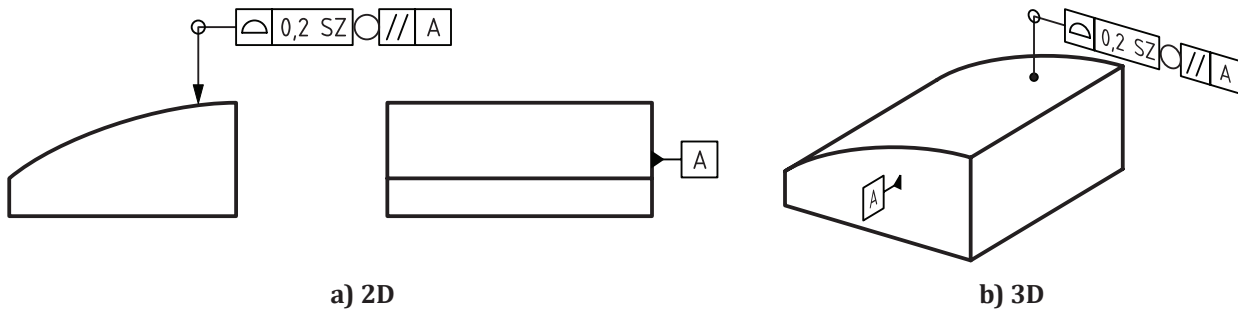
NOTE 2 When using the line profile symbol, if the intersection plane and the collection plane are the same, the collection plane symbol can be omitted.

**Figure 51 — All around drawing indication**



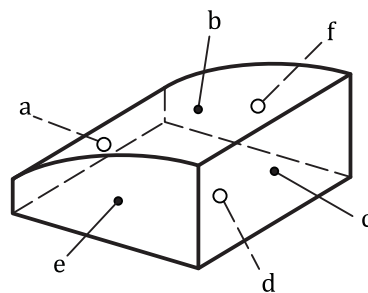
Interpretation: The requirement indicated on the drawing applies as one combined zone to the lines a, b, c and d in all cross-sections.

**Figure 52 — All around interpretation**



NOTE The drawing is incomplete. The nominal geometry of the profile is not defined.

**Figure 53 — All around drawing indication**

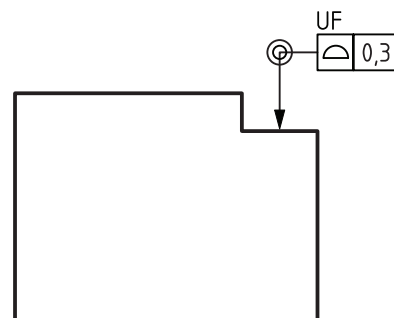


Interpretation: The requirement indicated on the drawing applies as individual requirements for the four surfaces a, b, c and d.

NOTE The all around symbol does not involve the surfaces e and f.

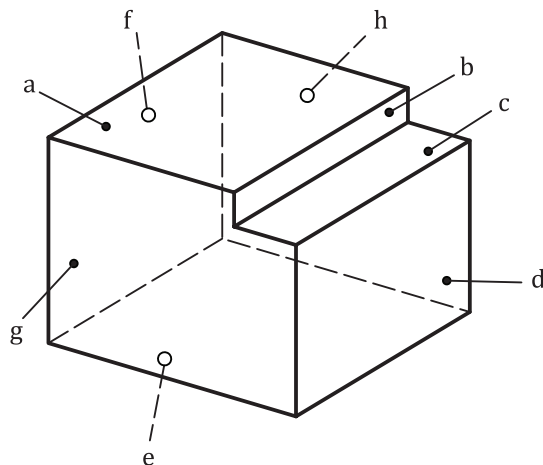
**Figure 54 — All around interpretation**

The workpiece has to be relatively simple for an “all around” indication to be unambiguous. For example, if there were a vertical hole in the middle of the workpiece shown in [Figure 51](#) and [Figure 53](#), it is not clear whether the specification would apply to the surface of the hole or not. In [Figure 51](#) and [Figure 53](#), the collection plane can be any plane parallel to datum A. Depending on where the collection plane is located, it may or may not intersect the hole. In such cases, the all around indication shall not be used.



NOTE The drawing is incomplete. The nominal geometry of the profile is not defined.

**Figure 55 — All over drawing indication**



Interpretation: The requirement applied to all the surfaces a, b, c, d, e, f, g, h, considered as one united feature.

NOTE Without UF the surfaces would have been considered independently.

**Figure 56 — All over interpretation**

### 9.1.3 Restricted area toleranced feature

The restricted area shall be defined either

- by outlining the surface portions involved using a long-dashed dotted wide line (in accordance with ISO 128-24 type 04.2). The location and dimensions shall be defined by TEDs, see [Figure 58 a](#)),
- by a hatched area with its border indicated as a long-dashed dotted wide line (in accordance with ISO 128-24 type 04.2). The location and dimensions shall be defined by TEDs, see [Figure 57 a](#)), [Figure 58 b](#)) and [Figure 59](#),
- by its corner points, indicated as crosses on the integral feature (the location of the points being defined by TEDs), identified by capital letters and leader lines terminated by an arrow. The letters are indicated above the tolerance indicator with a “between” symbol between the last two, see [Figure 57 b](#)). The border is formed by connecting the corner points with straight segments,
- by two straight border lines identified by capital letters and leader lines terminated by an arrow (the location of the border lines being defined by TEDs) combined with an indication using the “between” symbol, see [Figures 60](#) and [63](#).

The leader line starting from the reference line connected to the geometrical tolerance indication shall terminate on the restricted area.

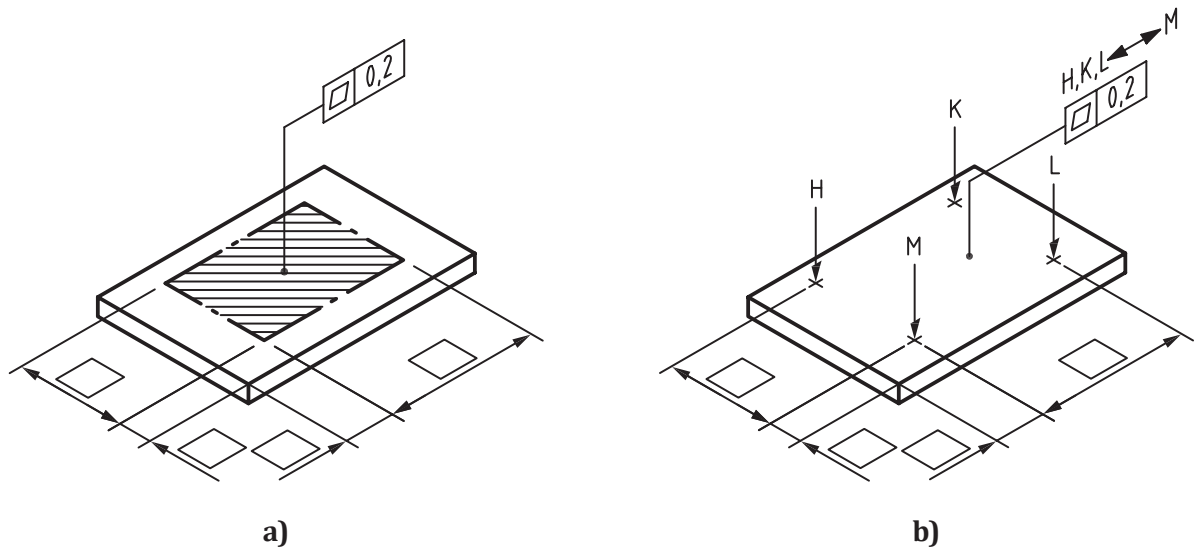


Figure 57 — Indication of restricted area

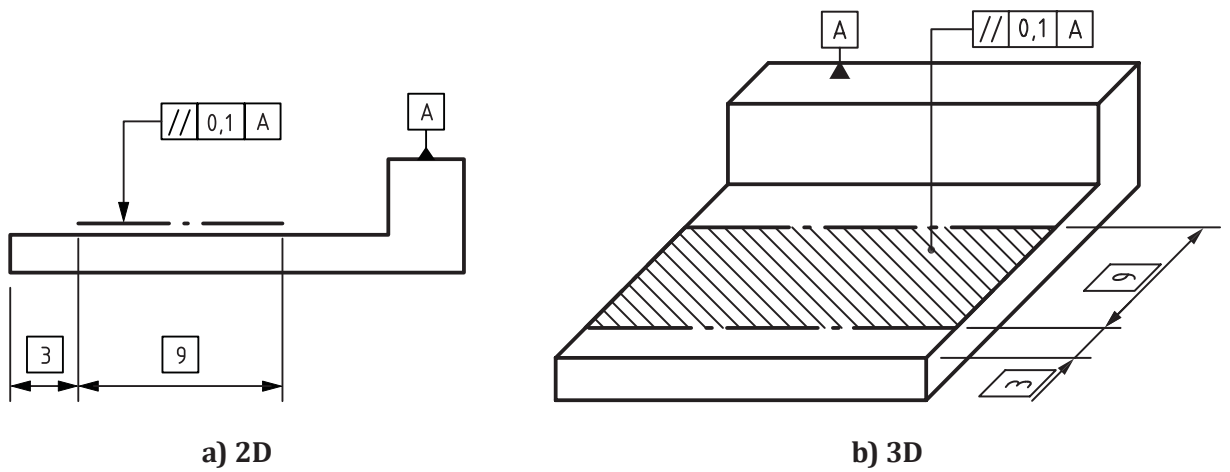


Figure 58 — Indication of restricted area

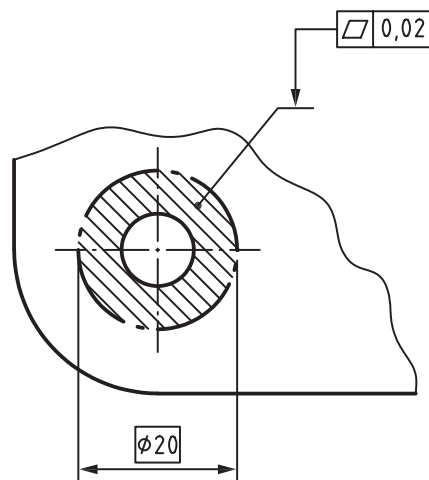


Figure 59 — Indication of restricted area

The specification applies to each surface or line element independently, unless otherwise specified (e.g. by using a CZ symbol).

#### 9.1.4 Continuous, non-closed toleranced feature

If a specification applies to one identified restricted part of a feature or to continuous restricted parts of continuous features, but does not apply to the entire outline of the cross-sections (or entire surface represented by the outline), this restriction shall be indicated by

- 1) identifying the start and the end of the toleranced feature; and
- 2) either outlining the surface portion(s) involved using a long-dashed dotted wide line (in accordance with ISO 128-24 type 04.2) or by using the symbol “ $\longleftrightarrow$ ” (called “between”).

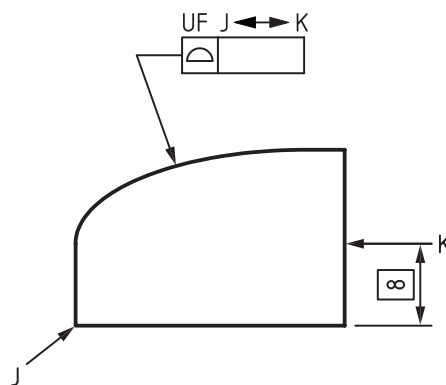
When using the between symbol, the points, lines or surfaces that identify the start and end of the toleranced feature shall each be identified by a capital letter connected to it by a leader line terminating with an arrow. If the point or line is not at the boundary of an integral feature, its location shall be indicated by TEDs.

If the toleranced feature is a derived feature, the intersection with a feature can be identified as a limit of the derived feature.

The between symbol “ $\longleftrightarrow$ ” shall be used between two capital letters that identify the start and the end of the toleranced feature. This feature (compound toleranced feature) consists of all segments or areas between the start and the end of the identified features or parts of features.

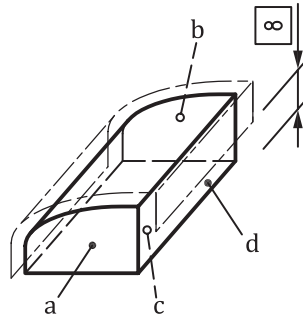
In order to clearly identify the toleranced feature, the geometrical tolerance indication shall be connected to the compound toleranced feature by a reference line and a leader line terminating with an arrow on the outline of the compound toleranced feature (see the example in [Figure 60](#)). The arrow may also be placed on a reference line using a leader line to point to the surface.

The tolerance requirement applies to each surface or line element independently, unless otherwise specified, e.g. by using a CZ symbol to combine the tolerance zones or by using the UF modifier to indicate that the compound feature shall be considered as one feature.



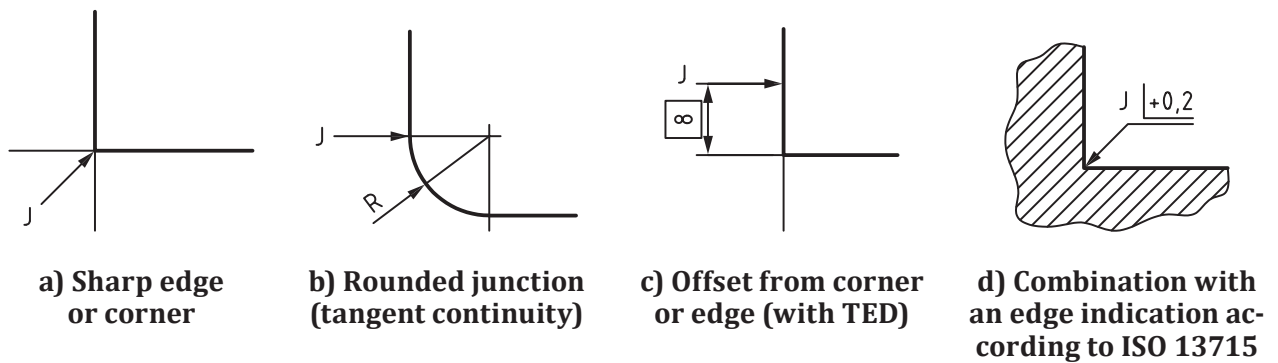
NOTE The drawing is incomplete. The nominal geometry of the profile is not defined.

**Figure 60 — Example of restricted feature — Toleranced feature is the upper surface starting at line J and finishing at line K**



**Figure 61 — Interpretation: the long-dashed line outlines the tolerated feature — Surfaces a, b, c and the lower part of d are not covered by the specification**

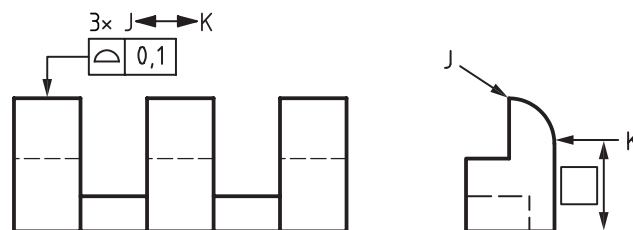
To avoid problems of interpretation regarding the considered nominal feature (see [Figure 61](#)), the start and end of the feature shall be indicated as shown in [Figure 62](#).



**Figure 62 — Indication of feature limits**

If the tolerance value is variable along the considered tolerated feature, this shall be indicated as given in [Figure 10](#).

If the same specification is applicable to a set of compound tolerated features, this set can be indicated above the tolerance indicator, see [Figure 63](#).



**Figure 63 — Indication of several compound tolerated features**

If all the compound tolerated features in the set are defined identically, it is possible to simplify the indication of this set, using the “ $n \times$ ” indication (see [8.4](#)).

## 9.2 Moveable assemblies

ISO/TS 17863:2013 provides additional symbology for moveable assemblies.

## 10 Theoretically exact dimensions (TED)

If location, orientation or profile specifications are indicated for a feature or a group of features, the dimensions determining the theoretically exact location, orientation or profile, respectively, are called theoretically exact dimensions (TED). TED can be explicit or implicit.

TED shall also be used to indicate the angles between the datums in a datum system.

TED shall not be toleranced. They are to be enclosed in a frame (see the examples in [Figures 64](#) and [65](#)).

TEDs or CAD data shall be used to define the nominal geometry of complex surfaces (i.e. non-flat surfaces).

TEDs shall be used if the requirements are related, i.e. if tolerance zones shall maintain a theoretically exact relationship to each other and/or be treated as one tolerance zone.

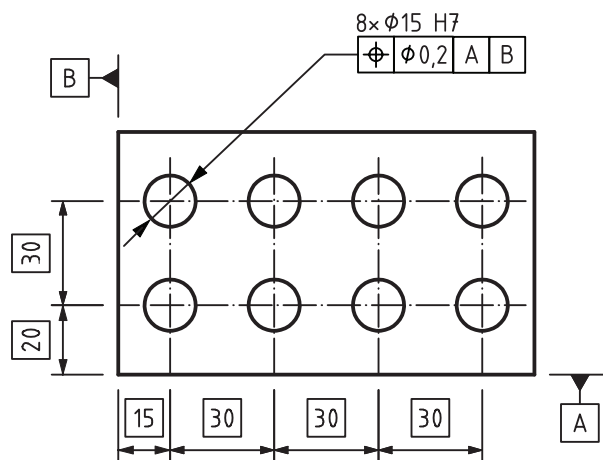


Figure 64 — Indication of linear TEDs

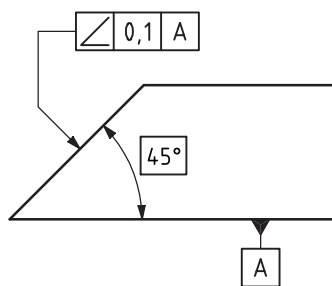


Figure 65 — Indication of an angular TED

TEDs may be extracted from the profile of the nominal model in the CAD file. When this is the case, it shall be indicated near the title block.

NOTE This indication can, for example, be formulated as: “TED’s according to CAD model 12345 rev abc”. See also ISO 16792.

## 11 Restrictive specifications

If a specification of the same characteristic is applied to a restricted length, lying anywhere within the total extent of the feature, the value of the restricted length shall be added after the tolerance value and separated from it by an oblique stroke [see the example in [Figure 66 a](#)]. If two or more specifications of the same characteristic are to be indicated, they may be combined as shown in [Figure 66 b](#)).





**Figure 66 — Indication of restrictive specifications**

The following restricted area shapes can be indicated for a specification of the same characteristic applied to a restricted area, lying anywhere within the total extent of the feature:

- any rectangular restricted area with the length and height separated by a “×”. The area can translate in both directions. An orientation plane indicator shall be used to indicate the direction to which the first value applies as shown in [Figure 67](#);

EXAMPLE “75×50”.

- any circular restricted area, indicated by a diameter symbol followed by the diameter value;

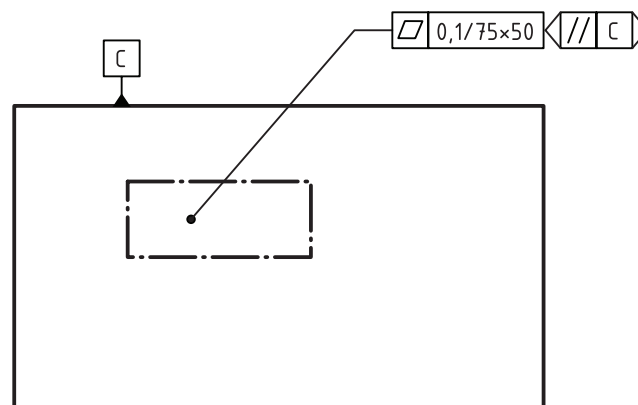
EXAMPLE “ø4”.

- any cylindrical area defined by a length in the direction of the axis of the cylinder, followed by an “×” and an angle for the circumferential dimension. The area can translate along and rotate around the axis or the cylinder;

EXAMPLE “75×30°”.

- any spherical area, defined by two perpendicular angular dimensions separated by “×”. The area can rotate in both directions. An orientation plane indicator shall be used to indicate the direction to which the first value applies.

EXAMPLE “10°×20°”.

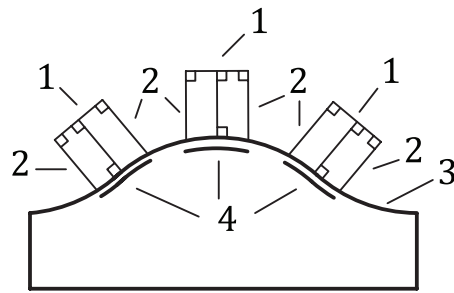


**Figure 67 — Indication of an areal restricted specification**

The aspect ratio of the area can be exaggerated for clarity as shown in [Figure 67](#).

For linear restricted portions, the restricted portion is defined as a line identified by an orthogonal projection of a line of the indicated length onto the tolerated feature, with the centre of the line aligned perpendicular to the normal of the tolerated feature at this point, see [Figure 68](#).

NOTE The curvilinear length of the restricted portion is longer than the length indicated after the oblique stroke, unless the tolerated feature is a nominally straight line.



**Key**

- 1 examples of lines of the length indicated after the oblique stroke, which are parallel to the tangent lines of the tolerated feature at their mid-points. One of these lines exists for each point along the tolerated feature
- 2 perpendicular projections of the end points of the lines (1) onto the tolerated feature
- 3 tolerated feature
- 4 restricted portions of the tolerated feature

**Figure 68 — Linear restricted portion of a tolerated feature**

For areal restricted portions, the restricted portion is defined as an area identified by an orthogonal projection of the indicated shape onto the tolerated feature with the centre of the indicated shape aligned perpendicular to the normal of the tolerated feature at this point.

**NOTE** The area of the restricted portion is larger than the area indicated after the oblique stroke, unless the tolerated feature is nominally planar.

Because of the feature principle and the independency principle, see ISO 8015, when a form requirement is limited to a restricted portion of the feature or any restricted portion of the feature, only the restricted portion shall be considered when associating the reference feature, see ISO 25378.

**12 Projected tolerated feature**

The modifier  $\textcircled{P}$  after the tolerance value in the second compartment of the tolerance indicator shall be used to indicate a projected tolerated feature; see [Figures 69](#) and [70](#). In this case, the tolerated feature is either a portion of the extended feature or its derived feature (see [Clause 6](#) and [Table 7](#)).

The extended feature is an associated feature constructed from the integral feature. The default association criterion for the extended feature is a minimized maximum distance between the indicated integral feature and the associated feature with the additional constraint of external contact of material.

**Table 7 — Feature tolerated with the projected tolerance modifier**

The leader line from the tolerance indicator points	Tolerated feature
On a cylinder (but not in extension of a dimension line)	Portion of the associated cylinder
In extension of a dimension line of a cylinder	Portion of the axis of the associated cylinder
On a plane (but not in extension of a dimension line)	Portion of the associated plane
In extension of a dimension line of two opposite parallel planes	Portion of the median plane of two associated parallel planes

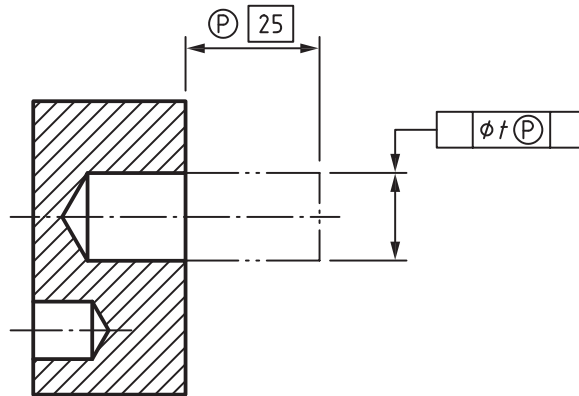
For associated planes, the width and location of the extended plane in the direction perpendicular to the projection is equal to the width and location of the plane defining the projected tolerated feature.

The limits of the relevant portion of this extended feature shall be clearly defined and shall be indicated either directly or indirectly, as follows.

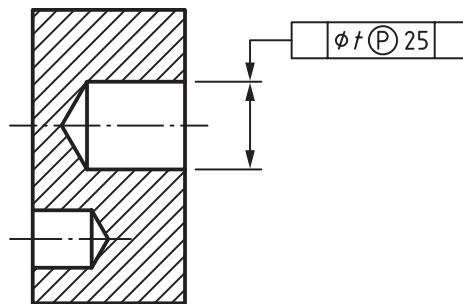
When indicating the projected tolerated feature length directly on the drawing by a “virtual” integral feature representing the portion of the extended feature to be considered, this virtual feature shall be

indicated by use of a long-dashed double-dotted narrow line (line type 05.1 according to ISO 128-24), and the length of the extension shall be indicated with the modifier  $\text{\textcircled{P}}$  prior to the Theoretically Exact Dimension (TED) value. See [Figure 69](#)).

When indicating the length of the projected toleranced feature indirectly in the tolerance indicator, the value shall be indicated after the modifier  $\text{\textcircled{P}}$ . See [Figure 70](#)). In this case, the representation of the extended feature with a long-dashed double-dotted narrow line shall be omitted. This indirect indication shall only be used for blind holes.

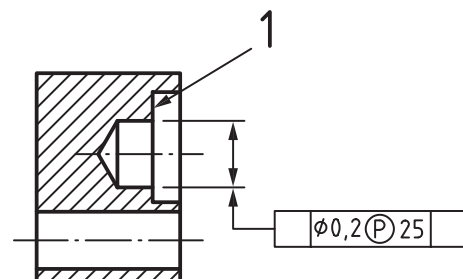


**Figure 69 — Indication of a geometrical specification with projected tolerance modifier using direct indication of the length of the extension by a TED**



**Figure 70 — Indication of a geometrical specification with projected tolerance modifier using indirect indication of the length of the projected toleranced feature in the tolerance indicator**

The origin of the projected feature shall be constructed from the reference plane. The reference plane is the first plane intersecting the considered feature. See [Figure 71](#). This real feature shall be considered to define the reference plane. The reference plane is an associated plane to this real feature. See [Figure 74](#).



**Key**

- 1 reference plane defining the start of the toleranced feature

**Figure 71 — Reference plane of the projected feature**

By default, the origin of the projected feature shall be at the location of the reference plane, and the end corresponds to the shift of the projected feature's length from its origin in the direction out of the material.

If the origin of the projected feature is displaced from the reference surface by an offset, this shall be indicated as follows.

- When directly indicated, the offset shall be specified by a theoretically exact dimension (TED); see [Figure 72](#).
- When indirectly indicated, the first value after the modifier indicates the distance to the farthest limit of the extended feature and the second value (offset value), which is preceded by a minus sign, indicates the distance to the nearest limit of the extended feature (the length of the extended feature is the difference between these two values), e.g.  $\varnothing t \text{ } \textcircled{P} \text{ } 32\text{-}7$ ; see [Figure 73](#). An offset value of zero shall not be indicated and the minus sign shall be omitted in this case; see [Figure 70](#).

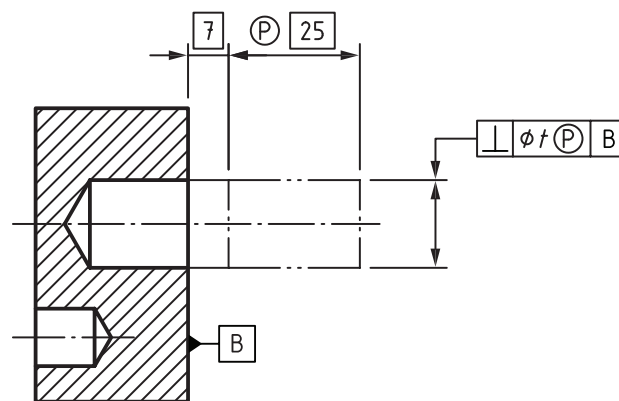
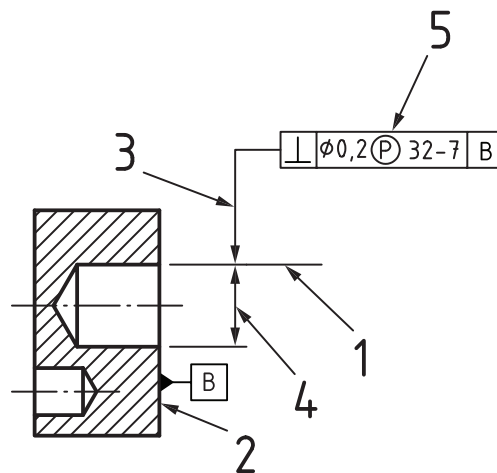


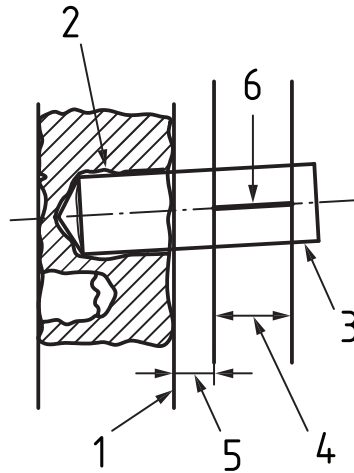
Figure 72 — Example of direct indication of a projected tolerance with an offset



**Key**

- 1 extension line
- 2 reference surface
- 3 leader line connected to the tolerance indicator
- 4 indication showing that the type of the tolerated feature is a median feature (equivalent to the modifier  $\textcircled{A}$ )
- 5 modifier indicating that the specification applies to a portion of an extended feature and is limited by the following values

Figure 73 — Indirect indication of a projected tolerance with an offset

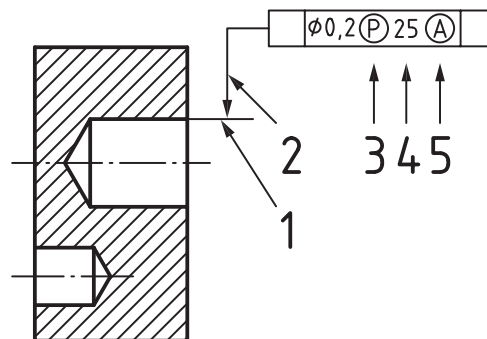


**Key**

- 1 associated reference plane
- 2 integral surface
- 3 associated feature
- 4 length of the projected toleranced feature, in this case 25 mm (= 32 – 7)
- 5 offset of the projected toleranced feature from the reference plane, in this case 7 mm
- 6 projected toleranced feature

**Figure 74 — Interpretation of indirect indication of a projected tolerance with an offset**

The modifier  $\textcircled{P}$  may be used with other types of specification modifiers as appropriate; see [Figure 75](#).



**Key**

- 1 extension line
- 2 leader line connected to the tolerance indicator
- 3 modifier indicating that the specification applies to a portion of an extended feature and is limited by the subsequent information (4)
- 4 length of projected toleranced feature, in this case 25 mm
- 5 modifier indicating that the type of the toleranced feature is a median feature

**Figure 75 — Example of use of a projected tolerance zone together with a median feature modifier**

## 13 Intersection planes

### 13.1 Role of intersection planes

Intersection planes shall be used to identify the orientation of line requirements, e.g. straightness of a line in a plane, line profile, orientation of a line element of a feature, see [Figure 90](#), and “all around” specifications for lines on surfaces.

### 13.2 Features to be used for establishing a family of intersection planes

Only surfaces belonging to one of the following invariance classes shall be used to establish a family of intersection planes (see ISO 17450-1):

- revolute (e.g. a cone or a torus);
- cylindrical (i.e. a cylinder);
- planar (i.e. a plane).

### 13.3 Graphical language

The intersection plane shall be specified through an intersection plane indicator placed as an extension to the right of the tolerance indicator (see [Figure 76](#)).



**Figure 76 — Intersection plane indicator**

If necessary, the reference line can be attached to the intersection plane indicator instead of the tolerance indicator, see [Figure 46](#). The symbol defining how the intersection plane is constructed from the datum is placed in the first compartment of the intersection plane indicator. The symbols stand for:

- |    |                             |
|----|-----------------------------|
| // | parallel;                   |
| ⊥  | perpendicular;              |
| ∠  | at a defined angle;         |
| ≡  | symmetrical to (including). |

**NOTE** The symmetry symbol is used to indicate that the intersection plane includes (is symmetrical around) the datum.

The letter identifying the datum used to establish the intersection plane is placed in the second compartment of the intersection plane indicator.

### 13.4 Rules

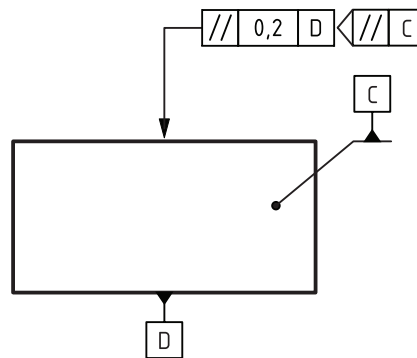
For geometrical specifications that include intersection plane indicators, the following applies.

When the toleranced feature is a line on an integral feature, an intersection plane shall be indicated to avoid misinterpretation of the toleranced feature, except in the case of generatrix straightness or roundness of a cylinder, a cone or a sphere.

For deprecated practice, see [A.2.1](#) and [A.2.2](#).

When the toleranced feature is all the lines in a feature in a given direction, and the characteristic symbol does not explicitly indicate whether the toleranced feature is the planar feature or the lines in

the feature, an intersection plane indicator shall be used to indicate that the tolerated feature is the lines in the feature and the direction of the lines, see [Figure 77](#), where the tolerated feature is all lines in the surface parallel to datum C.



**Figure 77 — Specification using an intersection plane indicator**

The intersection plane shall be established parallel to, perpendicular to, at a defined angle to or symmetrical to (including) the datum given in the second compartment of the intersection plane indicator, but without additional orientation constraints.

In some cases, an intersection plane will have an unlocked degree of freedom. In that case by default, the intersection plane will be perpendicular to the tolerated feature. When a direction feature is added, the effect is to reorient the intersection plane.

**NOTE** The exact constraints of how the direction feature reorients the intersection plane are not fully detailed in this document.

The possible intersection planes are given in [Table 8](#). They depend on the datum used to establish the intersection plane and how the plane is constructed from this datum (as defined by the symbol indicated).

**Table 8 — Application cases of intersection plane**

Indicated datum	Intersection plane			
	Parallel to	Perpendicular to	At defined angle to	Symmetrical to (including)
Axis of revolute surface (cylinder or cone)	Not applicable	OK <sup>b</sup>	OK	OK <sup>d</sup>
Plane (integral or median)	OK <sup>a</sup>	OK <sup>c</sup>	OK	Not applicable
<sup>a</sup> See <a href="#">Figure 78</a> .				
<sup>b</sup> See <a href="#">Figure 79</a> .				
<sup>c</sup> See <a href="#">Figure 80</a> .				
<sup>d</sup> See <a href="#">Figure 81</a> .				

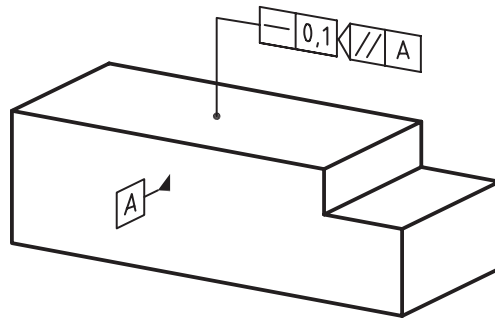


Figure 78 — Specification using an intersection plane parallel to the datum

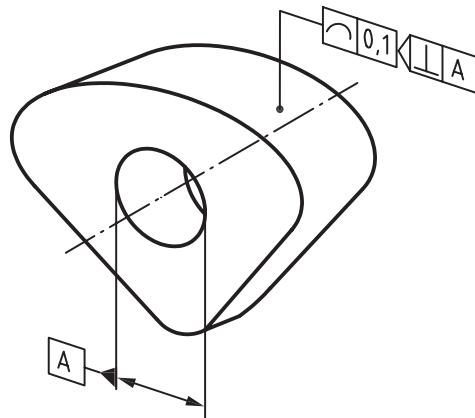


Figure 79 — Specification using an intersection plane perpendicular to the datum

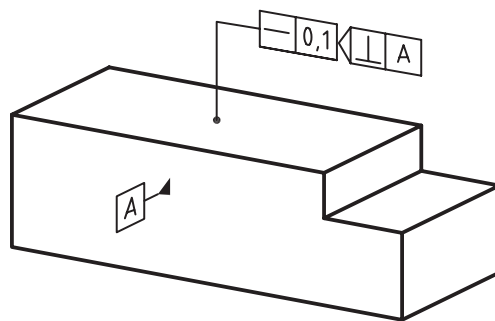


Figure 80 — Specification using an intersection plane perpendicular to the datum

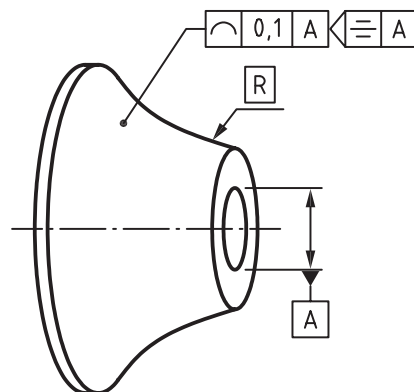


Figure 81 — Specification using an intersection plane symmetrical to (including) the datum



## 14 Orientation planes

### 14.1 Role of orientation planes

Orientation planes shall be indicated when

- the toleranced feature is a median line or a median point, and the width of the tolerance zone is limited by two parallel planes, or
- the toleranced feature is a median point, and the tolerance zone is limited by a cylinder, and
- the tolerance zone is oriented from another feature, established from an extracted feature of the workpiece, identifying the orientation of the tolerance zone.

See [Figures 83, 84, 112, 114](#) and [116](#).

The orientation plane indicator controls both the orientation of the planes that limit the tolerance zone (directly by the datum and the symbol in the indicator) and the orientation of the width of the tolerance zone (indirectly, perpendicular to the planes), or the orientation of the axis for a cylindrical tolerance zone. See [Figures 112, 114, 116, 130](#) and [132](#).

Orientation planes shall also be indicated when it is necessary to define the orientation of a rectangular restricted area, see [Figure 67](#).

### 14.2 Features to be used for establishing orientation planes

Only surfaces belonging to one of the following invariance classes shall be used to establish orientation planes (see ISO 17450-1):

- revolute (e.g. a cone or a torus);
- cylindrical (i.e. a cylinder);
- planar (i.e. a plane).

### 14.3 Graphical language

The orientation plane shall be specified through an orientation plane indicator placed to the right of the tolerance indicator (see [Figure 82](#)):



**Figure 82 — Orientation plane indicator**

If necessary, the reference line can be attached to the orientation plane indicator instead of the tolerance indicator, see [Figure 46](#). The orientation symbol for parallelism, perpendicularity or angularity is placed in the first compartment of the orientation plane indicator.

The letter identifying the datum used to establish the orientation plane is placed in the second compartment of the orientation plane indicator.

### 14.4 Rules

For geometrical specifications that include orientation plane indicators, the following applies.

The orientation plane shall be established parallel to, perpendicular to, or at a defined angle from the datum indicated in the second compartment of the orientation plane indicator as follows:

- when the orientation plane is defined with an angle different from 0° or 90°, the angularity symbol shall be used and an explicit theoretical angle shall be defined between the orientation plane and the datum in the orientation plane indicator;
- when the orientation plane is defined with an angle equal to 0° or 90°, the parallelism symbol or perpendicularity symbol shall be used respectively.

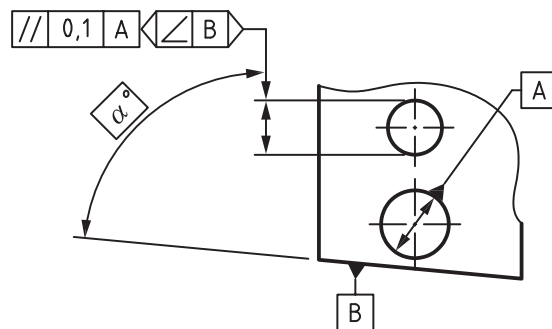
When the tolerance indicator indicates one or more datums, then the orientation plane is established parallel to, perpendicular to, or at a defined angle from a plane defined by the orientation plane indicator with constraints (an implicit angle of 0° or 90° or an explicit stated angle defined by a TED) from the datum(s) of the tolerance indicator. The datums in the tolerance indicator are applied in the specified order before the plane given in the orientation plane indicator is established. If the datum indicated in the orientation plane indicator is also indicated in the tolerance indicator, then it is only constrained by the datums preceding it in the tolerance indicator.

The possible orientation planes are given in Table 9. They depend on the datum used to establish the orientation plane and how the plane is derived from this datum (as defined by the symbol indicated).

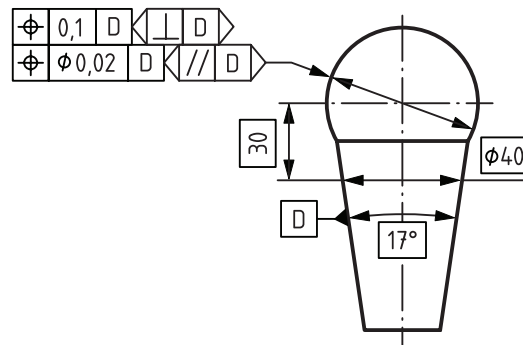
**Table 9 — Application cases of orientation plane**

Indicated datum	Tolerance zone	Orientation plane		
		Parallel to	Perpendicular to	Inclined to
Axis of revolute surface (cylinder or cone)	Two parallel planes	Not applicable	OK	OK
	Cylindrical	OK	OK	OK
Plane (integral or median)	Two parallel planes	OK	OK	OK
	Cylindrical	Not applicable	OK	OK

Examples are given in Figures 83 and 84.



**Figure 83 — Specification using an orientation plane at a specified angle to the datum**



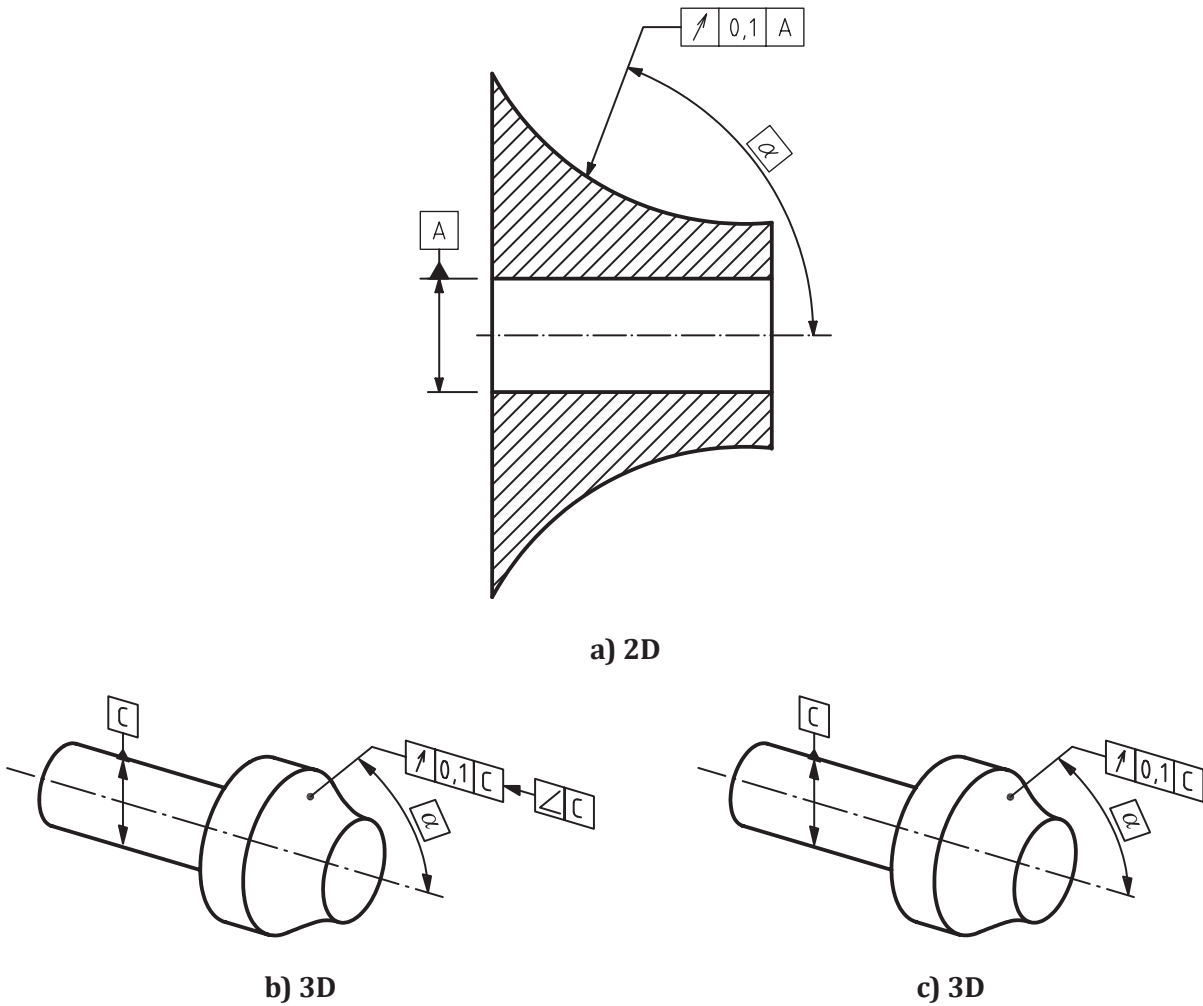
**Figure 84 — Specification using orientation planes to orient both a cylindrical tolerance zone and a tolerance zone limited by two parallel planes**

## 15 Direction feature

### 15.1 Role of direction features

Direction features shall be used to orientate the direction of the width of the tolerance zone when the tolerated feature is an integral feature and the local width of the tolerance zone is not perpendicular to the surface. In addition, for roundness of revolute surfaces that are neither cylindrical nor spherical, a direction feature shall always be used to indicate the direction of the width of the tolerance zone.

In 2D, the orientation of the leader line shall define the direction of the width of the tolerance zone only when the orientation of the leader line and therefore the direction of the width of the tolerance zone is indicated by a TED, see [Figure 85 a](#)).

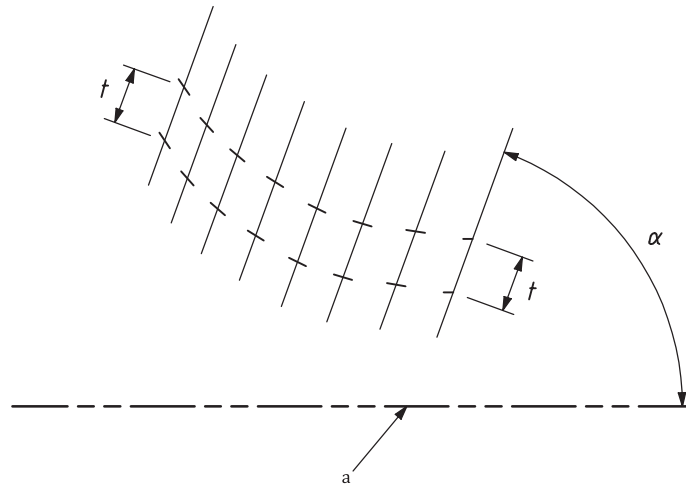


**Figure 85 — Drawing indication**

NOTE 1 When the datum feature identified by the tolerance indicator is the same as the feature establishing the direction feature, then the direction feature can be omitted, i.e. b) and c) have the same meaning.

NOTE 2 In [Figure 85](#), the theoretical shape of each tolerated feature is a circle. The straight segments are inclined by the angle  $\alpha$ . This generates a set of tolerance zones which are conical sections with a fixed angle along the surface.

When a direction feature is indicated as shown in [Figure 85 b\)](#) or implied as in [Figure 85 c\)](#), the width of the tolerance zones is defined by an infinite set of straight segments, inclined in the direction indicated by the direction feature indicator (see [Figure 86](#)). Each of these segments has a length equal to the tolerance value and has its midpoint located on the theoretical shape of the tolerance zone by default.



a Datum A.

**Figure 86 — Interpretation**

The angle  $\alpha$  shown in [Figure 85](#) shall be indicated, even if it is equal to  $90^\circ$ .

### 15.2 Features to be used for establishing direction features

Only surfaces belonging to one of the following invariance classes shall be used to establish direction features (see ISO 17450-1):

- revolute (e.g. a cone or a torus);
- cylindrical (i.e. a cylinder);
- planar (i.e. a plane).

### 15.3 Graphical language

When applied, the direction feature indicator, see [Figure 87](#), shall be placed as an extension to the right of the tolerance indicator.



**Figure 87 — Direction feature indicator**

If necessary, the reference line can be attached to the direction feature indicator instead of the tolerance indicator, see [Figure 46](#). The direction symbol for parallelism, perpendicularity, angularity or run-out shall be placed in the first compartment of the direction feature indicator.

**NOTE** The run-out symbol is used to imply that the direction of the width of the tolerance zone is equal to run-out, i.e. perpendicular to the surface of the tolerated feature, see e.g. [Figure 182](#)

The letter identifying the datum used to establish the direction feature shall be placed in the second compartment of the direction feature indicator (see [Figure 87](#)).

### 15.4 Rules

A direction feature shall be indicated when

- the tolerated feature is an integral feature, and

- the width of the tolerance zone is not normal to the specified geometry, or
- a roundness specification is applied to a revolute surface that is neither cylindrical nor spherical, see [Figure 88](#).

For geometrical specifications that include direction feature indicators, the following applies.

The direction of the width of the tolerance zone is established from the datum indicated in the direction feature indicator as follows:

- when the direction is defined as perpendicular to the surface of the tolerated feature, the run-out symbol shall be used and the tolerated feature (or its derived feature) shall be indicated as the datum in the direction feature indicator,
- when the direction is defined with an angle equal to 0° or 90°, the parallelism symbol or perpendicularity symbol shall be used, respectively,
- when the direction is defined with an angle different from 0° or 90°, the angularity symbol shall be used and an explicit TED angle shall be defined between the direction feature and the datum of the direction feature indicator.

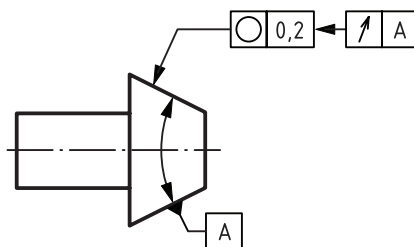
The possible direction features are given in [Table 10](#). They depend on the datum used to establish the direction feature and how the direction is derived from this datum (as defined by the symbol indicated).

**Table 10 — Application cases of direction feature**

Indicated datum	Direction feature			
	Parallel to	Perpendicular to	Inclined to	Run-out to
Axis of revolute surface (e.g. cylinder or cone)	OK	OK	OK	OK <sup>a</sup>
Plane (integral or median)	OK	OK	OK	Not applicable

<sup>a</sup> Run-out can only be used with the tolerated feature itself indicated as the datum and in this case the direction is given by the surface of the tolerated feature itself, not its derived feature.

An example is given in [Figure 85](#).



**Figure 88 — Indication of a roundness specification perpendicular to the surface of the tolerated feature**

For former practice, see [A.3.3](#).

## 16 Collection plane

### 16.1 Role of collection planes

Collection planes shall be used when the “all around” symbol is applied. The collection plane identifies a family of parallel planes, which identifies the features covered by the “all around” indication.

## 16.2 Features to be used for establishing collection planes

The same types of features that can be used for intersection planes can also be used to establish collection planes.

## 16.3 Graphical language

When applied, the collection plane indicator, see [Figure 89](#), shall be placed as an extension to the right of the tolerance indicator.



NOTE The same symbols that can be used in the first compartment of the intersection plane indicator can also be used in the first compartment of the collection plane indicator with identical meaning.

**Figure 89 — Collection plane indicator**

## 16.4 Rules

A collection plane shall be indicated when the “all around” symbol is used to identify that a specification applies to a collection of features. A collection plane identifies a set of single features whose intersection with any plane parallel to the collection plane is a line or a point.

For examples, see [Figure 51](#) and [Figure 53](#).

# 17 Definitions of geometrical specifications

## 17.1 General

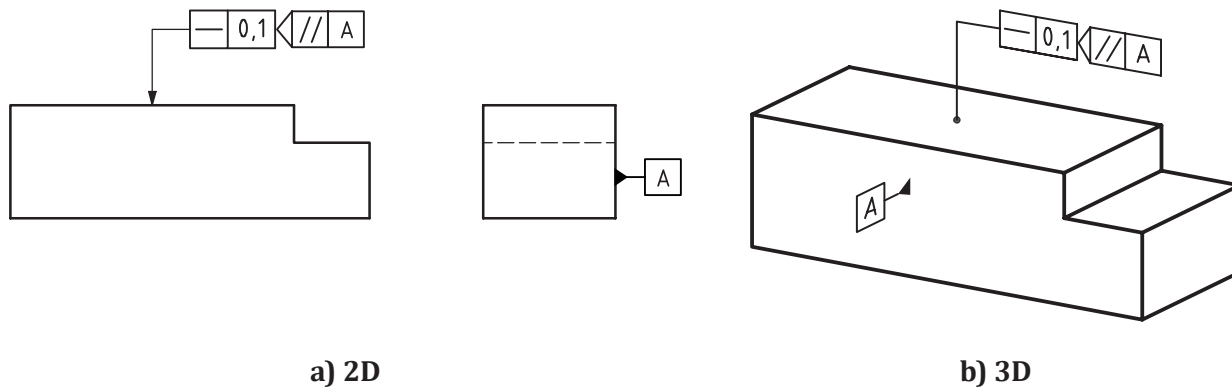
An explanation based on examples of the various geometrical specifications and their tolerance zones are provided in this clause. The illustrations accompanying the definitions only show those deviations which relate to the specific definition. The underlying rules are summarized in [Annex B](#).

NOTE The 3D illustrations in ISO 1101 are intended to illustrate how a specification can be fully indicated with visible annotation. Alternatively, the same specification can be indicated in accordance with ISO 16792. In this case, it is possible that some elements of the specification are available through a query function or other interrogation of information on the model instead of being indicated using visible annotation.

## 17.2 Straightness specification

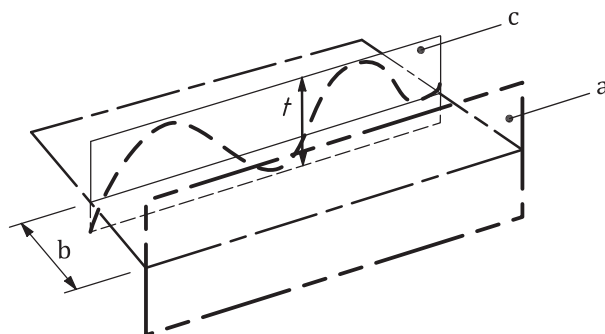
The toleranced feature can be an integral feature or a derived feature. The nature and shape of the nominal toleranced feature is explicitly given as a straight line or a set of straight lines, which is a linear feature.

In [Figure 90](#), any extracted line on the upper surface, as specified by the intersection plane indicator, shall be contained between two parallel straight lines 0,1 apart. For deprecated 2D practice, see [A.2.1](#).



**Figure 90 — Straightness indication**

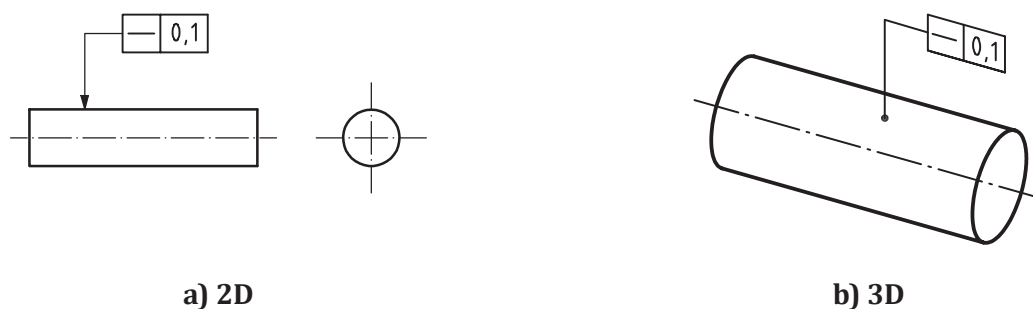
The tolerance zone defined by the specification in [Figure 90](#), in the considered plane parallel to datum A, is limited by two parallel straight lines a distance  $t$  apart and in the specified direction only, see [Figure 91](#).



- a Datum A.
- b Any distance.
- c Intersection plane parallel to datum A.

**Figure 91 — Definition of the straightness tolerance zone**

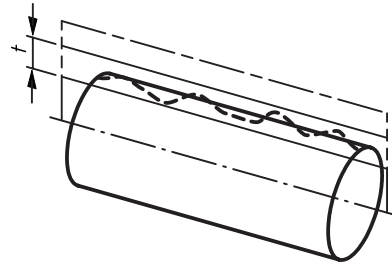
In [Figure 92](#), any extracted longitudinal section line on the cylindrical surface shall be contained between two parallel lines 0,1 apart.



**Figure 92 — Straightness indication**

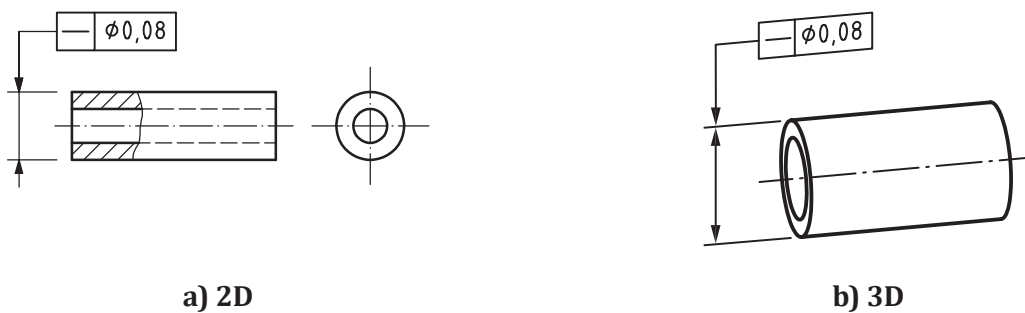
The tolerance zone defined by the specification in [Figure 92](#) is limited by two parallel lines a distance  $t$  apart in a plane that includes the axis of the cylinder, see [Figure 93](#).





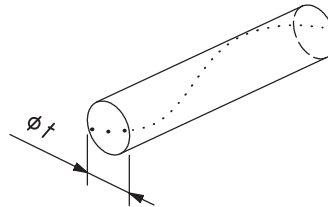
**Figure 93 — Definition of the straightness tolerance zone**

In [Figure 94](#), the extracted median line of the cylinder to which the specification applies shall be contained within a cylindrical zone of diameter 0,08.



**Figure 94 — Straightness indication**

The tolerance zone defined by the specification in [Figure 94](#) is limited by a cylinder of diameter  $t$ , if the tolerance value is preceded by the symbol  $\phi$ , see [Figure 95](#).

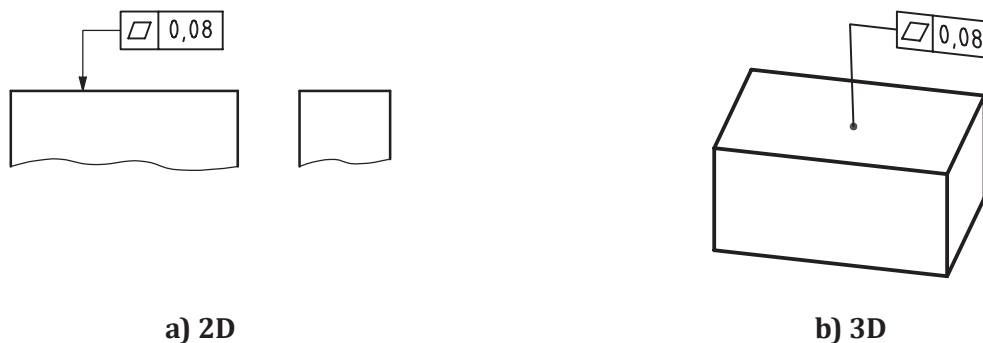


**Figure 95 — Definition of the straightness tolerance zone**

### 17.3 Flatness specification

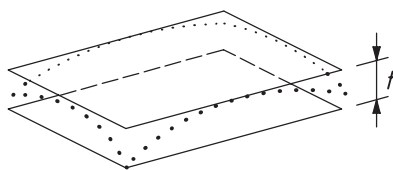
The tolerated feature can be an integral feature or a derived feature. The nature and shape of the nominal tolerated feature is explicitly given as a flat surface, which is an areal feature.

In [Figure 96](#), the extracted surface shall be contained between two parallel planes 0,08 apart.



**Figure 96 — Flatness indication**

The tolerance zone defined by the specification in [Figure 96](#) is limited by two parallel planes a distance  $t$  apart, see [Figure 97](#).



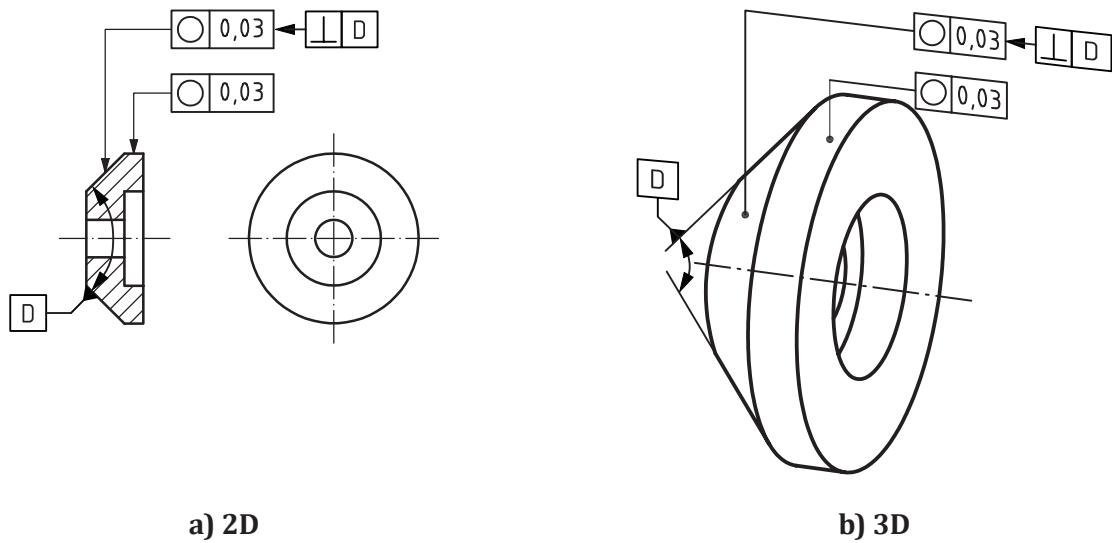
**Figure 97 — Definition of the flatness tolerance zone**

### 17.4 Roundness specification

The tolerated feature is an integral feature. The nature and shape of the nominal tolerated feature is explicitly given as a circular line or a set of circular lines, which is a linear feature.

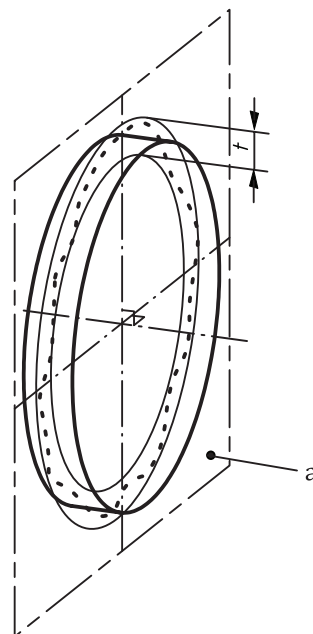
For cylindrical features, roundness applies in cross-sections perpendicular to the axis of the tolerated feature. For spherical features, roundness applies in cross-sections that include the centre of the sphere. For revolute surfaces that are neither cylindrical nor spherical, a direction feature shall always be indicated, see [Clause 15](#).

In [Figure 98](#), for both the cylindrical and conical surfaces, the extracted circumferential line, in any cross-section of the surfaces, shall be contained between two coplanar concentric circles, with a difference in radii of 0,03. This is the default for the cylindrical surface and indicated by the direction feature indicator for the conical surface. A direction feature shall always be indicated for conical surfaces.



**Figure 98 — Roundness indication**

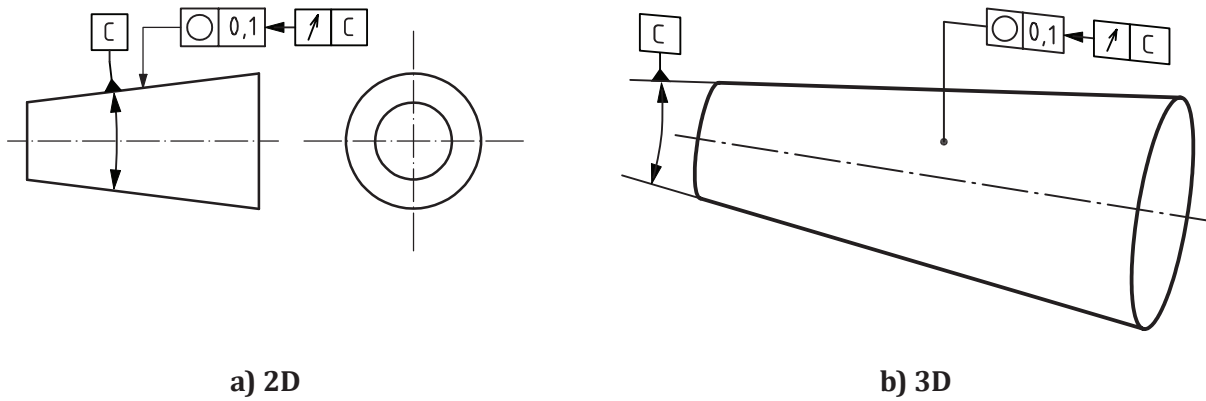
The tolerance zone defined by the specification in [Figure 98](#), in the considered cross-section, is limited by two concentric circles with a difference in radii of  $t$ , see [Figure 99](#).



a Any intersection plane (any cross-section).

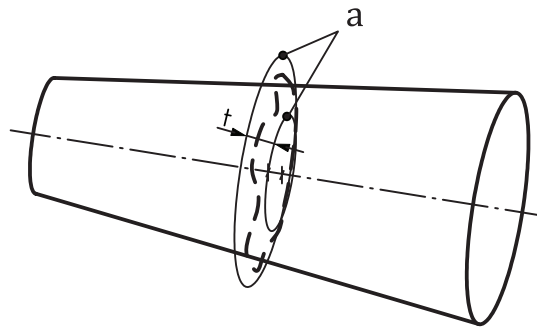
**Figure 99 — Definition of the roundness tolerance zone**

In [Figure 100](#), an extracted circumferential line exists in any cross-section of the surface defined by an intersection of the tolerated feature with a cone that is coaxial with the tolerated feature and has a cone angle such that the cone is perpendicular to the tolerated feature. This extracted circumferential line shall be contained between two circles on the intersecting cone separated by  $0,1$ , i.e. a tolerance zone that is perpendicular to the surface of the tolerated feature, as indicated by the direction indicator. A direction indicator shall always be indicated for roundness of conical features.



**Figure 100 — Roundness indication**

The tolerance zone defined by the specification in [Figure 100](#), in the considered cross-section, is limited by two circles on a conical surface a distance  $t$  apart along the surface, see [Figure 101](#).



- a Circles perpendicular to datum C (the axis of the tolerated feature), on a conical surface perpendicular to the surface of the tolerated feature.

**Figure 101 — Definition of the roundness tolerance zone**

The direction feature indicator, which shall always be indicated for revolute surfaces that are neither cylindrical nor spherical, can be used to indicate roundness perpendicular to the surface or at a defined angle to the axis of the tolerated feature, see [Clause 15](#). For former practice, see [A.3.3](#).

### 17.5 Cylindricity specification

The tolerated feature is an integral feature. The nature and shape of the nominal tolerated feature is explicitly given as a cylindrical surface, which is an areal feature.

In [Figure 102](#), the extracted cylindrical surface shall be contained between two coaxial cylinders with a difference in radii of 0,1.

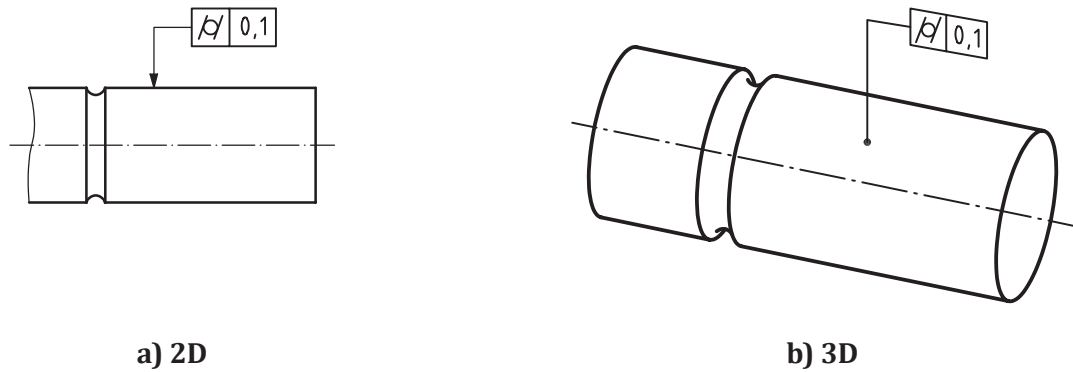


Figure 102 — Cylindricity indication

The tolerance zone defined by the specification in [Figure 102](#), is limited by two coaxial cylinders with a difference in radii of  $t$ , see [Figure 103](#).

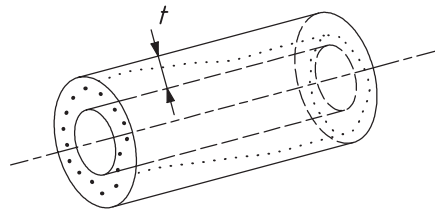
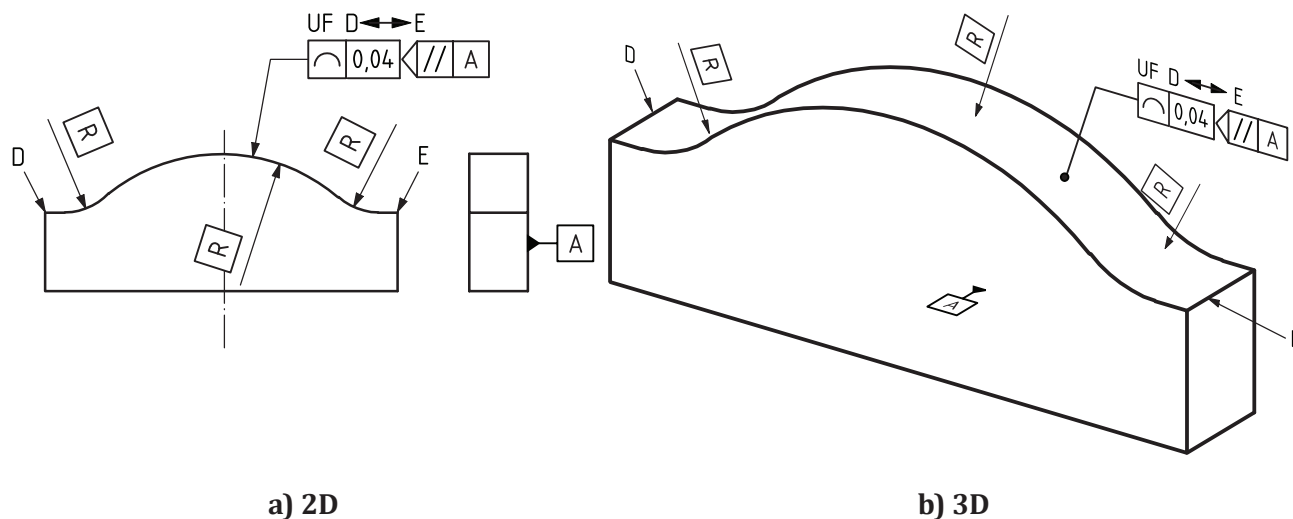


Figure 103 — Definition of the cylindricity tolerance zone

### 17.6 Line profile specification not related to a datum

The toleranced feature can be an integral feature or a derived feature. The nature of the nominal toleranced feature is explicitly given as a linear feature or a set of linear features. The shape of the nominal toleranced feature, except in the case of a straight line, shall be explicitly given by complete indications on the drawing or by queries of the CAD model, see ISO 16792.

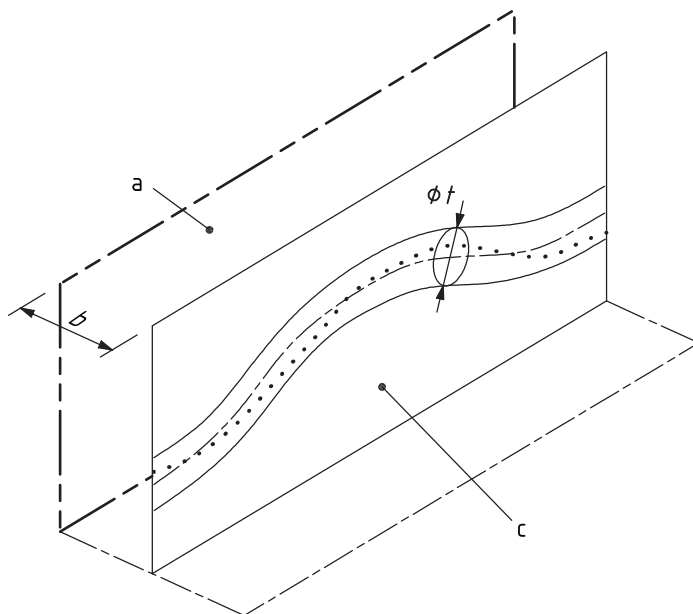
In [Figure 104](#), in each section, parallel to datum plane A, as specified by the intersection plane indicator, the extracted profile line shall be contained between two equidistant lines enveloping circles of diameter 0,04, the centres of which are situated on a line having the theoretically exact geometrical form. The UF specification element is used to indicate that the three circular sections in the compound feature shall be combined into one united feature. For deprecated 2D practice, see [A.2.1](#). For former practice regarding the extent of the toleranced feature, see [A.3.5](#).



NOTE Some of the TEDs necessary for an unambiguous definition of the nominal geometry are not shown.

**Figure 104 — Line profile indication**

The tolerance zone defined by the specification in [Figure 104](#) is limited by two lines enveloping circles of diameter  $t$ , the centres of which are situated on a line having the theoretically exact geometrical form, see [Figure 105](#).



- a Datum plane A.
- b Any distance.
- c Plane parallel to datum plane A.

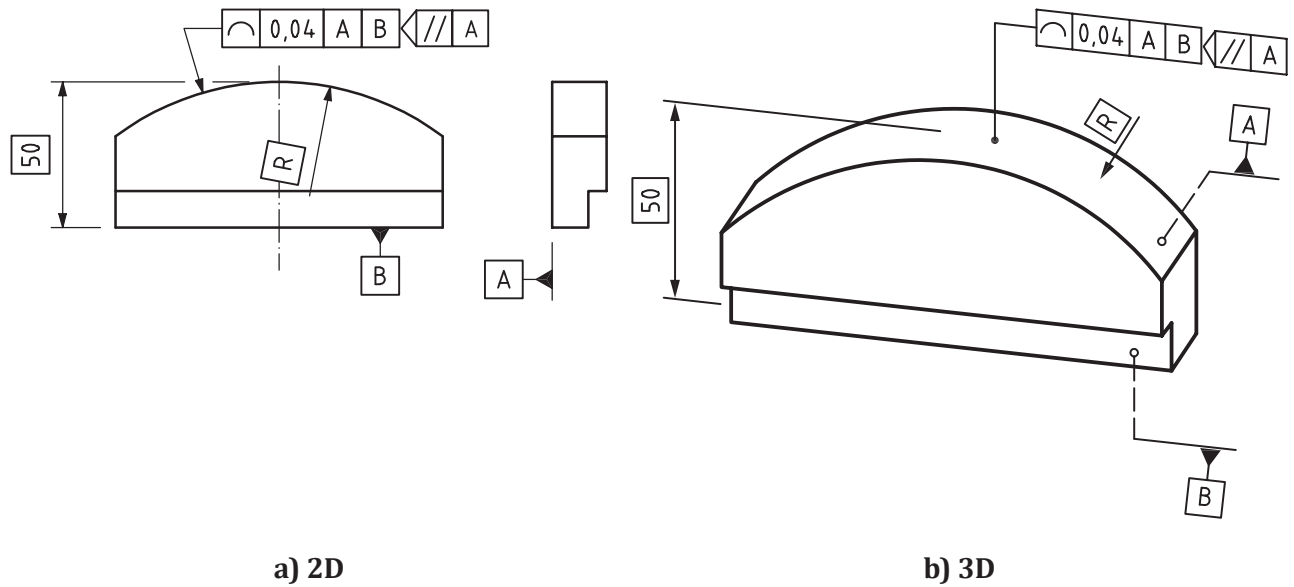
**Figure 105 — Definition of the line profile tolerance zone**

### 17.7 Line profile specification related to a datum system

The tolerated feature can be an integral feature or a derived feature. The nature of the nominal tolerated feature is explicitly given as a linear feature or a set of linear features. The shape of the

nominal toleranced feature, except in the case of a straight line, shall be explicitly given by complete indications on the drawing or by queries of the CAD model, see ISO 16792.

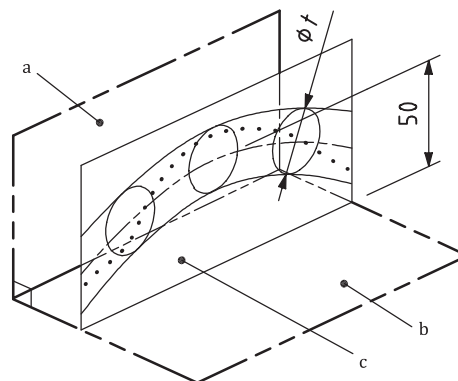
In [Figure 106](#), in each section, parallel to datum plane A, as specified by the intersection plane indicator, the extracted profile line shall be contained between two equidistant lines enveloping circles of diameter 0,04, the centres of which are situated on a line having the theoretically exact geometrical form with respect to datum plane A and datum plane B. For deprecated 2D practice, see [A.2.1](#).



NOTE Some of the TEDs necessary for an unambiguous definition of the nominal geometry are not shown.

**Figure 106 — Line profile indication**

The tolerance zone defined by the specification in [Figure 106](#) is limited by two lines enveloping circles of diameter  $t$ , the centres of which are situated on a line having the theoretically exact geometrical form with respect to datum plane A and datum plane B, see [Figure 107](#).



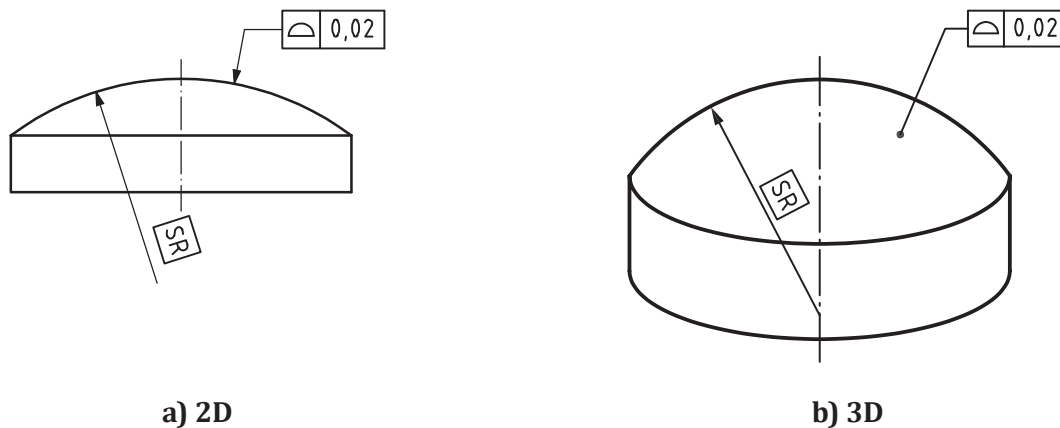
- a Datum A.
- b Datum B.
- c Plane parallel to datum A.

**Figure 107 — Definition of the line profile tolerance zone**

### 17.8 Surface profile specification not related to a datum

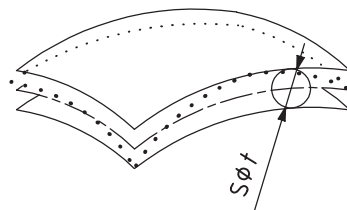
The tolerated feature can be an integral feature or a derived feature. The nature of the nominal tolerated feature is explicitly given as an areal feature. The shape of the nominal tolerated feature, except in the case of a flat surface, shall be explicitly given by complete indications on the drawing or by queries of the CAD model, see ISO 16792.

In [Figure 108](#), the extracted surface shall be contained between two equidistant surfaces enveloping spheres of diameter 0,02, the centres of which are situated on a surface having the theoretically exact geometrical form.



**Figure 108 — Surface profile indication**

The tolerance zone defined by the specification in [Figure 108](#) is limited by two surfaces enveloping spheres of diameter  $t$ , the centres of which are situated on a surface having the theoretically exact geometrical form, see [Figure 109](#).



**Figure 109 — Definition of the surface profile tolerance zone**

### 17.9 Surface profile specification related to a datum

The tolerated feature can be an integral feature or a derived feature. The nature of the nominal tolerated feature is explicitly given as an areal feature. The shape of the nominal tolerated feature, except in the case of a flat surface, shall be explicitly given by complete indications on the drawing or by queries of the CAD model, see ISO 16792.

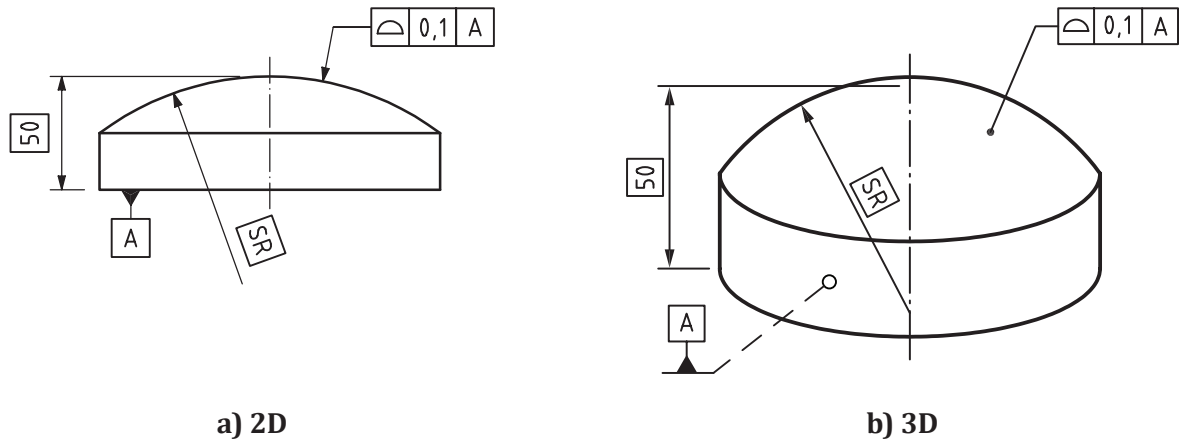
If the specification is an orientation specification, the  $\><$  specification element shall be placed in the second compartment of the tolerance indicator or after each datum indication in the tolerance indicator, or no datum that is able to lock a non-redundant translation of the tolerance zone shall be indicated. The angular dimensions that are locked between the nominal tolerated feature and the datums shall be defined by explicit or implicit TEDs or both, see ISO 5459.

If the specification is a location specification, at least one datum that locks a non-redundant translation of the tolerance zone shall be indicated in the tolerance indicator. The angular and linear dimensions



that are locked between the nominal toleranced feature and the datums shall be defined by explicit or implicit TEDs or both.

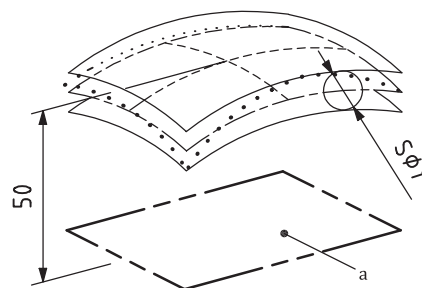
In [Figure 110](#), the extracted surface shall be contained between two equidistant surfaces enveloping spheres of diameter 0,1, the centres of which are situated on a surface having the theoretically exact geometrical form with respect to datum plane A.



NOTE Some of the TEDs necessary for an unambiguous definition of the nominal geometry are not shown.

**Figure 110 — Surface profile indication**

The tolerance zone defined by the specification in [Figure 110](#) is limited by two surfaces enveloping spheres of diameter  $t$ , the centres of which are situated on a surface having the theoretically exact geometrical form with respect to datum plane A, see [Figure 111](#).



a Datum A.

**Figure 111 — Definition of the surface profile tolerance zone**

## 17.10 Parallelism specification

### 17.10.1 General

The toleranced feature can be an integral feature or a derived feature. The nature of the nominal toleranced feature is a linear feature, a set of linear features, or an areal feature. The shape of each nominal toleranced feature is explicitly given as a straight line or a flat surface. If the indicated feature is a nominally flat surface and the toleranced feature is a set of straight lines in that surface, an intersection plane indicator shall be indicated. The TED angles that are locked between the nominal toleranced feature and the datums shall be defined by implicit TEDs ( $0^\circ$ ).

17.10.2 Parallelism specification of a median line related to a datum system

In [Figure 112](#), the extracted median line shall be contained between two parallel planes 0,1 apart which are parallel to datum axis A. The planes limiting the tolerance zone are parallel to datum plane B as specified by the orientation plane indicator. Datum B is secondary to datum A. For former practice, see [A.3.6](#).

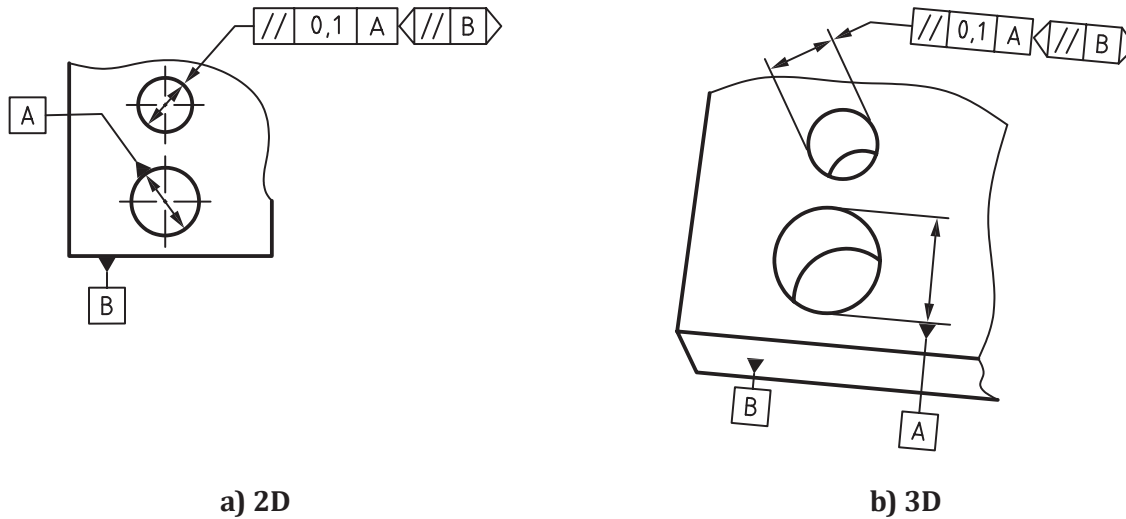
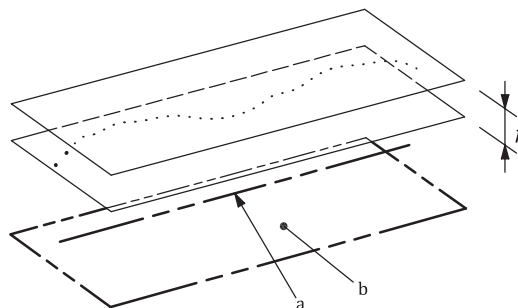


Figure 112 — Parallelism indication

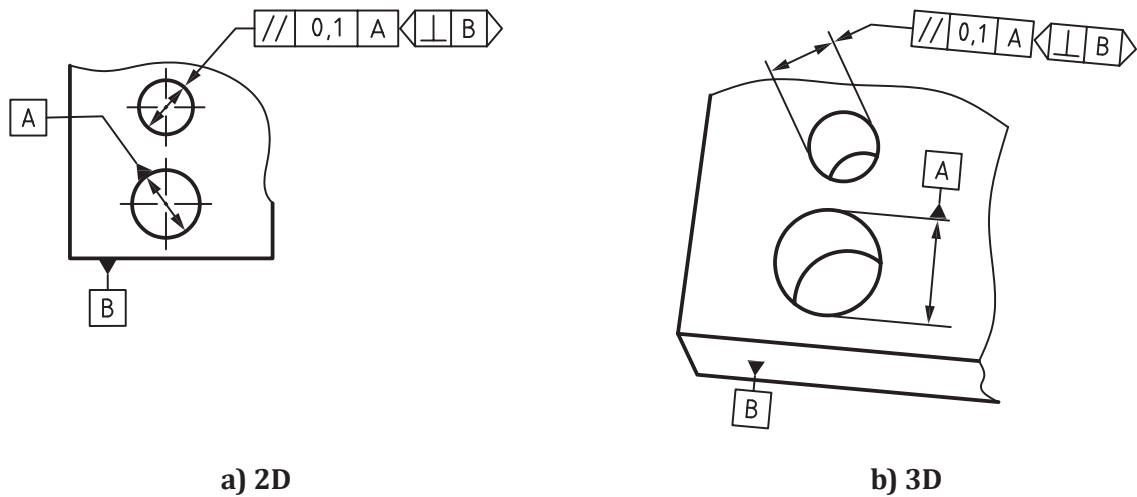
The tolerance zone defined by the specification in [Figure 112](#) is limited by two parallel planes a distance  $t$  apart. The planes are parallel to the datums and in the direction specified, see [Figure 113](#).



- a Datum A.
- b Datum B.

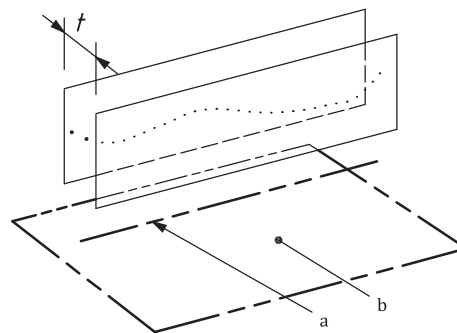
Figure 113 — Definition of the parallelism tolerance zone

In [Figure 114](#), the extracted median line shall be contained between two parallel planes 0,1 apart, which are parallel to datum axis A. The planes limiting the tolerance zone are perpendicular to datum plane B as specified by the orientation plane indicator. Datum B is secondary to datum A, see [14.4](#). For former practice, see [A.3.6](#).



**Figure 114 — Parallelism indication**

The tolerance zone defined by the specification in [Figure 114](#) is limited by two parallel planes a distance  $t$  apart. The planes are parallel to datum A and perpendicular to datum B, see [Figure 115](#).



- a Datum A.
- b Datum B.

**Figure 115 — Definition of the parallelism tolerance zone**

In [Figure 116](#), the extracted median line shall be contained between two pairs of parallel planes, which are parallel to datum axis A, and positioned 0,1 and 0,2 apart respectively. The orientation of the planes limiting the tolerance zones is specified with respect to datum plane B by the orientation plane indicators. Datum B is secondary to datum A, see [14.4](#). For former practice, see [A.3.6](#).

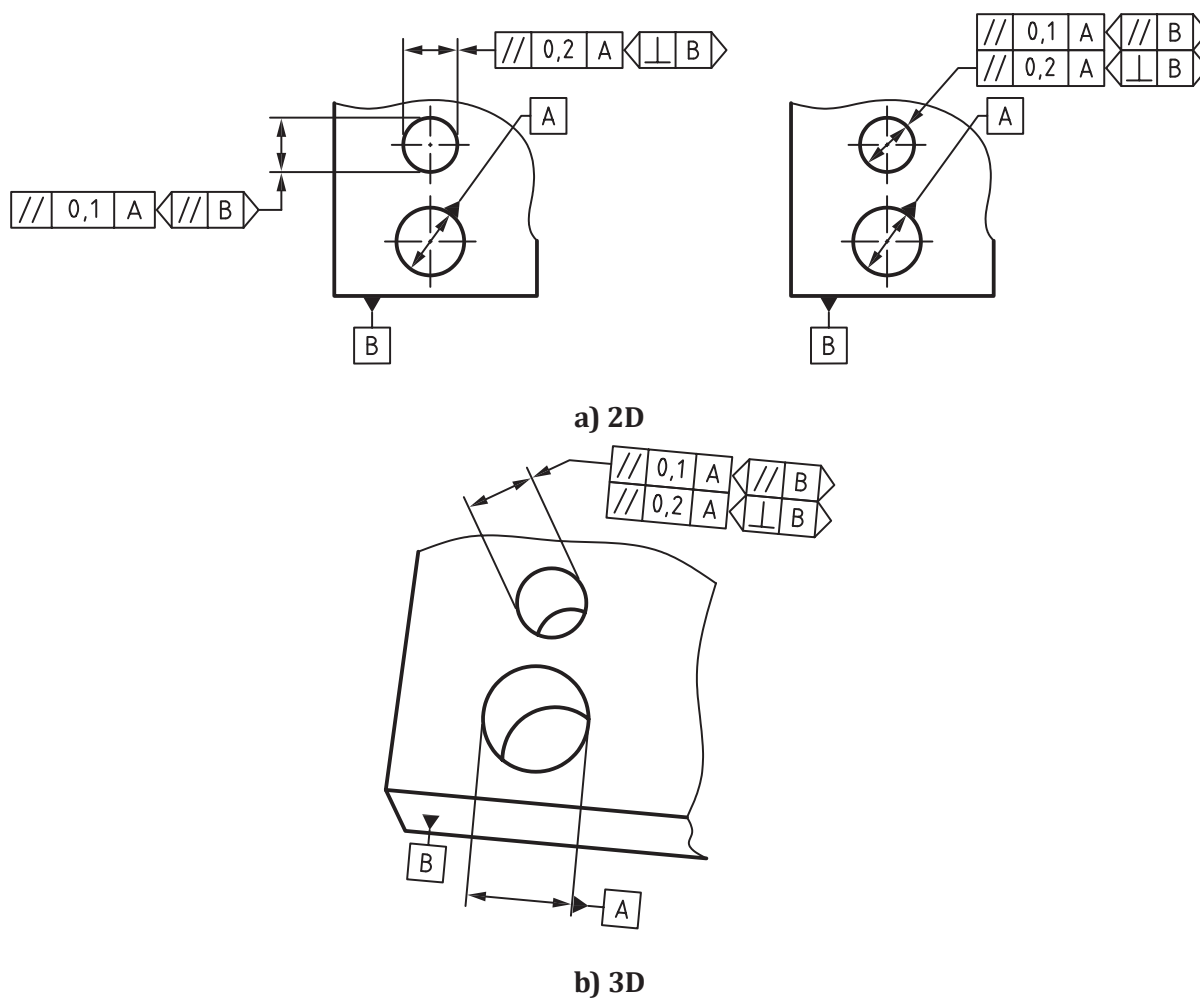
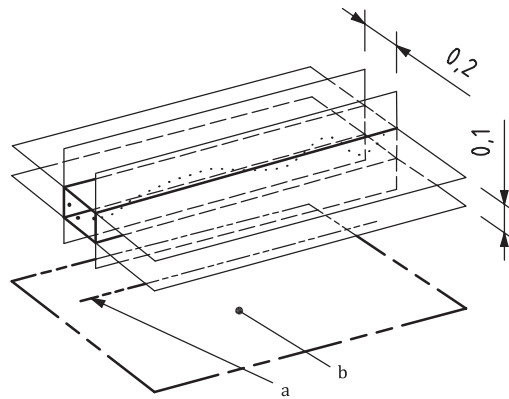


Figure 116 — Parallelism indication

Based on the specification in [Figure 116](#), the extracted median line shall be contained between two pairs of parallel planes, which are parallel to the datum axis A, and positioned 0,1 and 0,2 apart respectively, see [Figure 117](#). The orientations of the tolerance zones are specified with respect to datum plane B by the orientation plane indicators:

- the planes limiting the tolerance zone of 0,2 are perpendicular to the orientation plane B as specified by the orientation plane indicator;
- the planes limiting the tolerance zone of 0,1 are parallel to the orientation plane B as specified by the orientation plane indicator.

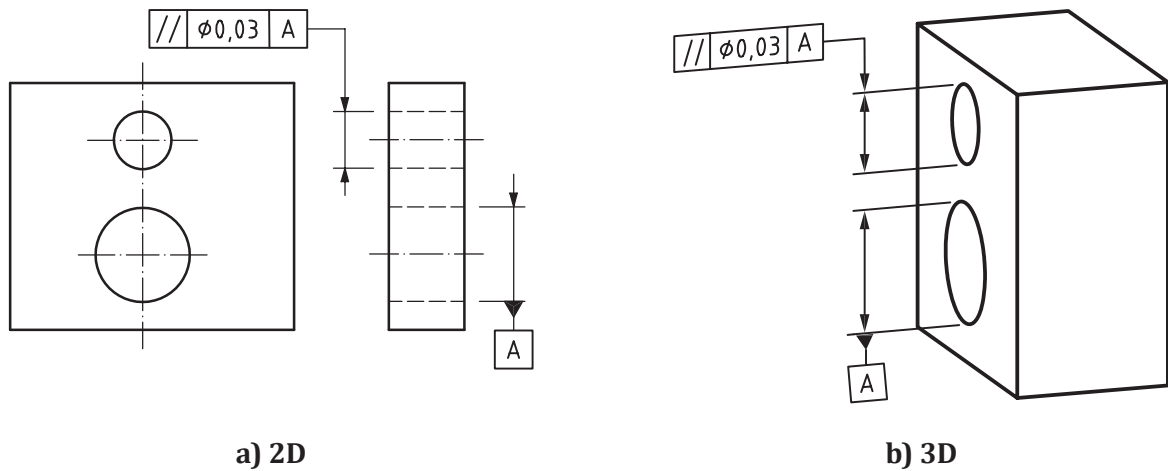


- a Datum A.
- b Datum B.

**Figure 117 — Definition of the parallelism tolerance zones**

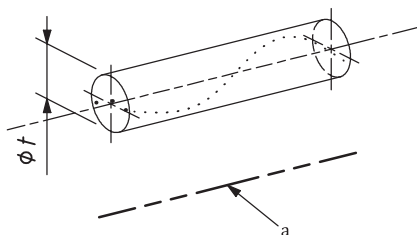
**17.10.3 Parallelism specification of a median line related to a datum straight line**

In [Figure 118](#), the extracted median line shall be within a cylindrical zone of diameter 0,03, parallel to datum axis A.



**Figure 118 — Parallelism indication**

The tolerance zone defined by the specification in [Figure 118](#) is limited by a cylinder of diameter  $t$ , parallel to the datum, because the tolerance value is preceded by the symbol  $\varnothing$ , see [Figure 119](#).

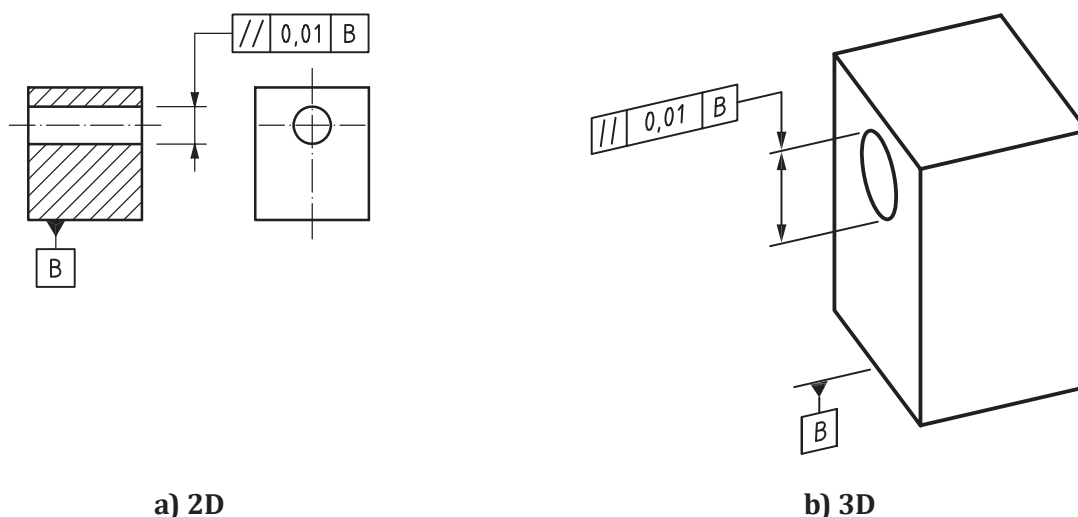


a Datum A.

Figure 119 — Definition of the parallelism tolerance zone

#### 17.10.4 Parallelism specification of a median line related to a datum plane

In [Figure 120](#), the extracted median line shall be contained between two parallel planes 0,01 apart, which are parallel to datum plane B.

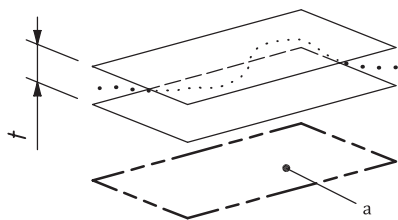


a) 2D

b) 3D

Figure 120 — Parallelism indication

The tolerance zone defined by the specification in [Figure 120](#) is limited by two parallel planes a distance  $t$  apart and parallel to the datum, see [Figure 121](#).



a Datum B.

Figure 121 — Definition of the parallelism tolerance zone

### 17.10.5 Parallelism specification of a set of lines in a surface related to a datum plane

In [Figure 122](#), each extracted line, parallel to datum plane B as specified by the intersection plane indicator, shall be contained between two parallel lines 0,02 apart, which are parallel to datum plane A. Datum B is a primary datum, see [14.4](#). For deprecated 2D practice, see [A.2.2](#).

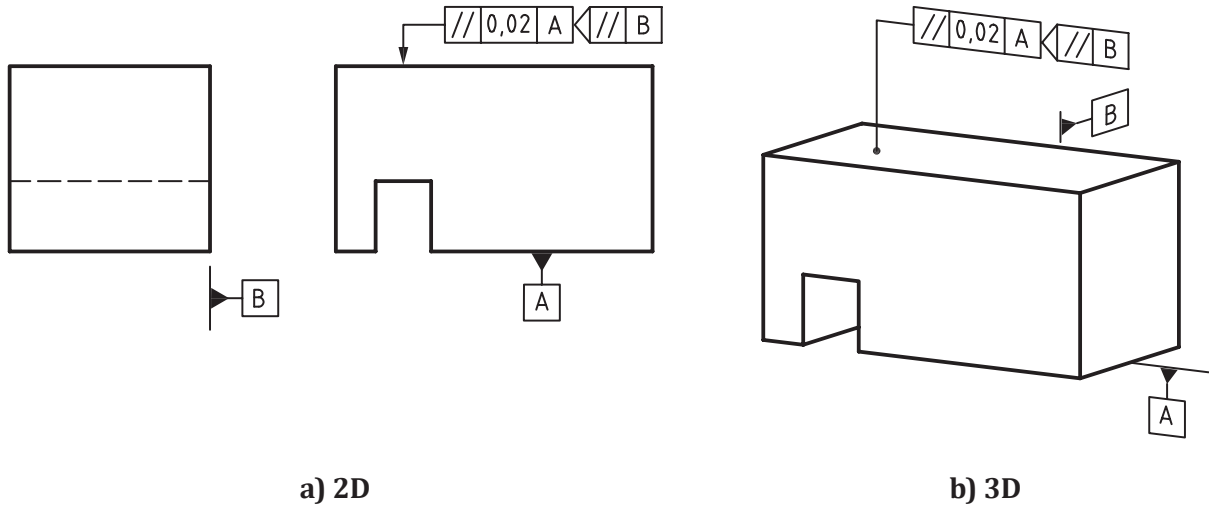
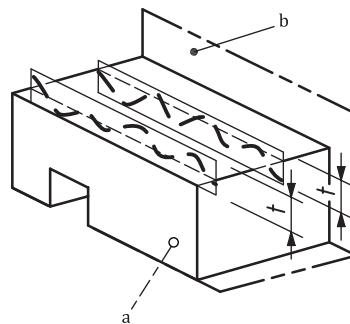


Figure 122 — Parallelism indication

The tolerance zone defined by the specification in [Figure 122](#) is limited by two parallel lines a distance  $t$  apart and oriented parallel to datum plane A, the lines lying in a plane parallel to datum plane B, see [Figure 123](#).

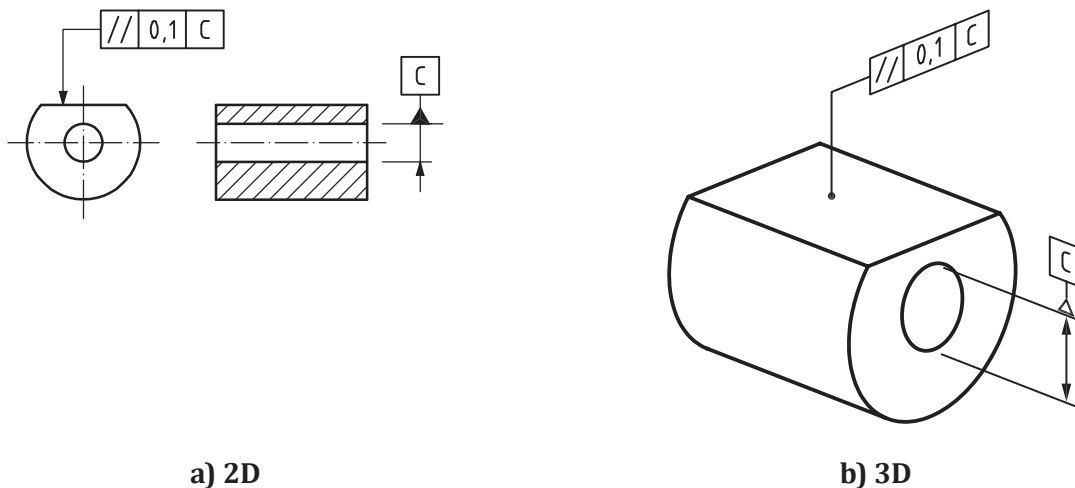


- a Datum A.
- b Datum B.

Figure 123 — Definition of the parallelism tolerance zone

### 17.10.6 Parallelism specification of a planar surface related to a datum straight line

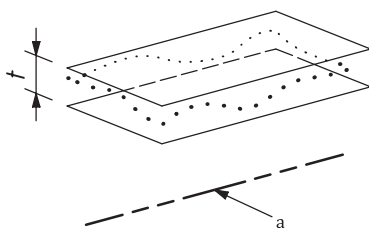
In [Figure 124](#), the extracted surface shall be contained between two parallel planes 0,1 apart, which are parallel to datum axis C.



**Figure 124 — Parallelism indication**

**NOTE** The rotation of the tolerance zone around the datum axis is not defined with the indication given in [Figure 124](#), only the direction is specified.

The tolerance zone defined by the specification in [Figure 124](#) is limited by two parallel planes a distance  $t$  apart and parallel to the datum, see [Figure 125](#).



a Datum C.

**Figure 125 — Definition of the parallelism tolerance zone**

### 17.10.7 Parallelism specification of a planar surface related to a datum plane

In [Figure 126](#), the extracted surface shall be contained between two parallel planes 0,01 apart, which are parallel to datum plane D.



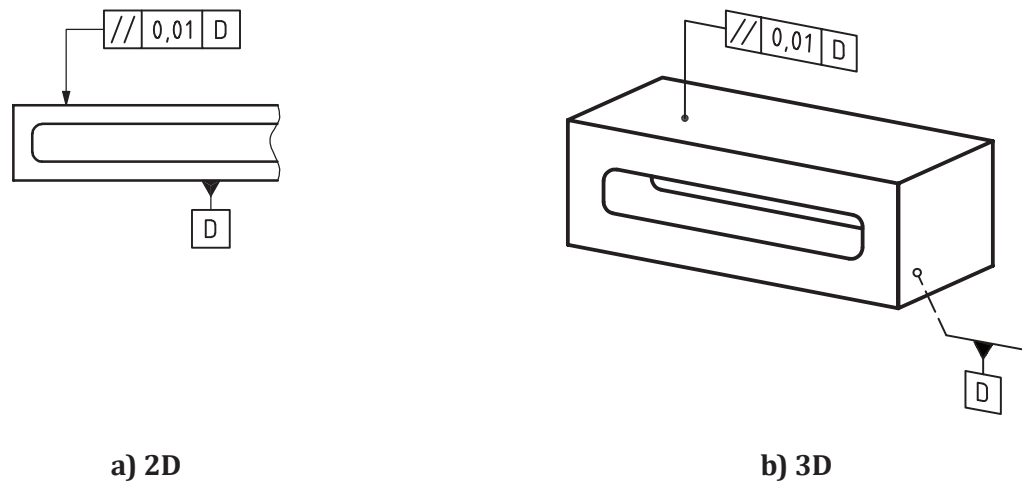
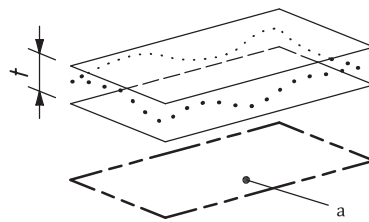


Figure 126 — Parallelism indication

The tolerance zone defined by the specification in Figure 126 is limited by two parallel planes a distance  $t$  apart and parallel to the datum plane, see Figure 127.



a Datum D.

Figure 127 — Definition of the parallelism tolerance zone

## 17.11 Perpendicularity specification

### 17.11.1 General

The toleranced feature can be an integral feature or a derived feature. The nature of the nominal toleranced feature is a linear feature, a set of linear features, or an areal feature. The shape of each nominal toleranced feature is explicitly given as a straight line or a flat surface. If the indicated feature is a nominally flat surface and the toleranced feature is a set of straight lines in that surface, an intersection plane indicator shall be indicated. The TED angles that are locked between the nominal toleranced feature and the datums shall be defined by implicit TEDs ( $90^\circ$ ).

### 17.11.2 Perpendicularity specification of a median line related to a datum straight line

In Figure 128, the extracted median line shall be contained between two parallel planes 0,06 apart, which are perpendicular to datum axis A.

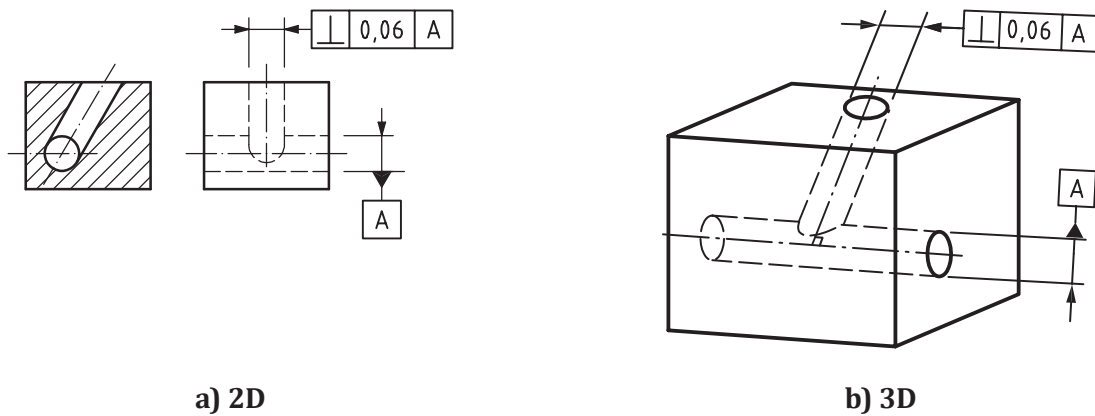
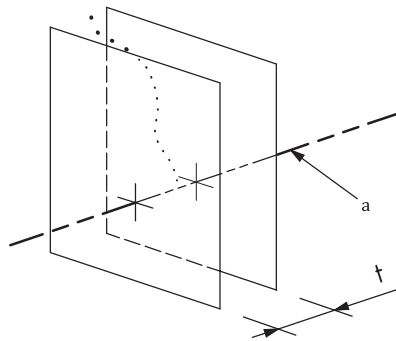


Figure 128 — Perpendicularity indication

The tolerance zone defined by the specification in [Figure 128](#) is limited by two parallel planes a distance  $t$  apart and perpendicular to the datum axis, see [Figure 129](#).



a Datum A.

Figure 129 — Definition of the perpendicularity tolerance zone

### 17.11.3 Perpendicularity specification of a median line related to a datum system

In [Figure 130](#), the extracted median line of the cylinder shall be contained between two parallel planes 0,1 apart, which are perpendicular to datum plane A and in the orientation specified with respect to datum plane B. Datum B is secondary to datum A, see [14.4](#). For former practice, see [A.3.6](#).

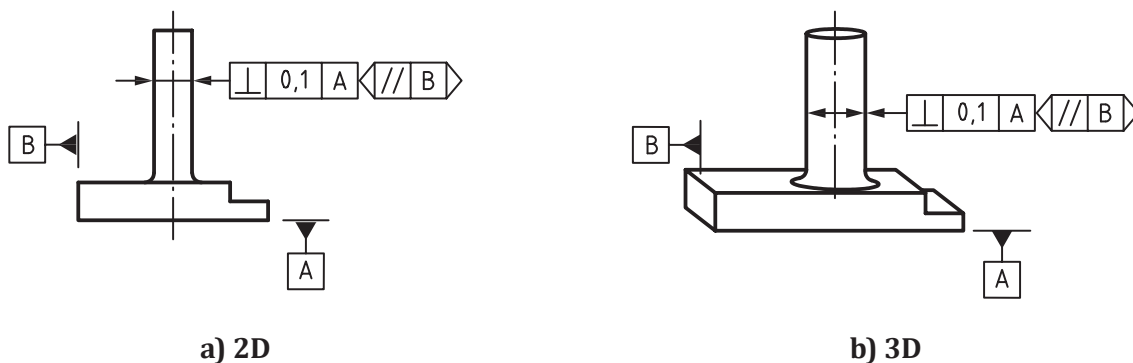
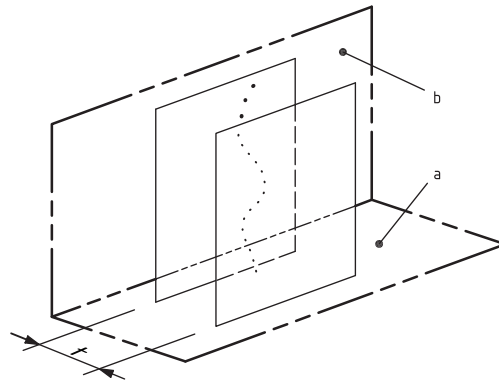


Figure 130 — Perpendicularity indication

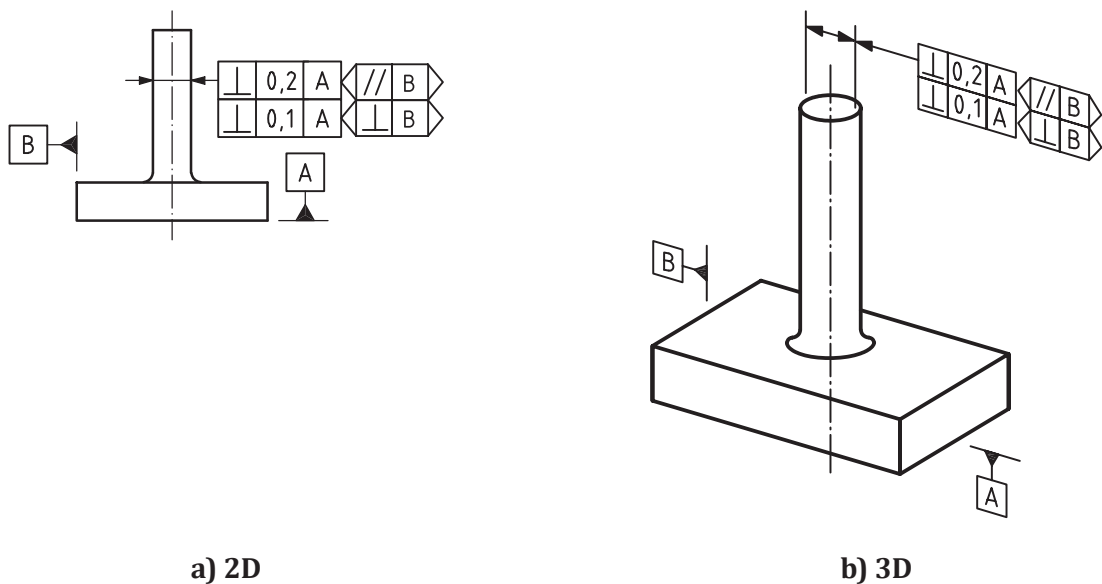
The tolerance zone defined by the specification in [Figure 130](#) is limited by two parallel planes a distance  $t$  apart. The planes are perpendicular to datum A and parallel to secondary datum B, see [Figure 131](#).



- a Datum A.
- b Datum B.

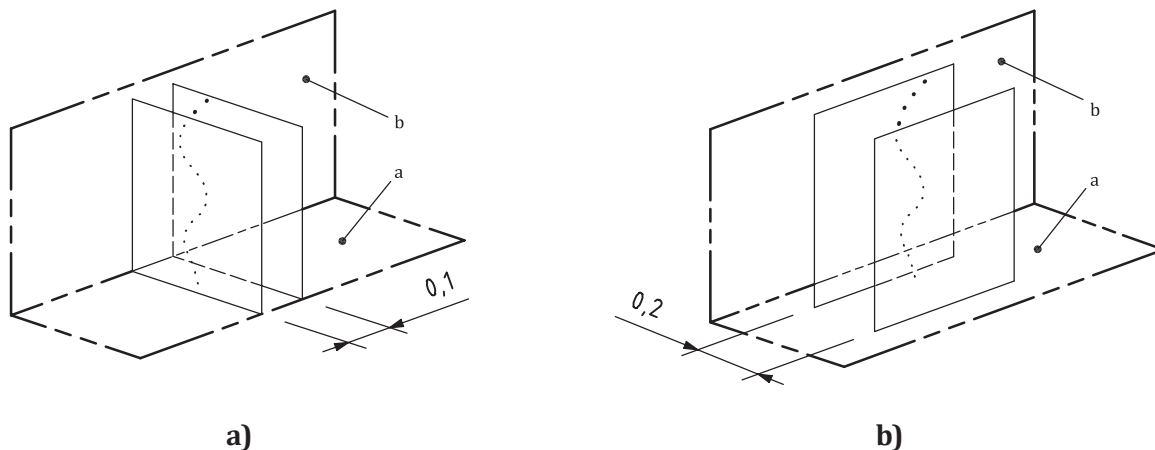
**Figure 131 — Definition of the perpendicularity tolerance zone**

In [Figure 132](#), the extracted median line of the cylinder shall be contained between two pairs of parallel planes, perpendicular to datum plane A, and positioned 0,1 and 0,2 apart respectively. The orientation of the planes limiting the tolerance zones is specified with respect to datum plane B by the orientation plane indicators. Datum B is secondary to datum A, see [14.4](#). For former practice, see [A.3.6](#).



**Figure 132 — Perpendicularity indication**

The tolerance zone defined by the specification in [Figure 132](#) is limited by two pairs of parallel planes a distance 0,1 and 0,2 apart and perpendicular to each other. Both planes are perpendicular to the datum A. One pair of planes is perpendicular to datum B, see [Figure 133a](#)), the other is parallel to datum B, see [Figure 133 b](#)).

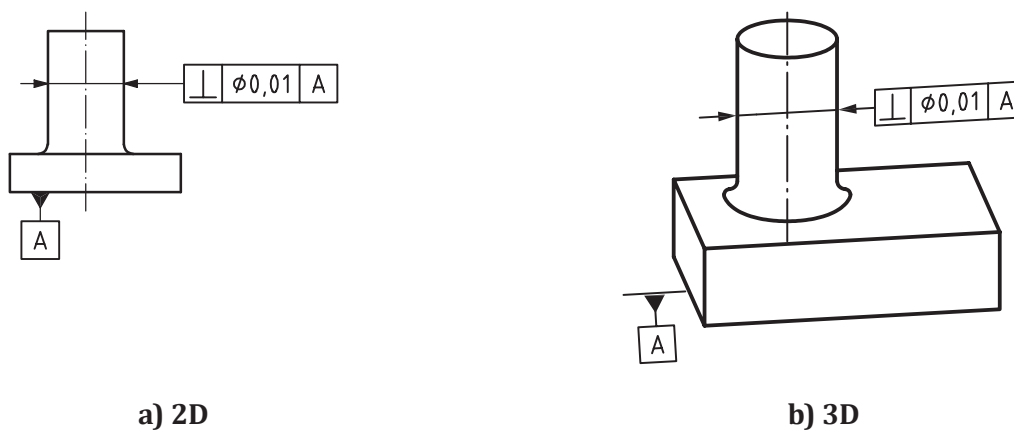


- a Datum A.
- b Datum B.

**Figure 133 — Definition of the perpendicularity tolerance zones**

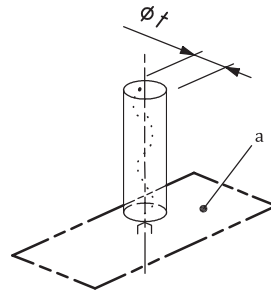
**17.11.4 Perpendicularity specification of a median line related to a datum plane**

In [Figure 134](#), the extracted median line of the cylinder shall be within a cylindrical zone of diameter 0,01, which is perpendicular to datum plane A.



**Figure 134 — Perpendicularity indication**

The tolerance zone defined by the specification in [Figure 134](#) is limited by a cylinder of diameter  $t$  perpendicular to the datum, because the tolerance value is preceded by the symbol  $\varnothing$ , see [Figure 135](#).



a Datum A.

Figure 135 — Definition of the perpendicularity tolerance zone

### 17.11.5 Perpendicularity specification of a planar surface related to a datum straight line

In Figure 136, the extracted surface shall be contained between two parallel planes 0,08 apart, which are perpendicular to datum axis A.

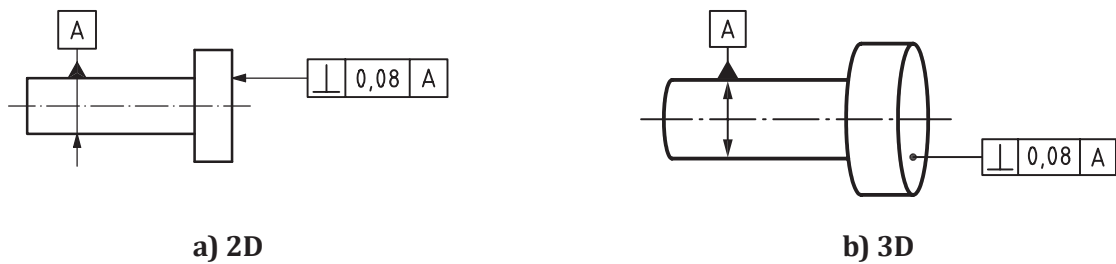
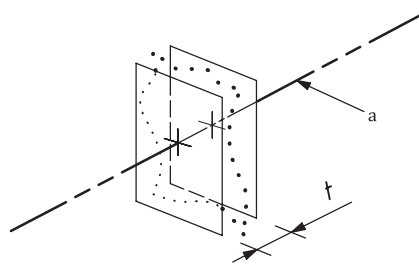


Figure 136 — Perpendicularity indication

The tolerance zone defined by the specification in Figure 136 is limited by two parallel planes a distance  $t$  apart and perpendicular to the datum, see Figure 137.

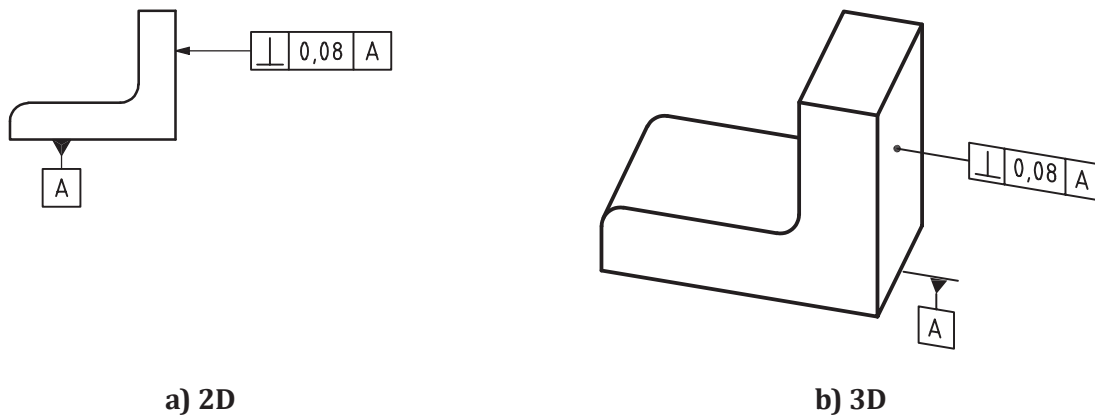


a Datum A.

Figure 137 — Definition of the perpendicularity tolerance zone

### 17.11.6 Perpendicularity specification of a planar surface related to a datum plane

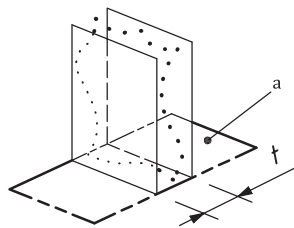
In Figure 138, the extracted surface shall be contained between two parallel planes 0,08 apart, which are perpendicular to datum plane A.



**Figure 138 — Perpendicularity indication**

**NOTE** The rotation of the tolerance zone around the normal of the datum plane is not defined with the indication given in [Figure 138](#), only the direction is specified.

The tolerance zone defined by the specification in [Figure 138](#) is limited by two parallel planes a distance  $t$  apart and perpendicular to the datum, see [Figure 139](#).



a Datum A.

**Figure 139 — Definition of the perpendicularity tolerance zone**

## 17.12 Angularity specification

### 17.12.1 General

The tolerated feature can be an integral feature or a derived feature. The nature of the nominal tolerated feature is a linear feature, a set of linear features or an areal feature. The shape of each nominal tolerated feature is explicitly given as a straight line or a flat surface. If the indicated feature is a nominally flat surface and the tolerated feature is a set of straight lines in that surface, an intersection plane indicator shall be indicated. The TED angles that are locked between the nominal tolerated feature and the datums shall be defined by at least one explicit TED. Additional angles may be defined by implicit TEDs ( $0^\circ$  or  $90^\circ$ ).

### 17.12.2 Angularity specification of a median line related to a datum straight line

In [Figure 140](#), the extracted median line shall be contained between two parallel planes 0,08 apart that are inclined at a theoretically exact angle of  $60^\circ$  to the common datum straight line A-B.

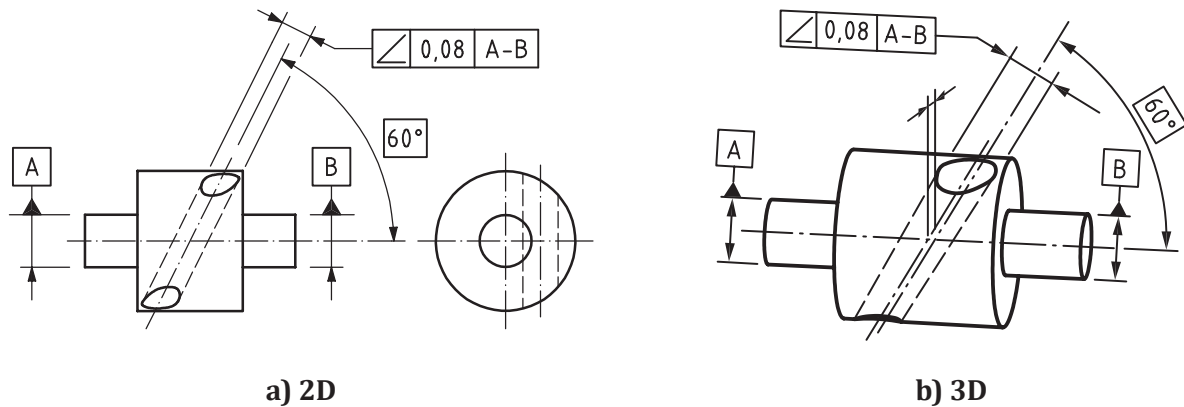
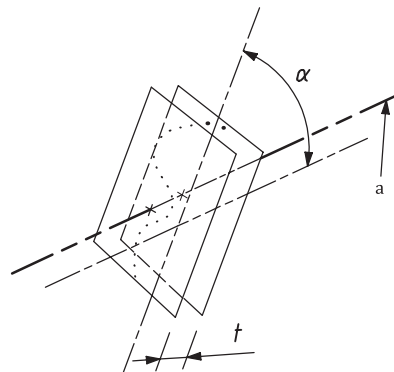


Figure 140 — Angularity indication

NOTE 1 The rotation of the tolerance zone around the datum axis is not defined with the indication given in [Figure 140](#), only the direction is specified.

NOTE 2 The distance from the tolerance zone to common datum A-B is not constrained.

The tolerance zone defined by the specification in [Figure 140](#) is limited by two parallel planes a distance  $t$  apart and inclined at the specified angle to the datum. The considered line and the datum line are not in the same plane see [Figure 141](#).



a Common datum A-B.

Figure 141 — Definition of the angularity tolerance zone

In [Figure 142](#), the extracted median line shall be contained within a cylinder of diameter 0,08, which is inclined at a theoretically exact angle of 60° to the common datum straight line A-B.

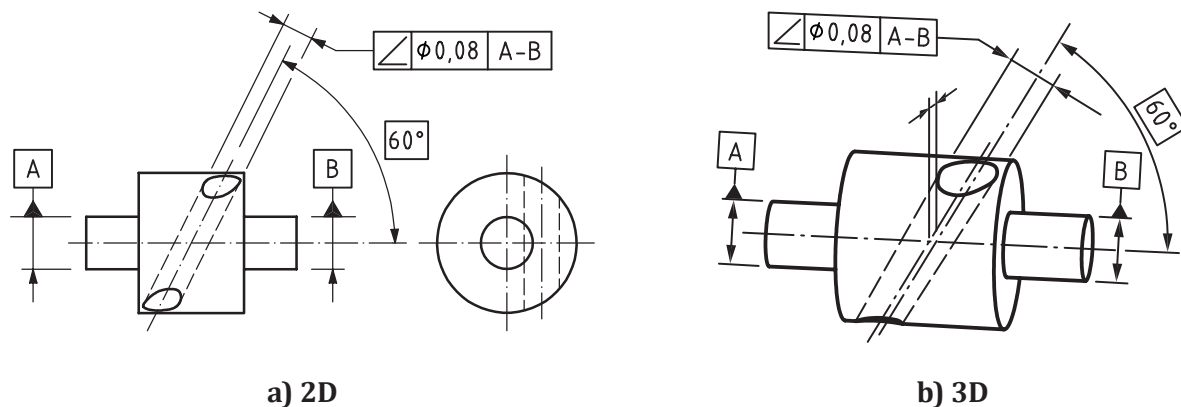
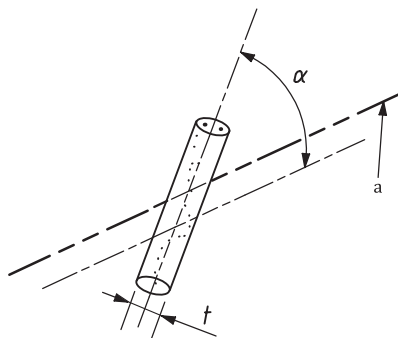


Figure 142 — Angularity

The tolerance zone defined by the specification in [Figure 142](#) is limited by a cylinder of diameter  $t$  inclined at the specified angle to the datum. The considered line and the datum line are not in the same plane, see [Figure 143](#).



a Common datum A-B.

NOTE The distance from the tolerance zone to common datum A-B is not constrained.

Figure 143 — Definition of the angularity tolerance zone

### 17.12.3 Angularity specification for a median line related to a datum system

In [Figure 144](#), the extracted median line shall be within a cylindrical tolerance zone of diameter 0,1 that is parallel to datum plane B and inclined at a theoretically exact angle of 60° to datum plane A.



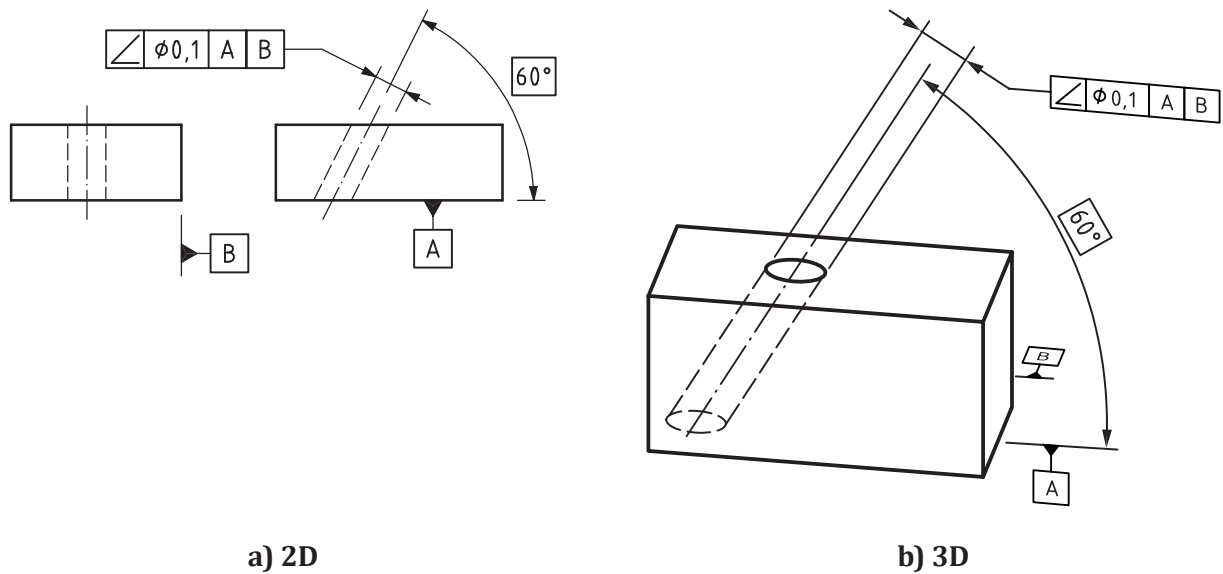
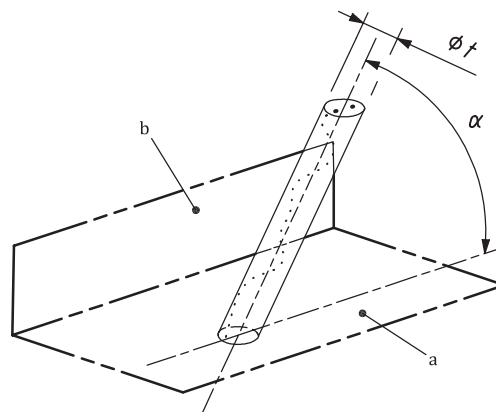


Figure 144 — Angularity indication

The tolerance zone defined by the specification in Figure 144 is limited by a cylinder of diameter  $t$ , because the tolerance value is preceded by the symbol  $\varnothing$ . The cylindrical tolerance zone is parallel to a datum plane B and inclined at the specified angle to datum plane A, see Figure 145.



- a Datum A.
- b Datum B.

Figure 145 — Definition of the angularity tolerance zone

#### 17.12.4 Angularity specification for a planar surface related to a datum straight line

In Figure 146, the extracted surface shall be contained between two parallel planes 0,1 apart that are inclined at a theoretically exact angle of  $75^\circ$  to datum axis A.

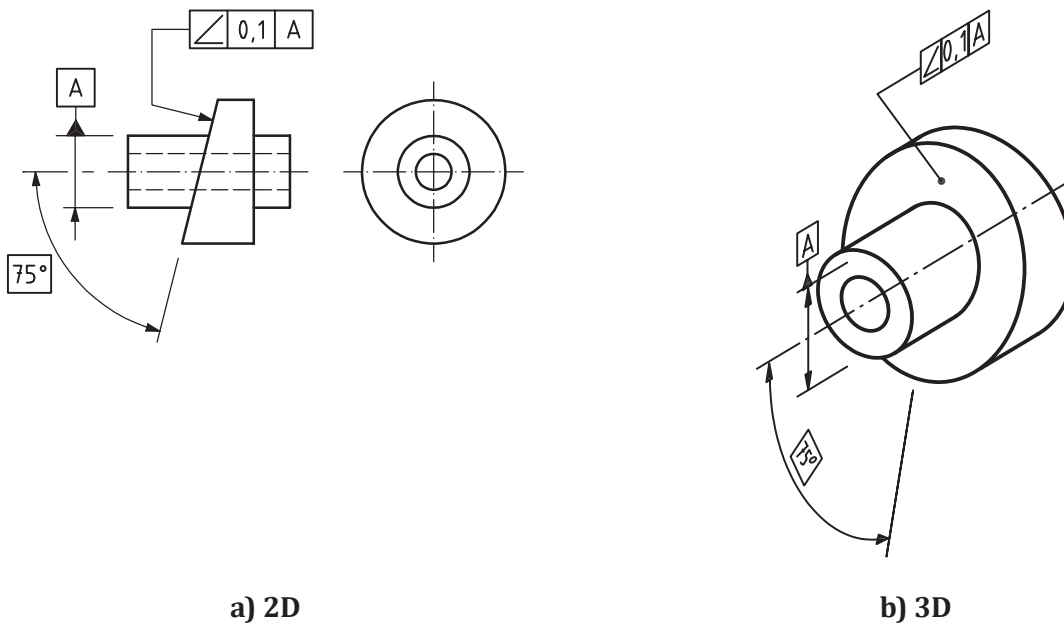
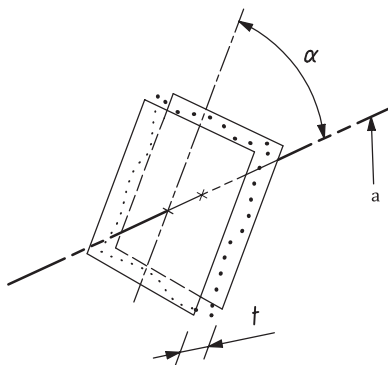


Figure 146 — Angularity indication

NOTE The rotation of the tolerance zone around the datum axis is not defined with the indication given in Figure 146, only the direction is specified.

The tolerance zone defined by the specification in Figure 146 is limited by two parallel planes a distance  $t$  apart and inclined at the specified angle to the datum, see Figure 147.



a Datum A.

Figure 147 — Definition of the angularity tolerance zone

### 17.12.5 Angularity specification for a planar surface related to a datum plane

In Figure 148, the extracted surface shall be contained between two parallel planes 0,08 apart that are inclined at a theoretically exact angle of 40° to datum plane A.

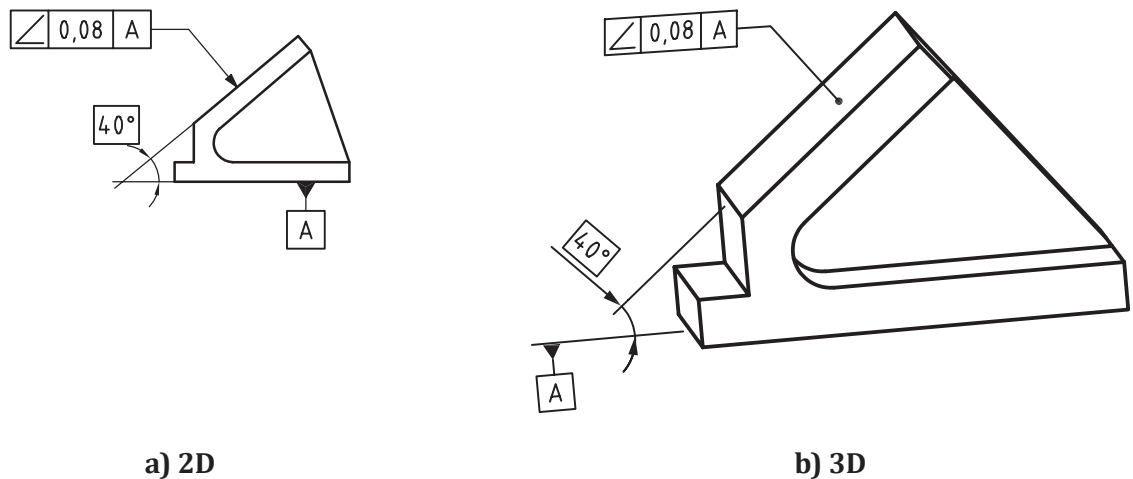
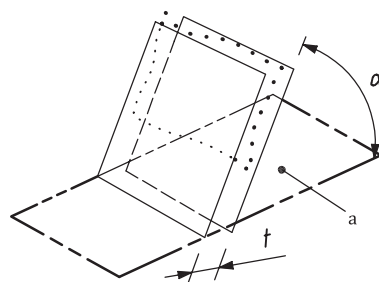


Figure 148 — Angularity indication

NOTE The rotation of the tolerance zone around the normal to the datum plane is not defined with the indication given in Figure 148, only the direction is specified.

The tolerance zone defined by the specification in Figure 148 is limited by two parallel planes a distance  $t$  apart and inclined at the specified angle to the datum, see Figure 149.



a Datum A.

Figure 149 — Definition of the angularity tolerance zone

## 17.13 Position specification

### 17.13.1 General

The toleranced feature is either an integral feature or a derived feature. The nature and shape of the nominal toleranced feature is an integral or derived point, straight line or flat surface, a non-straight derived line or a non-flat derived surface, see also ISO 1660. The shape of the nominal toleranced feature, except in the case of a straight line or a flat surface, shall be explicitly given by complete indications on the drawing or by queries of the CAD model, see ISO 16792.

### 17.13.2 Position specification of a derived point

In Figure 150, the extracted centre of the sphere shall be within a spherical zone of diameter 0,3, the centre of which coincides with the theoretically exact position of the sphere, with respect to datum planes A and B and to datum median plane C.

NOTE The definition of extracted centre of a sphere has not been standardized.

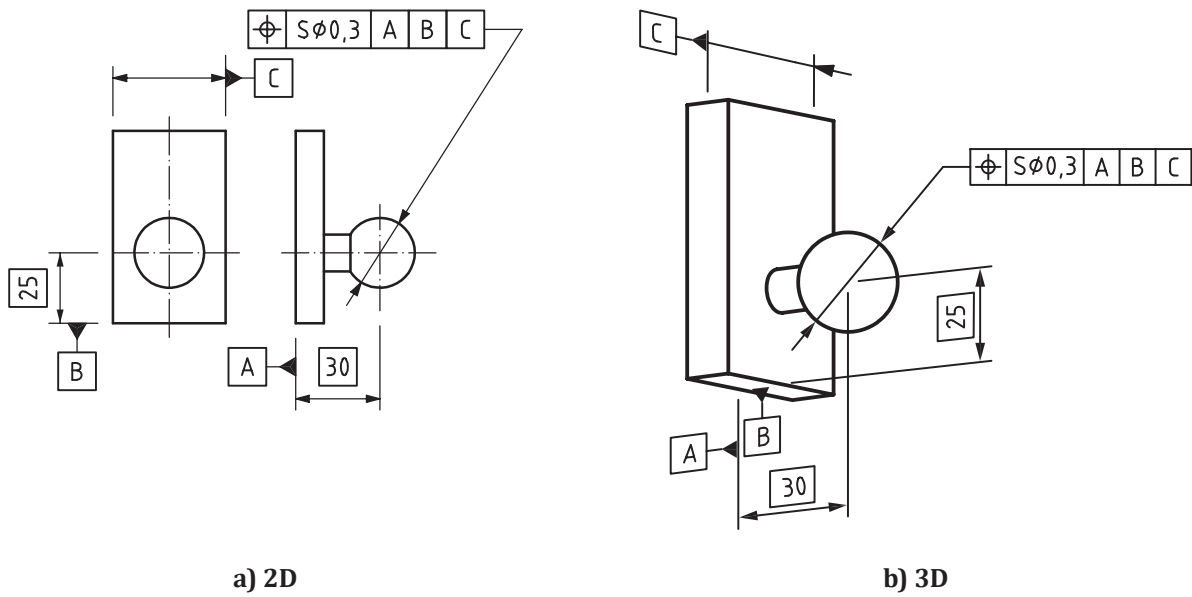
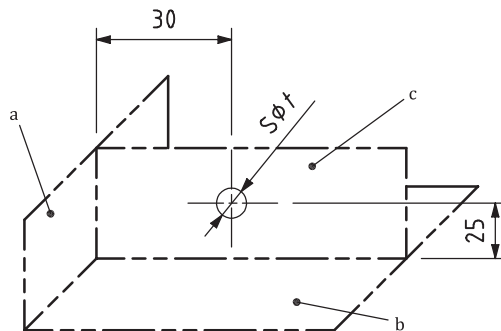


Figure 150 — Position indication

The tolerance zone defined by the specification in [Figure 150](#) is limited by a sphere of diameter 0,3 because the tolerance value is preceded by the symbol  $S\phi$ . The centre of the spherical tolerance zone is fixed by theoretically exact dimensions with respect to datums A, B and C, see [Figure 151](#).



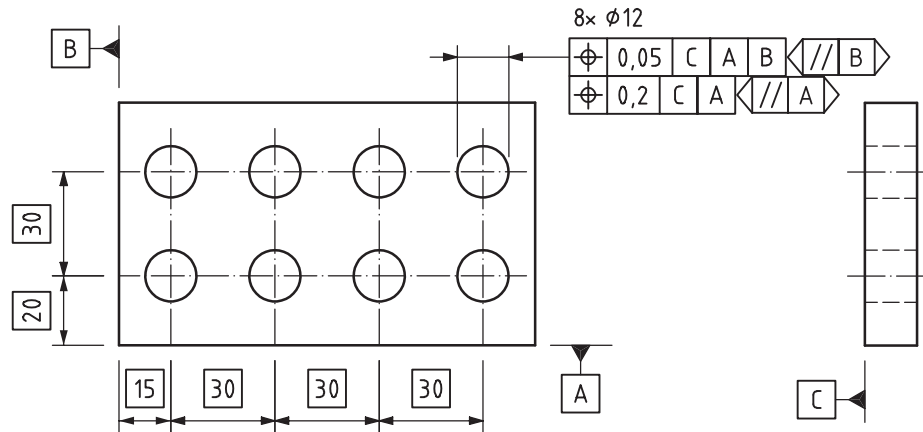
- a Datum A.
- b Datum B.
- c Datum C.

Figure 151 — Definition of the position tolerance zone

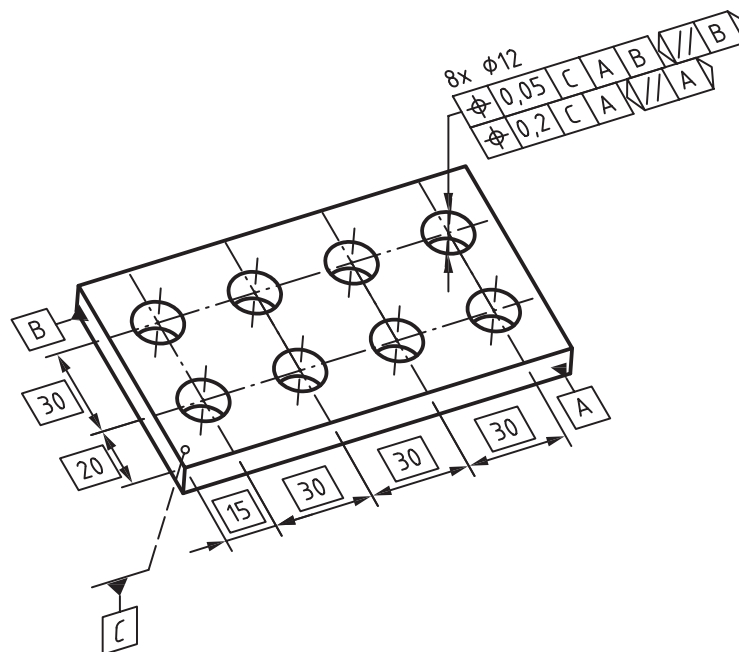
### 17.13.3 Position specification of a median line

In [Figure 152](#), the extracted median line of each hole shall be contained between two pairs of parallel planes, positioned 0,05 and 0,2 apart respectively, in the direction specified, and perpendicular to each other. Each pair of parallel planes is orientated with respect to the datum system and symmetrically disposed about the theoretically exact position of the considered hole, with respect to datum planes C, A and B.

For deprecated practice, see [A.2.4](#).



a) 2D

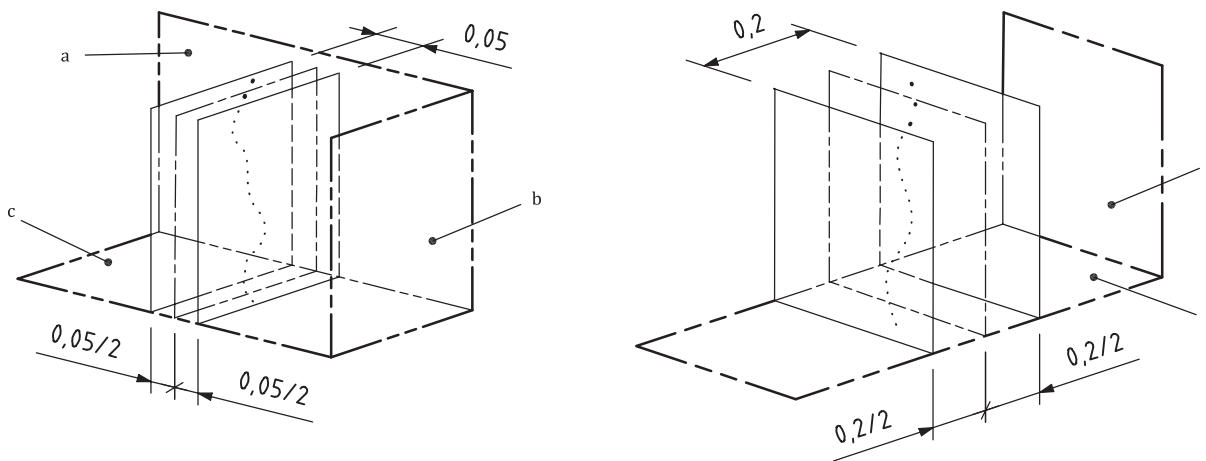


b) 3D

NOTE Instead of using orientation plane indicators, similar requirements can often be indicated using the orientation only modifier, see ISO 5459. In this figure, the two orientation plane indicators could be omitted and the datum system |C|A|B| could be replaced by |C|A><|B| for an identical meaning.

Figure 152 — Position indication

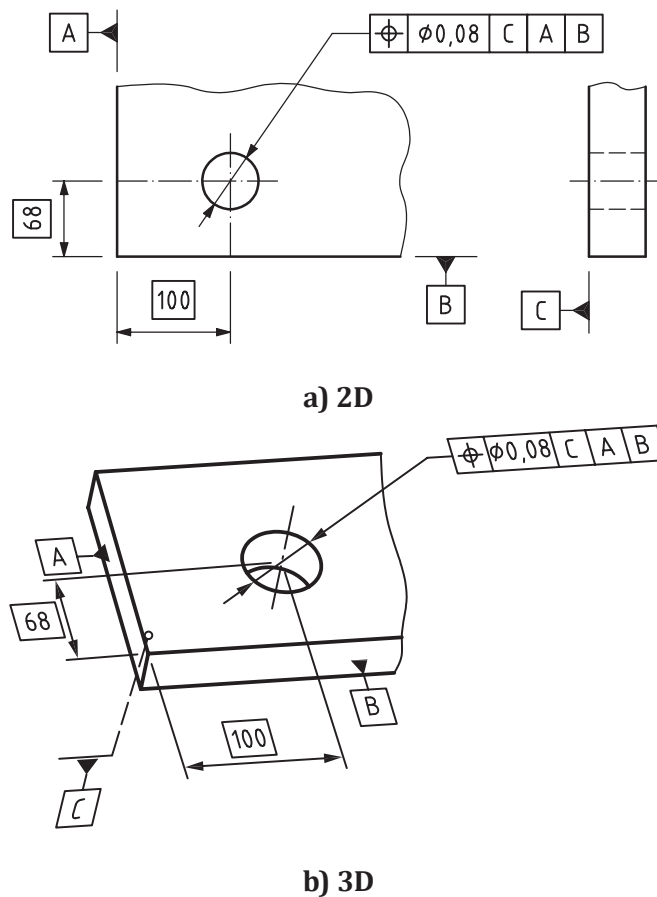
The tolerance zone defined by the specification in Figure 152 is limited by two pairs of parallel planes a distance 0,05 and 0,2 apart respectively and symmetrically disposed about the theoretically exact position. The theoretically exact position is fixed by theoretically exact dimensions with respect to datums C, A and B. The specification applies in two directions with respect to the datums, see Figure 153.



- a Secondary datum A, perpendicular to datum C.
- b Tertiary datum B, perpendicular to datum C and secondary datum A.
- c Datum C.

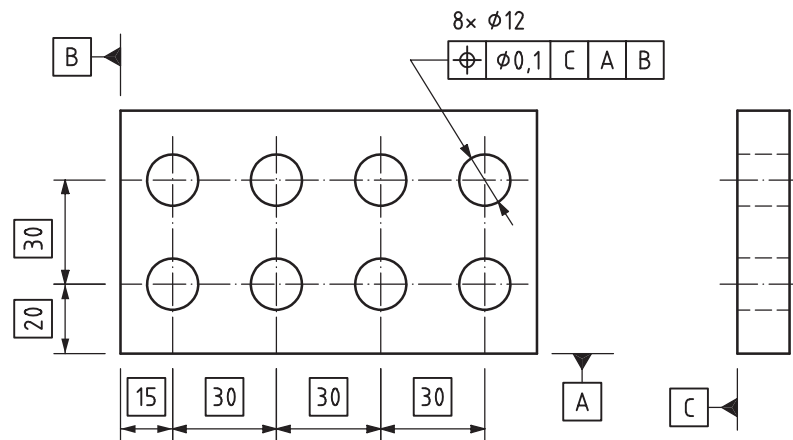
**Figure 153 — Definition of the position tolerance zones**

In [Figure 154](#), the extracted median line shall be within a cylindrical zone of diameter 0,08, the axis of which coincides with the theoretically exact position of the considered hole, with respect to datum planes C, A and B.

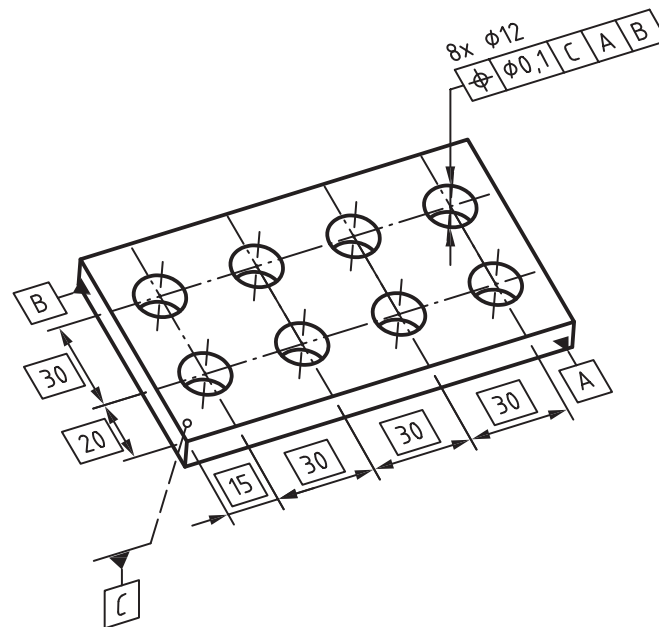


**Figure 154 — Position indication**

In [Figure 155](#), the extracted median line of each hole shall be within a cylindrical zone of diameter 0,1, the axis of which coincides with the theoretically exact position of the considered hole, with respect to datum planes C, A, and B.



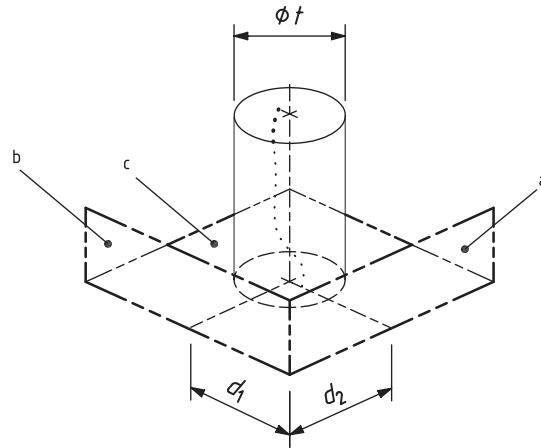
a) 2D



b) 3D

**Figure 155 — Position indication**

The tolerance zones defined by the specifications in [Figure 154](#) and [Figure 155](#) are limited by a cylinder of diameter  $t$ , because the tolerance value is preceded by the symbol  $\phi$ . The axis of the cylindrical tolerance zone is fixed by theoretically exact dimensions with respect to datums C, A and B, see [Figure 156](#).

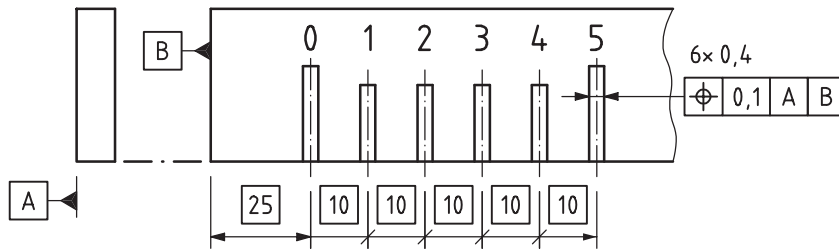


- a Datum A.
- b Datum B.
- c Datum C.

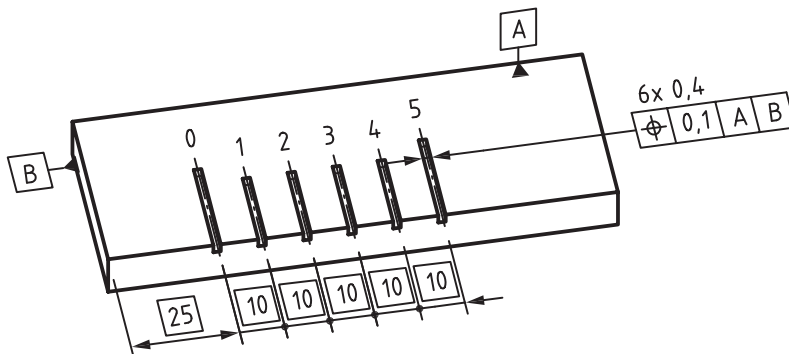
Figure 156 — Definition of the position tolerance zone

17.13.4 Position specification of a median plane

In Figure 157, the extracted median plane of each of the scribe lines shall be contained between two parallel planes 0,1 apart, which are symmetrically disposed about the theoretically exact position of the considered line, with respect to datum planes A and B.



a) 2D



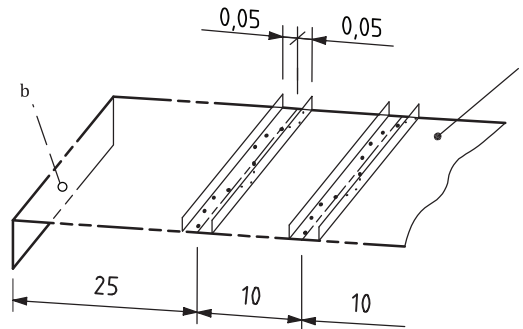
b) 3D

Figure 157 — Position indication

The tolerance zone for each of the six tolerated features defined by the specification in Figure 157 is limited by two parallel planes 0,1 apart and symmetrically disposed about the centre line for that



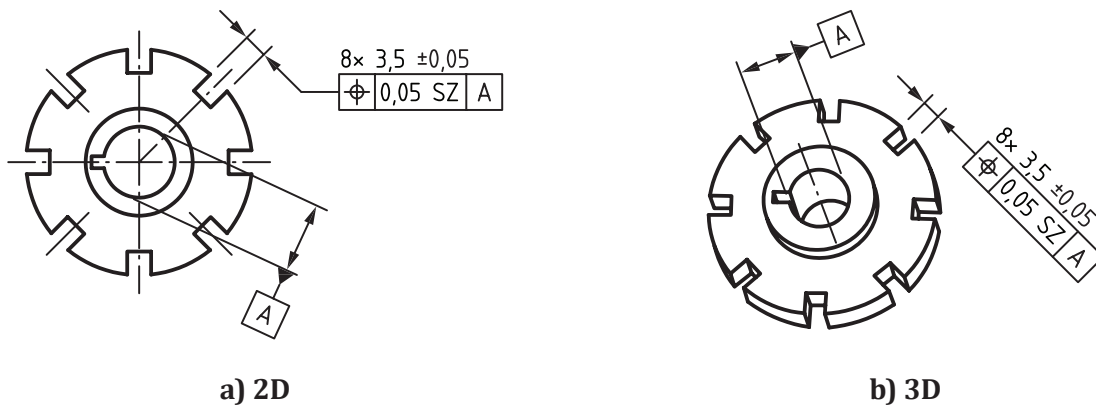
feature. The median plane is fixed by theoretically exact dimensions with respect to datums A and B. The specification applies in one direction only, see [Figure 158](#).



- a Datum A.
- b Datum B.

**Figure 158 — Definition of the position tolerance zone**

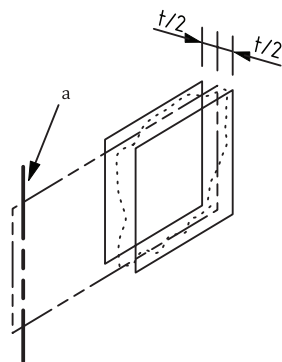
In [Figure 159](#), for each of the eight toleranced features considered independently (disregarding the angles between them), the extracted median surface shall be contained between two parallel planes 0,05 apart, which are symmetrically disposed about the theoretically exact position of the median plane, with respect to datum axis A.



**Figure 159 — Position indication**

The tolerance zone defined by the specification in [Figure 159](#) is limited by two parallel planes a distance 0,05 apart and symmetrically disposed around datum A, see [Figure 160](#).

NOTE With the SZ specification element, the angles between the tolerance zones for the eight slots are not locked. If the CZ specification element had been used instead, the tolerance zones would have been locked at 45° intervals.



a Datum A.

Figure 160 — Definition of the position tolerance zone

### 17.13.5 Position specification of a planar surface

In [Figure 161](#), the extracted surface shall be contained between two parallel planes 0,05 apart, which are symmetrically disposed about the theoretically exact position of the surface, with respect to datum plane A and datum axis B.

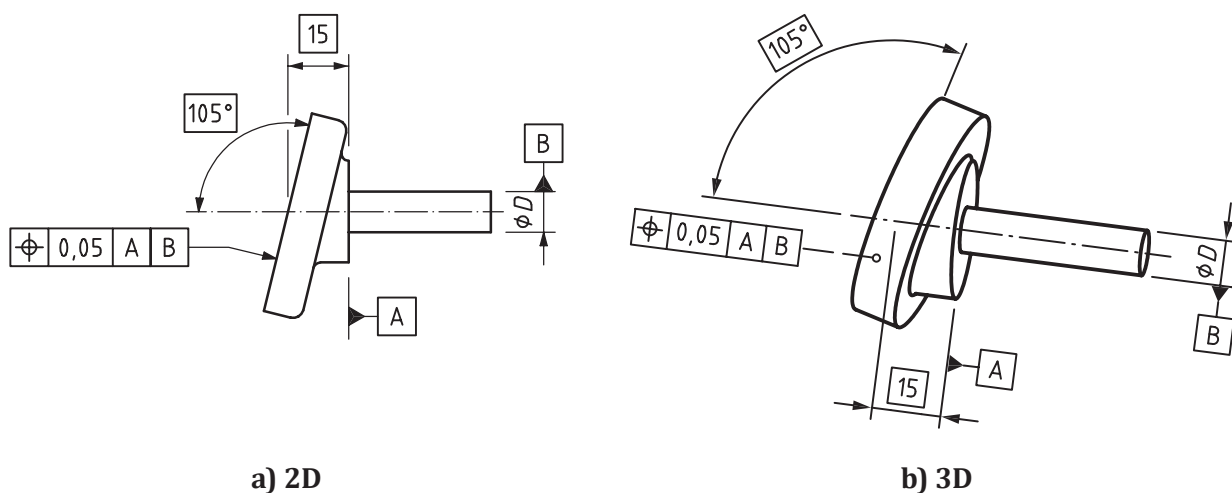
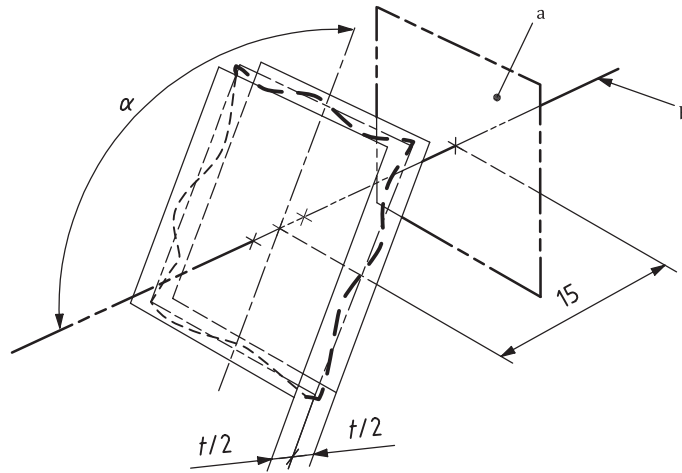


Figure 161 — Position indication

The tolerance zone defined by the specification in [Figure 161](#) is limited by two parallel planes a distance  $t$  apart and symmetrically disposed about the theoretically exact position fixed by theoretically exact dimensions with respect to datums A and B, see [Figure 162](#).



- a Datum A.
- b Datum B.

Figure 162 — Definition of the position tolerance zone

## 17.14 Concentricity and coaxiality specification

### 17.14.1 General

The tolerated feature is a derived feature. The nature and shape of the nominal tolerated feature is a point, a set of points, or a straight line. If the indicated feature is a nominally straight line, the specification element ACS shall be indicated if the tolerated feature is a set of points. In this case, the datum for each point is also a point in the same cross-section. The angular and linear dimensions that are locked between the nominal tolerated feature and the datums shall be defined by implicit TEDs.

### 17.14.2 Concentricity specification of a point

In [Figure 163](#), the extracted centre of the inner circle in any cross-section shall be within a circle of diameter 0,1, concentric with datum point A defined in the same cross-section.

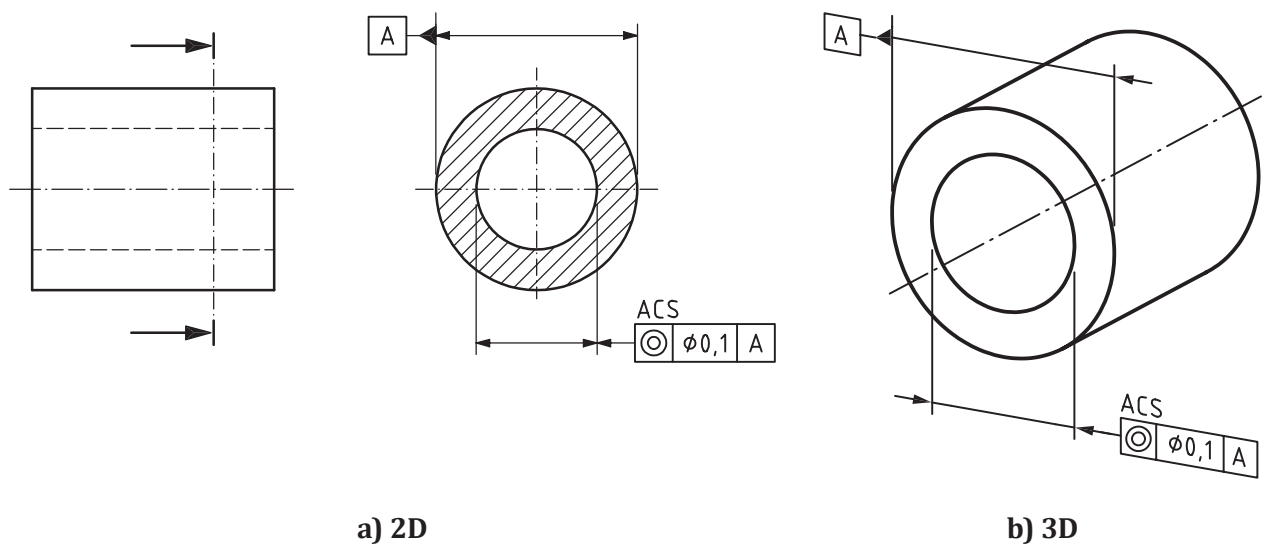
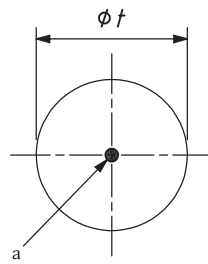


Figure 163 — Concentricity indication

The tolerance zone defined by the specification in [Figure 163](#) is limited by a circle of diameter  $t$ ; the tolerance value shall be preceded by the symbol  $\varnothing$ . The centre of the circular tolerance zone coincides with the datum point, see [Figure 164](#).

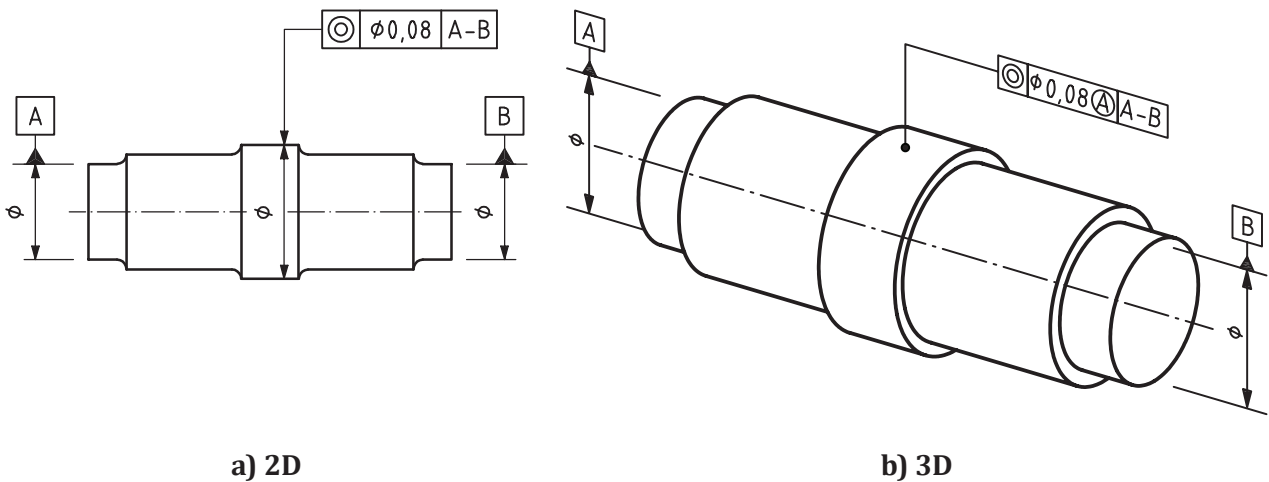


a Datum point A.

**Figure 164 — Definition of the concentricity tolerance zone**

### 17.14.3 Coaxiality specification of an axis

In [Figure 165](#), the extracted median line of the tolerated cylinder shall be within a cylindrical zone of diameter 0,08, the axis of which is the common datum straight line A-B.



**Figure 165 — Coaxiality indication**

In [Figure 166](#), the extracted median line of the tolerated cylinder shall be within a cylindrical zone of diameter 0,1, the axis of which is datum axis A.

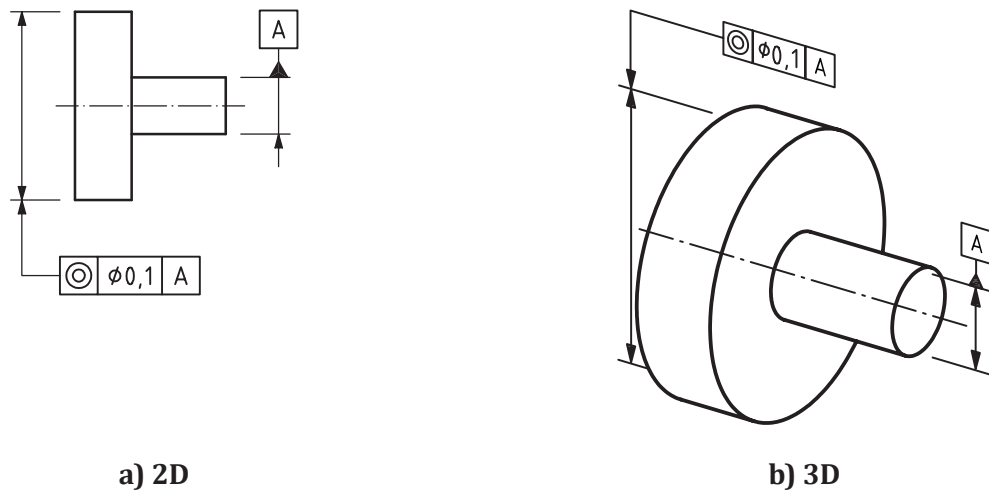


Figure 166 — Coaxiality indication

In [Figure 167](#), the extracted median line of the tolerated cylinder shall be within a cylindrical zone of diameter 0,1, the axis of which is datum axis B, which is perpendicular to datum plane A.

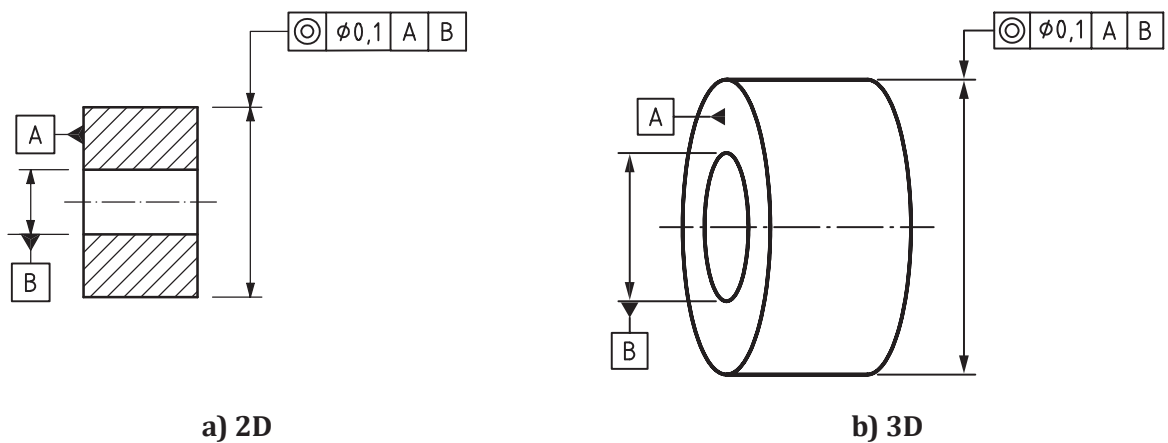
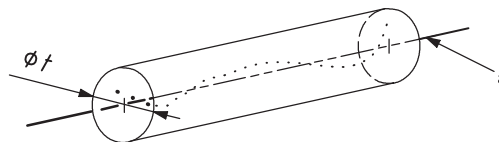


Figure 167 — Coaxiality indication

The tolerance zones defined by the specifications in [Figure 165](#), [Figure 166](#) and [Figure 167](#) are limited by a cylinder with a diameter equal to the tolerance value, because it is preceded by the symbol  $\varnothing$ . The axis of the cylindrical tolerance zone coincides with the datum, see [Figure 168](#).



- a Datum A-B ([Figure 165](#)) or datum A ([Figure 166](#)) or secondary datum B perpendicular to primary datum A (not shown) ([Figure 167](#)).

Figure 168 — Definition of the coaxiality tolerance zone

### 17.15 Symmetry specification

#### 17.15.1 General

The tolerated feature is either an integral feature or a derived feature. The nature and shape of the nominal tolerated feature is a point, a set of points, a straight line, a set of straight lines, or a flat surface. If the indicated feature is a nominally flat surface, an intersection plane indicator shall be indicated, if the tolerated feature is a set of straight lines in the surface. If the indicated feature is a nominally straight line, the specification element ACS shall be indicated, if the tolerated feature is a set of points on the line. In this case, the datum for each point is also a point in the same cross-section. At least one datum that locks a non-redundant translation of the tolerance zone shall be indicated in the tolerance indicator. The angular and linear dimensions that are locked between the nominal tolerated feature and the datums are defined by implicit TEDs.

A symmetry specification can be used in all cases where a position specification can be used, provided all the relevant linear TEDs are zero.

#### 17.15.2 Symmetry specification of a median plane

In [Figure 169](#), the extracted median surface shall be contained between two parallel planes 0,08 apart, which are symmetrically disposed about datum plane A.

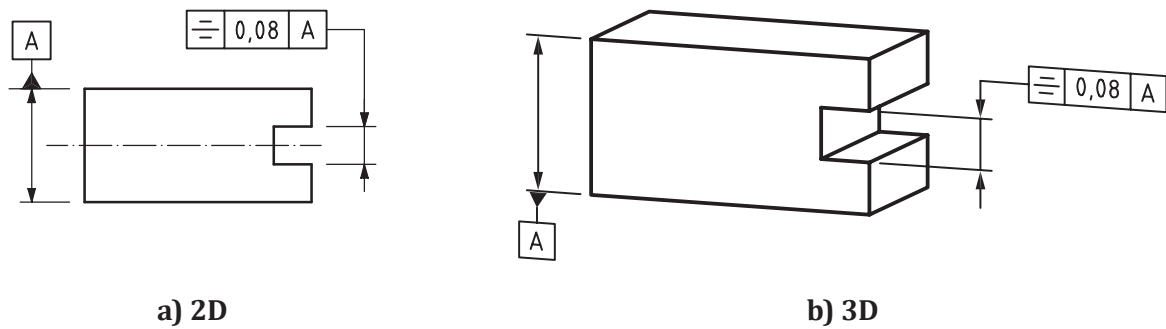


Figure 169 — Symmetry indication

In [Figure 170](#), the extracted median surface shall be contained between two parallel planes 0,08 apart, which are symmetrically disposed about the common datum plane A-B.

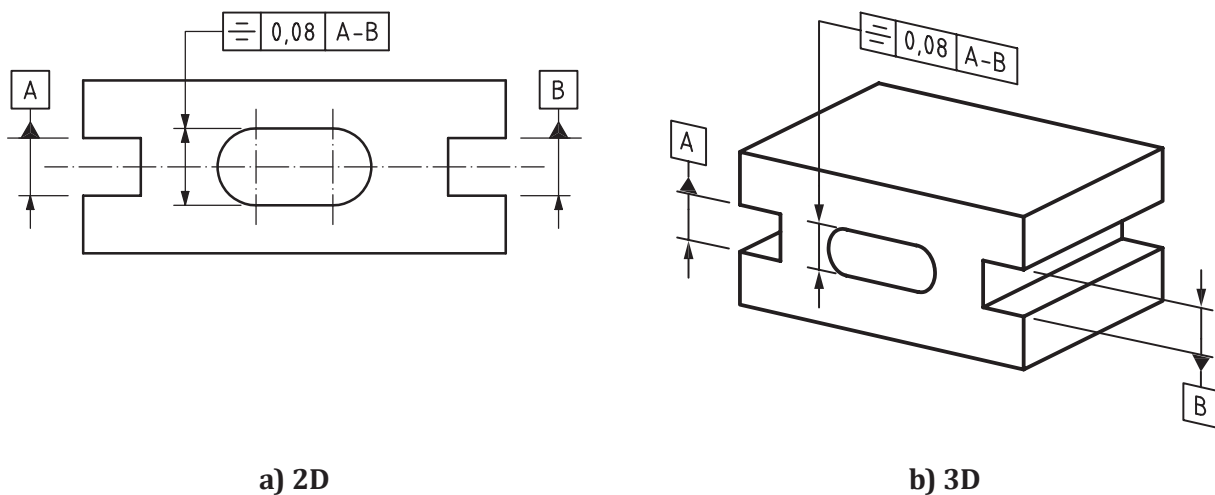
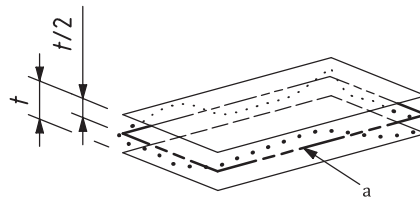


Figure 170 — Symmetry indication

The tolerance zones defined by the specifications in [Figure 169](#) and [Figure 170](#) are limited by two parallel planes a distance 0,08 apart, symmetrically disposed about the median plane, with respect to the datum, see [Figure 171](#).



a Datum.

**Figure 171 — Definition of the symmetry tolerance zone**

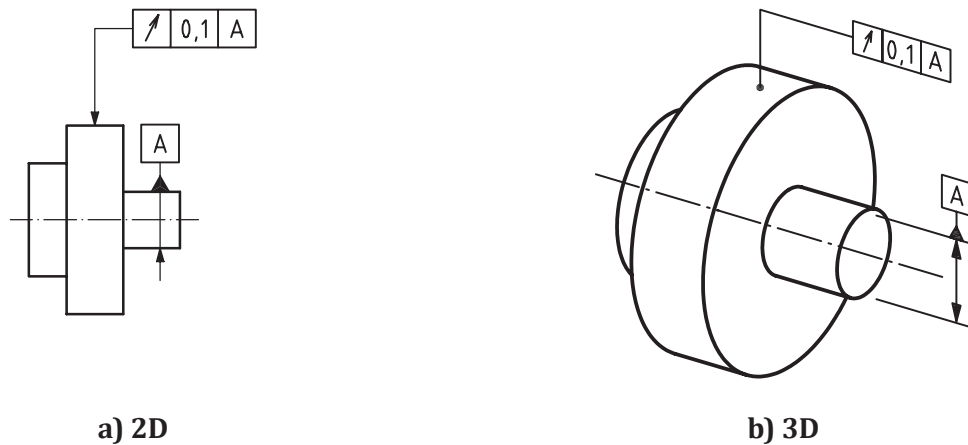
## 17.16 Circular run-out specification

### 17.16.1 General

The tolerated feature is an integral feature. The nature and shape of the nominal tolerated feature is explicitly given as a circular line or a set of circular lines, which is a linear feature.

### 17.16.2 Circular run-out specification — Radial

In [Figure 172](#), the extracted line in any cross-section plane perpendicular to datum axis A shall be contained between two coplanar concentric circles with a difference in radii of 0,1.



**Figure 172 — Circular run-out indication**

In [Figure 173](#), the extracted line in any cross-section plane parallel to datum plane B shall be contained between two coplanar circles that are concentric to datum axis A, with a difference in radii of 0,1.

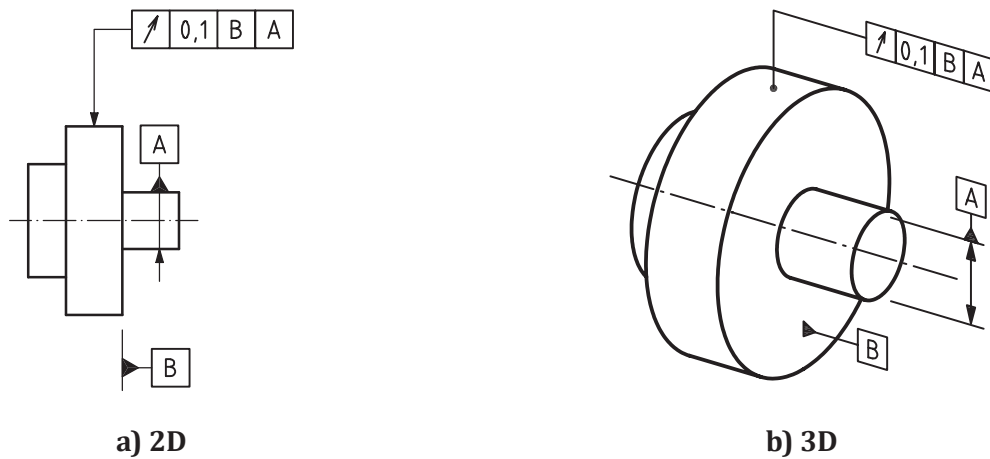


Figure 173 — Circular run-out indication

In [Figure 174](#), the extracted line in any cross-section plane perpendicular to common datum straight line A-B shall be contained between two coplanar concentric circles with a difference in radii of 0,1.

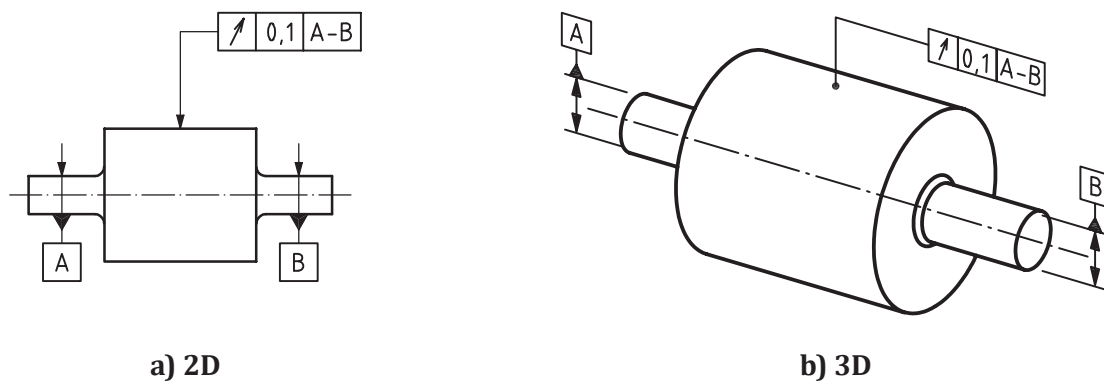
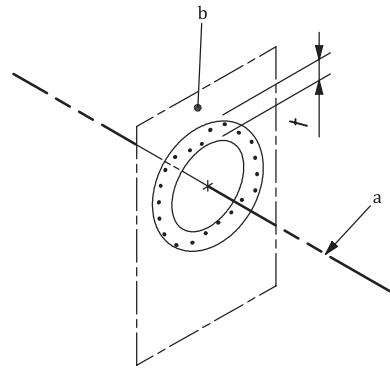


Figure 174 — Circular run-out indication

The tolerance zones defined by the specifications in [Figure 172](#), [Figure 173](#) and [Figure 174](#) are limited within any cross-section perpendicular to the datum axis by two concentric circles with a difference in radii of 0,1, the centres of which coincide with the datum, see [Figure 175](#).

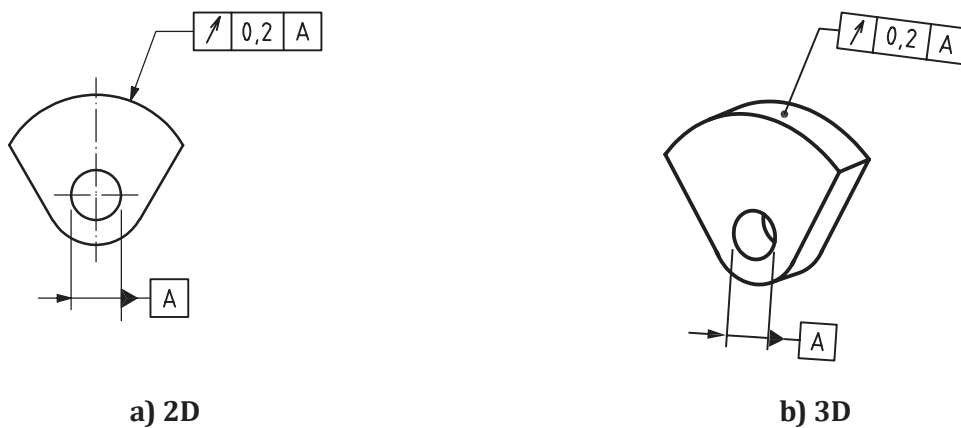




- a Datum A (Figure 172).  
Secondary datum A perpendicular to datum B (Figure 173).  
Datum A-B (Figure 174).
- b Cross-section plane perpendicular to datum A (Figure 172).  
Cross-section plane parallel to datum B (Figure 173).  
Cross-section plane perpendicular to datum A-B (Figure 174).

**Figure 175 — Definition of the circular run-out tolerance zone**

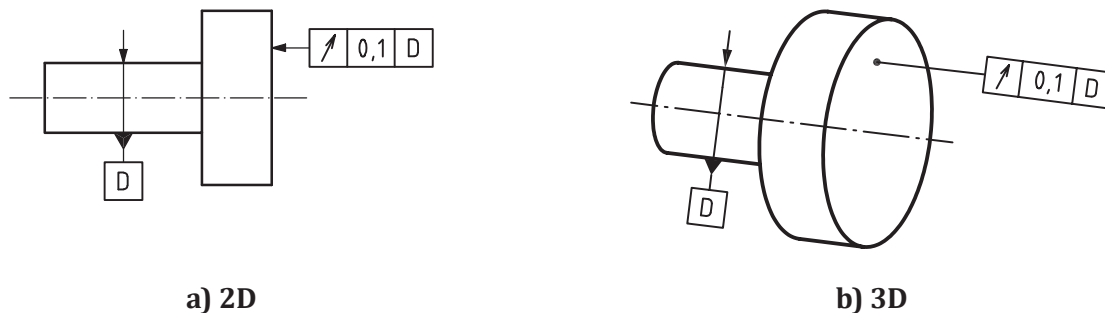
In Figure 176, the extracted line in any cross-section plane perpendicular to datum axis A shall be contained between two coplanar concentric circles with a difference in radii of 0,2.



**Figure 176 — Circular run-out indication**

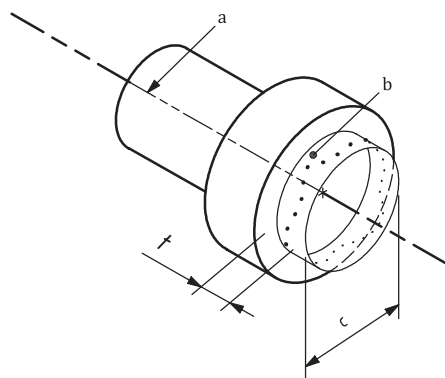
### 17.16.3 Circular run-out specification — Axial

In Figure 177, the extracted line in any cylindrical section, the axis of which coincides with datum axis D, shall be contained between two circles with an axial distance of 0,1.



**Figure 177 — Circular run-out indication**

The tolerance zone defined by the specification in [Figure 177](#) is limited in any cylindrical section by two circles an axial distance of 0,1 apart lying in the cylindrical section, the axis of which coincides with the datum, see [Figure 178](#).



- a Datum D.
- b Tolerance zone.
- c Any diameter coaxial with datum D.

**Figure 178 — Definition of the circular runout tolerance zone**

#### 17.16.4 Circular runout in any direction

In [Figure 179](#), the extracted line in any conical section, with an apex angle such that the section is perpendicular to the tolerated feature, the axis of which coincides with datum axis C, shall be contained between two circles within the conical section with a distance of 0,1.

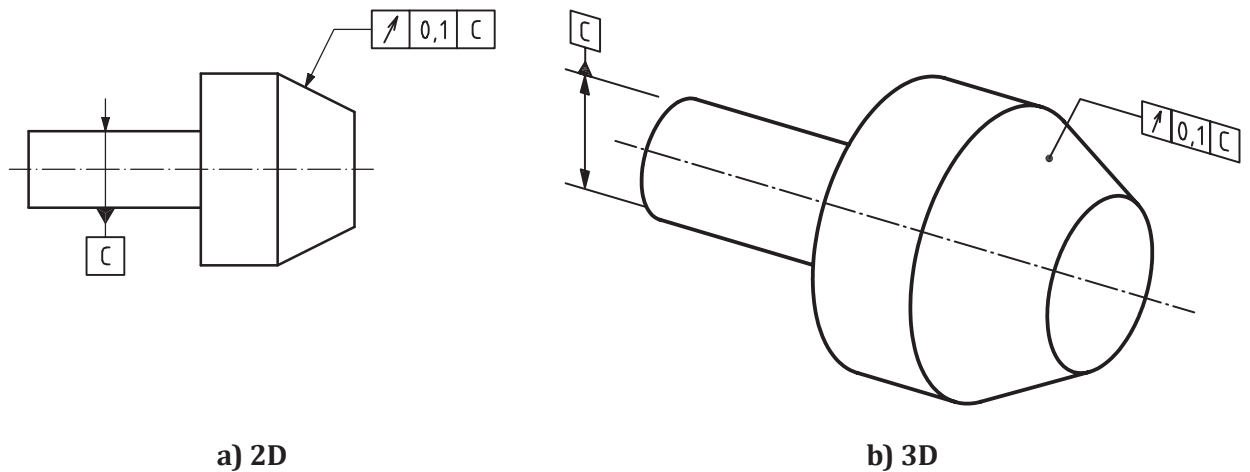


Figure 179 — Circular run-out indication

When the generator line for the tolerated feature is not straight, as in [Figure 180](#), the apex angle of the conical section will change depending on the actual position to remain perpendicular to the tolerated feature.

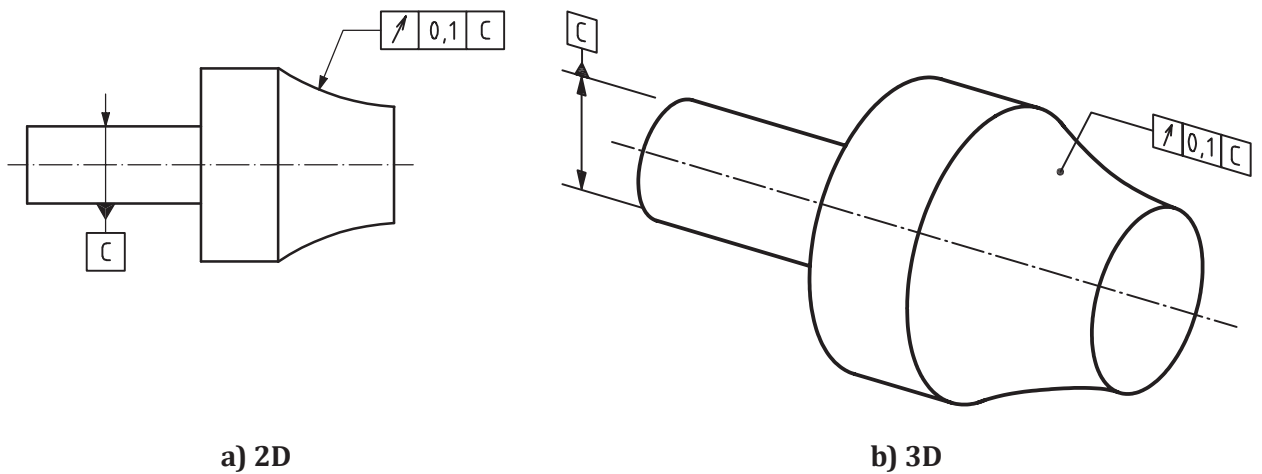
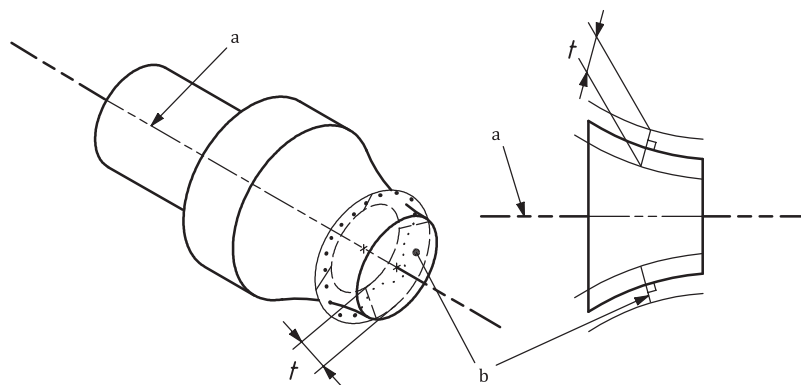


Figure 180 — Circular run-out indication

The tolerance zone defined by the specification in [Figure 180](#) is limited within any conical section by two circles a distance of 0,1 apart, the axes of which coincide with the datum, see [Figure 181](#).

The width of the tolerance zone is normal to the specified geometry unless otherwise indicated.

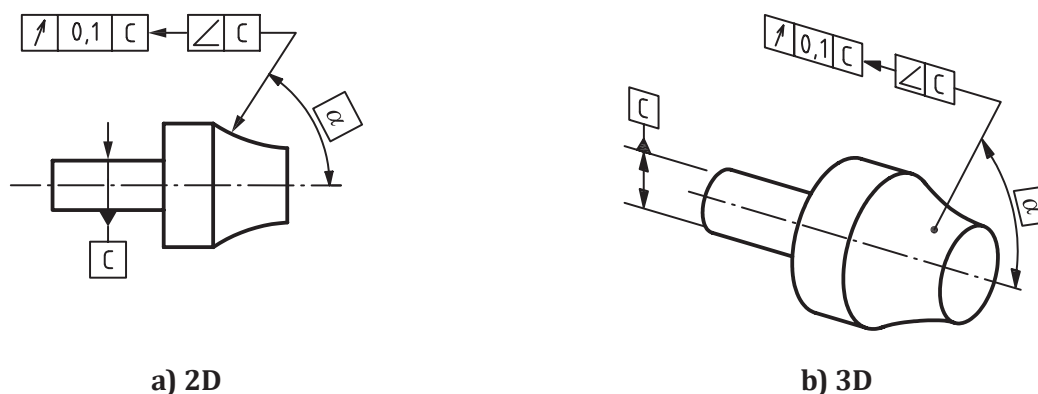


- a Datum C.
- b Tolerance zone.

**Figure 181 — Definition of the circular run-out tolerance zone**

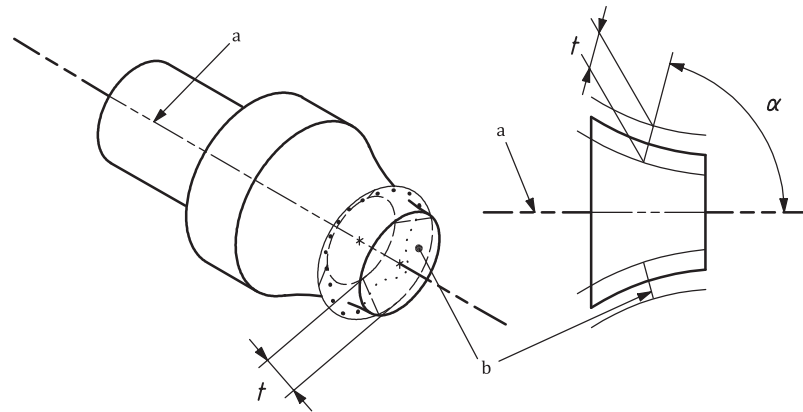
**17.16.5 Circular run-out specification in a specified direction**

In [Figure 182](#), the extracted line in any conical section corresponding to a direction feature (angle  $\alpha$ ) shall be contained between two circles 0,1 apart within the conical section.



**Figure 182 — Circular run-out indication**

The tolerance zone defined by the specification in [Figure 182](#) is limited within any conical section of the specified angle by two circles a distance  $t$  apart, the axes of which coincide with the datum, see [Figure 183](#).



- a Datum C.
- b Tolerance zone.

Figure 183 — Definition of the circular run-out tolerance zone

## 17.17 Total run-out specification

### 17.17.1 General

The tolerated feature is an integral feature. The nature and shape of the nominal tolerated feature is a flat surface or a cylindrical surface. The tolerance zone maintains the nominal shape of the tolerated feature, but for a cylindrical surface, the radial dimension is not constrained.

### 17.17.2 Total run-out specification — Radial

The extracted surface shall be contained between two coaxial cylinders with a difference in radii of 0,1 and the axes coincident with the common datum straight line A-B.

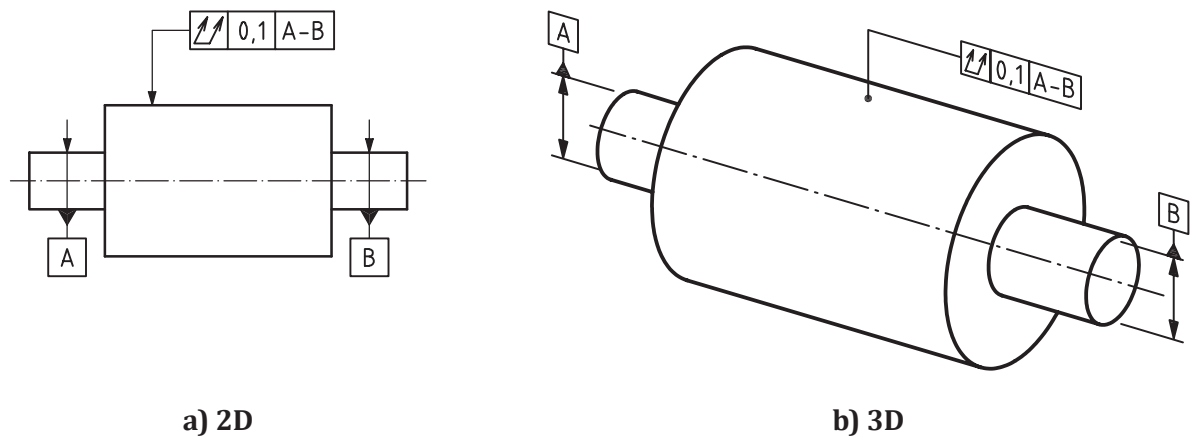
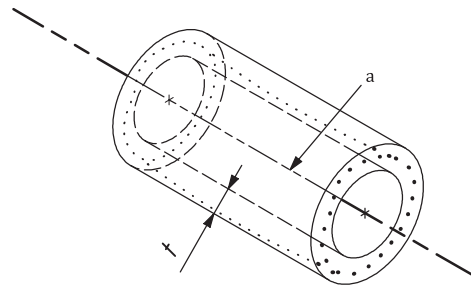


Figure 184 — Total run-out indication

The tolerance zone defined by the specification in [Figure 184](#) is limited by two coaxial cylinders with a difference in radii of  $t$ , the axes of which coincide with the datum, see [Figure 185](#).



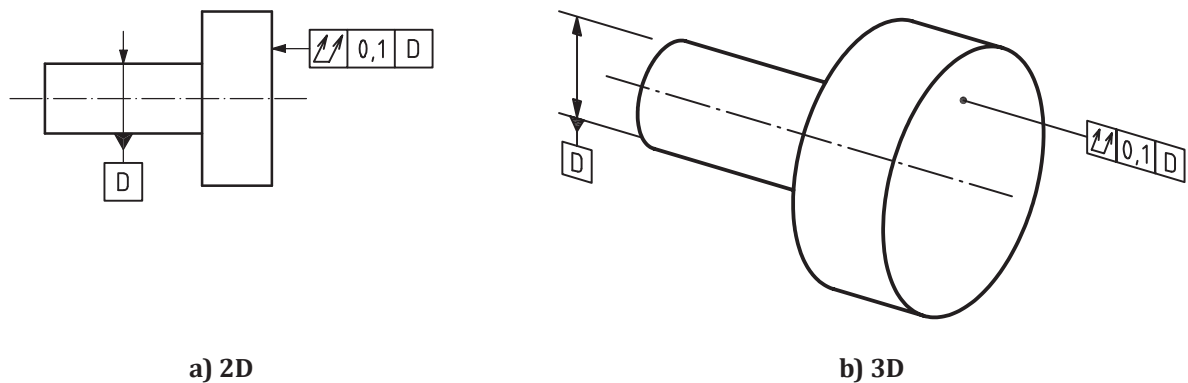
a Common datum A-B.

**Figure 185 — Definition of the total run-out tolerance zone**

**17.17.3 Total run-out specification – Axial**

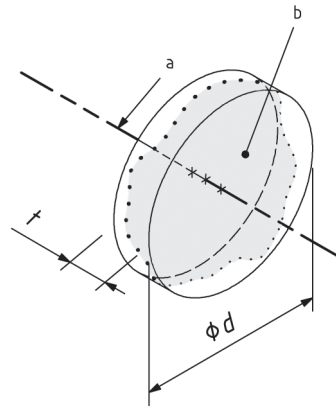
In [Figure 186](#), the extracted surface shall be contained between two parallel planes 0,1 apart, which are perpendicular to datum axis D.

NOTE A perpendicularity specification would have the same meaning.



**Figure 186 — Total run-out indication**

The tolerance zone defined by the specification in [Figure 186](#) is limited by two parallel planes a distance 0,1 apart and perpendicular to the datum, see [Figure 187](#).



- a Datum D.
- b Extracted surface.

**Figure 187 — Definition of the total run-out tolerance zone**

## Annex A (informative)

### Deprecated and former practices

#### A.1 General

This annex describes former practices that have been omitted and are no longer used. Therefore, they are not an integral part of this document, but should be used for information only.

#### A.2 Deprecated practice from ISO 1101:2012

The following drawing indications were described in ISO 1101:2012. They can still be used, but are expected to be phased out.

**A.2.1** The practice of relying on the drawing plane to define the intersection plane, e.g. for a straightness tolerance has been deprecated, in order to have similar indications in 2D and 3D. For the preferred indications, see [Figure 90](#), [Figure 104](#), [Figure 106](#) and [Figure 122](#).

**A.2.2** The LE specification element is used to indicate that the specification applied to line elements individually, see [Figure A.1](#). This specification element has been deprecated because the use of an intersection plane indicator makes LE superfluous. For the preferred indication, see [Figure 122](#).

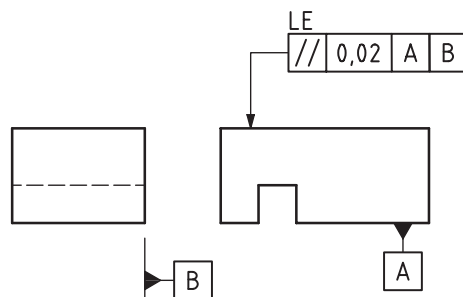


Figure A.1

**A.2.3** In an “all around” specification in 2D, the collection plane indicator can be omitted, see [Figure A.2](#), instead relying on the drawing plane to identify the collection plane. This practice has been deprecated to align the practices between 2D and 3D. For the preferred indication, see [Figure 53](#).

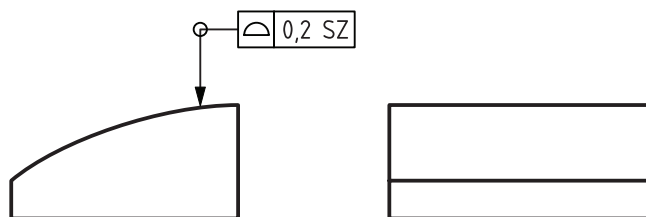
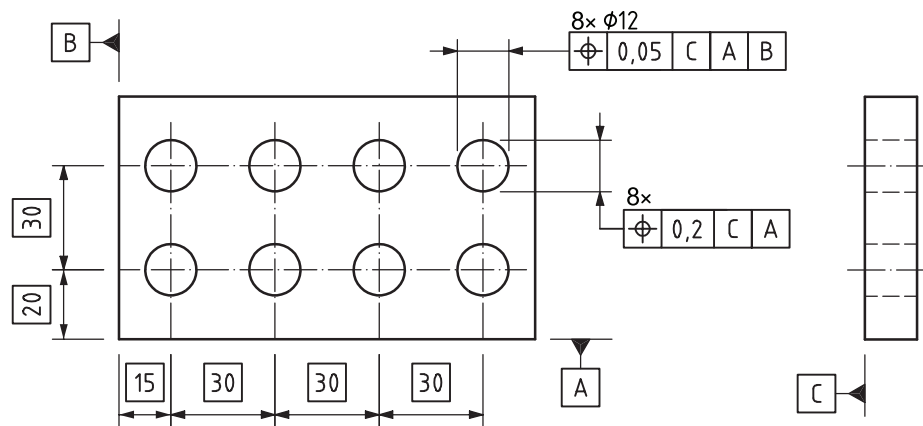


Figure A.2



**A.2.4** In a 2D specification, orientation plane indicators can be omitted, instead relying on the direction of the dimension line to define the orientation of the tolerance zone, see [Figure A.3](#). This practice has been deprecated to align the practices between 2D and 3D. For the preferred indication with the equivalent meaning, see [Figure 152 a\)](#)



**Figure A.3**

### A.3 Former practice from ISO 1101:2012

The following drawing indications were described in ISO 1101:2012. Their use in practice has shown that their interpretation was ambiguous. Therefore, these drawing indications should no longer be used.

**A.3.1** It was a former practice to use the NC specification element to indicate that the toleranced feature should be “non-convex”, see [Figure A.4](#). This specification element is no longer used, because it is ambiguous what exactly constitutes a non-convex feature, i.e. how close to the edge of the feature should a plane contact the feature for it to be considered non-convex. There is no replacement for this indication in this document, since it is a qualitative concept. If needed, it can be added as a note on the drawing.

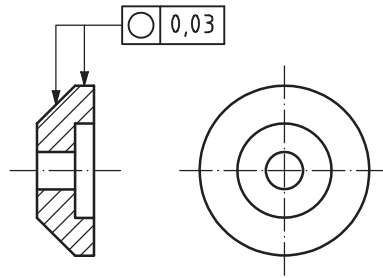


**Figure A.4**

**A.3.2** It was a former practice to use the “from...to” symbol “→” if the tolerance value was variable along the toleranced feature. Because the specification was unambiguous without the separate “from...to” symbol, practice has been changed to use the “between” symbol “↔” together with the letters identifying the start and the end of the toleranced feature in all cases where a specification either applies to a restricted part of a feature or the tolerance value was variable. For the current indication, see [Figure 14](#).

**A.3.3** It was former practice that for all revolutes, the default direction for roundness specifications was perpendicular to the associated axis of the revolute surface, see [Figure A.5](#). This was an exception to the general rule that geometrical specifications for integral features apply perpendicular to the surface. A

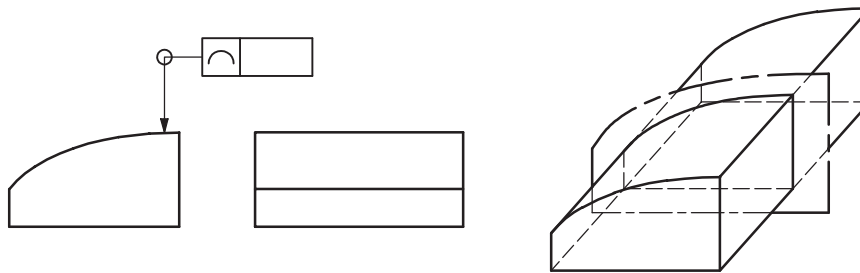
direction feature indicator shall now always be used to indicate the direction of roundness specifications for revolute surfaces that are neither cylindrical nor spherical, e.g. cones, see [Clause 15](#).



NOTE The current indications with the identical meaning is shown in [Figure 98](#).

**Figure A.5**

**A.3.4** In former versions of this document, it was not clear whether a specification to a set of features, e.g. an “all around” specification such as the one shown in [Figure A.6](#), created a set of tolerance zones that applied to each identified feature individually, as this document states explicitly in [9.1.2](#), see [Figure 53](#), or one common zone that applied to all the tolerated features, see [Figure 51](#). Therefore, it was a former practice in some countries and companies to interpret a specification for a set of features using an “all around” indication as defining one common zone that applied to all the tolerated features, locking them in orientation and location to each other.



**Figure A.6**

**A.3.5** It was a former practice to interpret a profile specification to apply “from edge to edge” and interpret the specification as if united feature, UF, had been indicated, even though that violated the feature principle, see ISO 8015, and even though it was not clearly defined what constituted an edge, see [Figure A.7](#). For the current indication for this meaning, see [Figure 104](#).

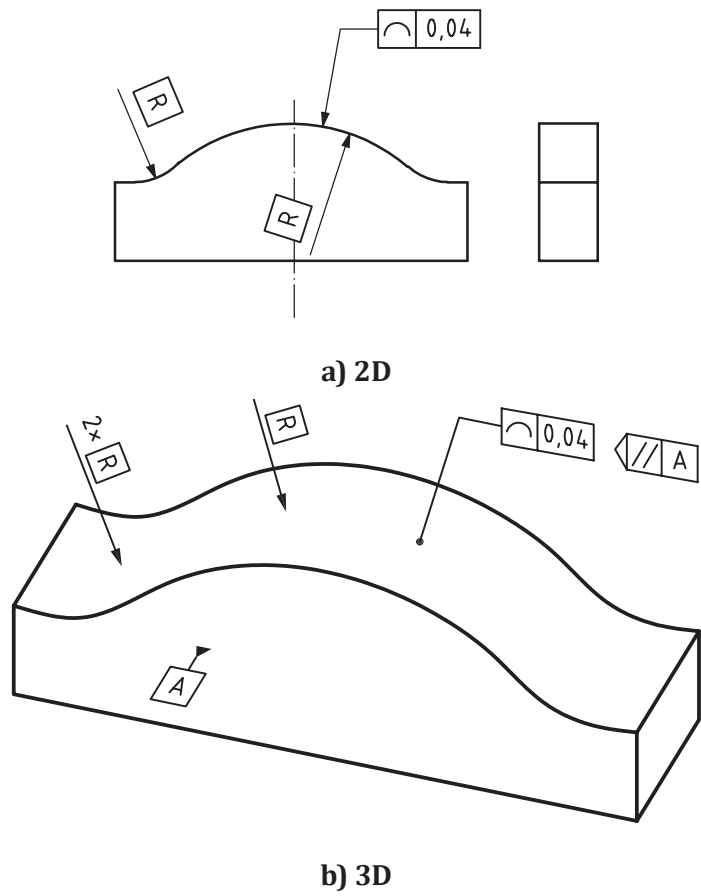


Figure A.7

**A.3.6** It was former practice in the case of a specification for a centre point or a median line in one direction that the arrow of the leader line defined the orientation of the tolerance zone, in some cases combined with a secondary datum, see [Figures A.8](#) to [A.11](#).

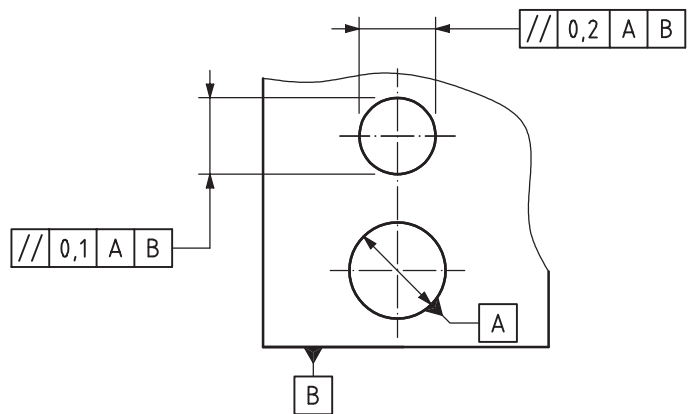


Figure A.8

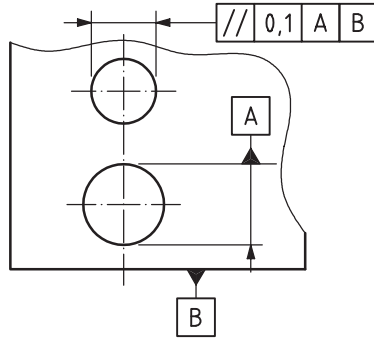


Figure A.9

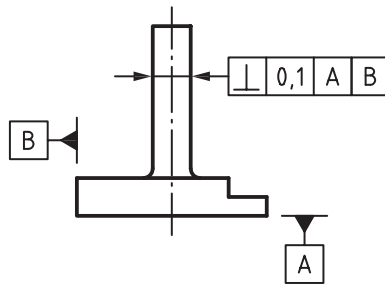


Figure A.10

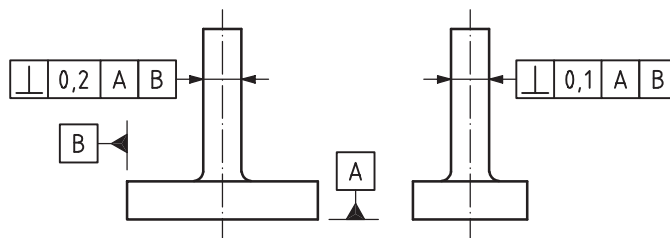


Figure A.11

This is not precise when used in 2D and ambiguous when used in 3D. The current indication with the identical meaning is shown in [Figure 116](#), [Figure 114](#), [Figure 130](#) and [Figure 132](#), respectively.

**A.3.7** It was a former practice to rely on common practice amongst metrologists, e.g. in terms of measuring instrument characteristics, sampling density and filter settings to limit the variability of results seen in verification in the absence of explicit filtering specifications. Because different metrologists made different choices, this led to variation in results and therefore ambiguity in the specification. Where such variations were excessive or influenced the function of the workpiece, drawing notes or inspection instructions were typically used to limit the variation. This document introduces specification elements to indicate filtering, see [8.2.2.2.1](#) and [Annexes C](#) and [E](#)

**A.3.8** It was a former practice to indicate a datum on a cylindrical part as shown in [Figure A.12](#) and [Figure A.13](#). These indications are ambiguous and should be avoided. In some countries and companies, [Figure A.12](#) was interpreted as referring to the hole as the datum feature and [Figure A.13](#) was interpreted

as referring to the outside diameter of the shaft as the datum feature. In other countries and companies, the figures were interpreted as referring to the generatrix as the datum feature.

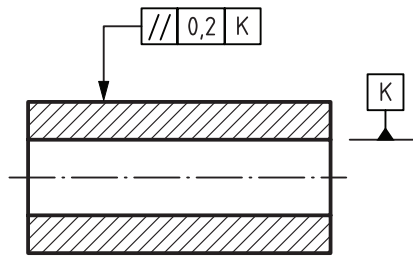


Figure A.12

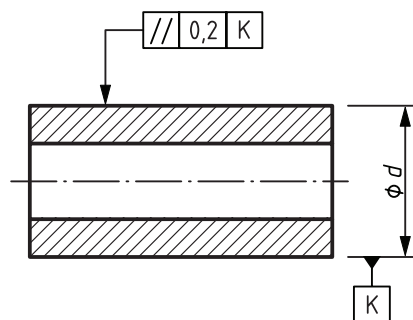


Figure A.13

Formally, the syntax of the indications is not correct. If it is the cylindrical feature that is intended as the datum feature, the datum indicator shall be aligned with a dimension line. If it is the generatrix that is intended, it shall be indicated as a datum target, because the feature principle means that an indication refers to the entire identified feature, unless otherwise specified. For the current rules for datum feature indication, see ISO 5459.

**A.3.9** It was a former practice to enclose the offset in square brackets for a specification using the UZ specification element. This practice has changed, as the specification is unambiguous without the square brackets. For the current indication, see [Figure 22](#).

**A.3.10** The line profile specification symbol was called “profile any line” in former versions of this document.

The surface profile specification symbol was called “profile any surface” in former versions of this document.

#### A.4 Former practice from ISO 1101:1983

The following drawing indications were described in ISO 1101:1983. Their use in practice has shown that their interpretation was ambiguous. Therefore, these drawing indications should no longer be used.

**A.4.1** It was a former practice to connect the tolerance indicator by a leader line terminating with an arrow directly to the axis or median plane (see [Figure A.14](#)) or common axis or median plane (see

Figures A.15 and A.16) when the specification referred to such feature(s). This was used as an alternate method to the indications shown in Figures 4, 5 and 6.

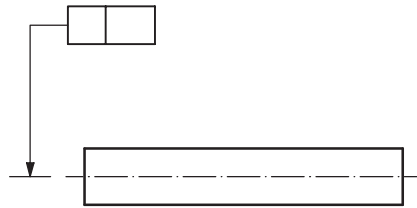


Figure A.14

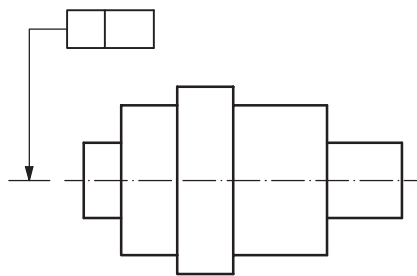


Figure A.15

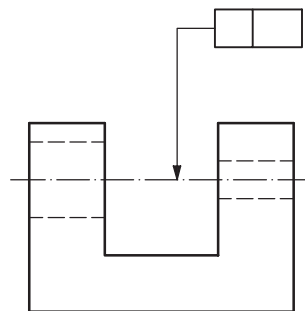


Figure A.16

**A.4.2** It was a former practice to connect the datum triangle and the datum letter directly to the axis or median plane or common axis or median plane (see Figure A.17) when the datum referred to such feature(s). For the current rules for datum feature indication, see ISO 5459.

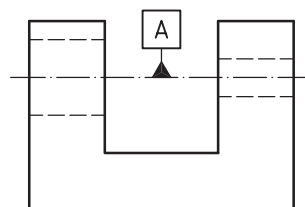
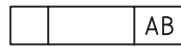


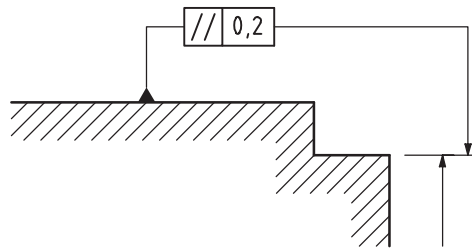
Figure A.17

**A.4.3** It was former practice to indicate datum letters without giving them an order of precedence (see [Figure A.18](#)). Therefore, it was not possible to clearly distinguish between the primary and secondary datum. For the current rules for datum feature indication, see ISO 5459.

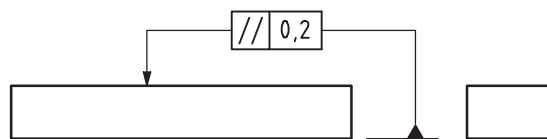


**Figure A.18**

**A.4.4** It was former practice to connect the tolerance indicator directly to the datum feature by a leader line (see [Figures A.19](#) and [A.20](#)). The current indication with similar meaning is shown in [Figure 126](#). For the current rules for datum feature indication, see ISO 5459.

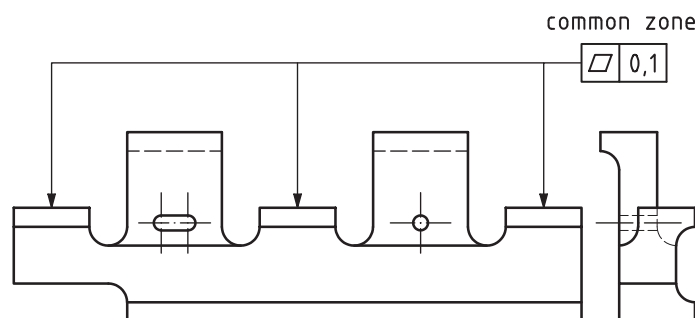


**Figure A.19**




**Figure A.20**

**A.4.5** It was former practice to indicate the requirement for common zone by placing the label “common zone” near the tolerance indicator (see [Figures A.21](#) and [A.22](#)). This was used as an alternate method to the method described in [8.2.2.1.2](#).



**Figure A.21**

3 × A  
common zone  

	0,1
---	-----

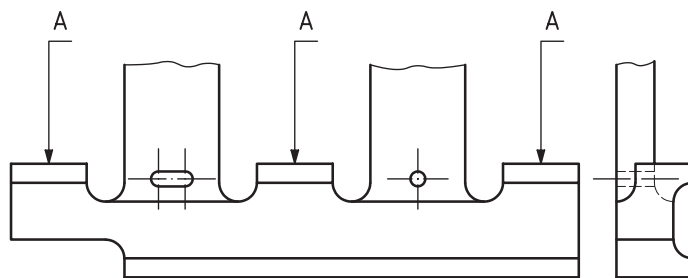


Figure A.22



## Annex B (informative)

### Explicit and implicit rules for geometrical tolerance zones

#### B.1 Tolerance indicator

The tolerance indicator for a geometrical specification defines the toleranced feature, the specified characteristic and tolerances zone(s) and the relations between tolerance zones for the toleranced feature(s) and a datum or a datum system.

#### B.2 Tolerance zone

Geometrical tolerance zones are established from the nominal model (theoretically exact geometry) Tolerance zones are limited by theoretical exact geometries defined from theoretically exact features (TEFs).

#### B.3 Theoretical exact dimension (TED)

TED(s) exist in the nominal model.

A TED can be a linear TED (length unit) or an angular TED (angle unit).

TED(s) can only be used for the following purposes:

- connection of two or more tolerance zones;
- connection of one or more tolerance zones to a datum or datum system;
- definition of a theoretical exact feature (TEF);
- connection and orientation of datum targets;
- location and dimensions of a restricted toleranced feature;
- direction of the width of the tolerance zone.

An implicit linear TED zero (0) is created, if a point or a line is indicated on a datum axis or a datum plane on the drawing.

Implicit angular TEDs of zero (0°) and/or 90° can be created, if a pattern is indicated on the drawing, see ISO 5458.

Implicit angular TEDs of zero (0°) and 90° are also created for the relation between a tolerance zone (type two parallel planes and type cylinder) and the planes and axes of a datum or datum system, if no other TED angles are indicated on the drawing and the specification references these datums.

Implicit angular TEDs (360°/Number of tolerance zones) are created between tolerance zones indicated on the drawing as equally distributed on a circle.

#### B.4 Pattern

A pattern contains two or more tolerance zones connected by TED(s), see ISO 5458.

Members of a pattern shall be positively identified (e.g. 4×, etc.).

## B.5 Theoretical exact feature (TEF)

The shape of the theoretical exact feature (TEF) for a toleranced feature is defined implicitly by the drawing view(s) or by the CAD model. The dimensions of the TEF are defined by implicit and/or explicit TEDs or by other means, e.g. formulae, tables and interpolation algorithms, CAD data, etc.

## B.6 Relations between theoretical exact features

Relations between two or more theoretical exact features are established by implicit or explicit TED(s), or both.

## B.7 Relation between theoretical exact feature(s) and a datum or a datum system

Relations between theoretical exact feature(s) and a datum or a datum system are established by one or more implicit and/or indicated TEDs.

## B.8 Shape of tolerance zones

When the toleranced feature is a surface (integral or derived), the shape of the surfaces limiting the tolerance zone are defined from the theoretical exact feature, TEF, (integral or derived).

When the toleranced feature is an integral straight line the shape of the tolerance zone is the space between two parallel lines, see e.g. [Figures 90](#) and [91](#) or two non-parallel lines. The latter is the case when the tolerance zone has a variable width, see [7.2](#).

When the toleranced feature is an integral circle the shape of the tolerance zone is the space between two concentric circles, see e.g. [Figures 98](#) and [99](#), two parallel circles on a conical surface, or two parallel circles of the same diameter.

When the toleranced feature is a median line the shape of the tolerance zone is:

- the space between two parallel planes or two non-parallel planes (i.e. a wedge, when the tolerance zone has a variable width, see [7.2](#)) when the shape is not given by the indication  $\emptyset$  in front of the tolerance value and the toleranced feature is nominally straight, see e.g. [Figures 112](#) and [113](#);
- a cylinder or a cone (when the tolerance zone has a variable width, see [7.2](#)) when the shape is given by the indication  $\emptyset$  in front of the tolerance value and the toleranced feature is nominally straight, see e.g. [Figures 118](#) and [119](#);
- a non-straight circular or conical tube (when the tolerance zone has a variable width, see [7.2](#)) when the shape is given by the indication  $\emptyset$  in front of the tolerance value and the tolerance feature is nominally non-straight, see ISO 1660.

When the toleranced feature is a derived centre of a sphere, the shape of the tolerance zone is:

- the space between two parallel planes when the shape is not given by the indication  $\emptyset$  or  $S\emptyset$  in front of the tolerance value,
- a cylinder when the shape is given by the indication  $\emptyset$  in front of the tolerance value, or
- a sphere when the shape is given by the indication  $S\emptyset$  in front of the tolerance value, see e.g. [Figures 150](#) and [151](#).

When the toleranced feature is a derived centre of a circular cross-section and the shape is given by the indication  $\emptyset$  in front of the tolerance value, the shape of the tolerance zone is a circle, see e.g. [Figures 163](#) and [164](#).

NOTE A derived centre point exists for a sphere, a circle and a torus. The derived centre point of a torus cannot be specified with the current rules.

## B.9 Position of the limiting surfaces of a tolerance zone relative to the theoretical exact feature (TEF)

When the toleranced feature is a surface (unrelated or related to a datum or a datum system) the limiting surfaces of the tolerance zone are established as the envelope surfaces of points at a distance  $0,5 \times t$  (on both sides) from points on the theoretical exact feature TEF (surface), which in this case is the reference feature, where  $t$  is the tolerance value. At the edge of the toleranced feature, the limiting surfaces are extended assuming tangent continuity of the toleranced feature.

The default orientation of the distance  $0,5 \times t$  is perpendicular to the theoretical exact surface in each point.

Other orientations can be controlled by orientation plane indicators, see [Clause 14](#), or direction feature indicators, see [Clause 15](#).

At discontinuity points the limiting surface is a sphere,  $SR = 0,5 \times t$  connecting the limiting surfaces, where  $t$  is the tolerance value.

NOTE The tolerance zone can be related to a TEF or a pattern or to a datum or datum system by TED(s).

## B.10 Geometrical characteristic symbol rules

### B.10.1 Toleranced feature

The toleranced feature is by default a complete single feature.

A nominal complex feature may consist of:

- a set of portions of planes, cylinders, spheres, cones, or tori (or a combination of these);
- a set of portions of straight lines or circles.

A restricted feature indication, a united feature indication or a combined zone indication may be used to specify such a feature as one continuous feature. Without such an indication, the toleranced feature is only:

- the single portion of this complex feature identified by the leader line;
- the set of features identified by the leader line(s), an “all around” modifier, or an “all over” modifier considered individually.

### B.10.2 Form specifications

When a *form* specification uses the geometrical characteristic symbol of

- Flatness, cylindricity:
  - The shape of the nominal toleranced feature is explicitly given.
  - The areal nature of the nominal toleranced feature is explicitly given.
- Straightness, roundness:
  - The shape of the nominal toleranced feature is explicitly given.
  - The linear nature of the nominal toleranced feature is explicitly given.
- Surface profile:
  - The shape of the nominal toleranced feature is explicitly given by complete indications on the drawing or by queries of the CAD model, see ISO 16792.

- The areal nature of the nominal toleranced feature is explicitly given.
- Line profile:
  - The shape of the nominal toleranced feature is explicitly given by complete indications on the drawing or by queries of the CAD model, see ISO 16792.
  - The linear nature of the nominal toleranced feature is explicitly given.

### B.10.3 Orientation specifications

When an *orientation* specification uses the geometrical characteristic symbol of:

- Parallelism, perpendicularity:
  - The shape of the nominal toleranced feature is a straight line or a plane.
  - When both are possible then the toleranced feature is by default the plane, unless an intersection plane indicator is indicated.
  - The TED angles between the nominal toleranced feature and the datum or datum system are implicitly defined as 0° for parallelism and 90° for perpendicularity.
- Angularity:
  - The shape of the nominal toleranced feature is a straight line or a plane.
  - When both are possible then the toleranced feature is by default the plane, unless an intersection plane indicator is indicated.
  - At least one explicit TED angle between the nominal toleranced feature and the datum or datum system shall be defined.
- Surface profile or line profile:
  - The shape of the nominal toleranced feature is explicitly given by the complete indications on the drawing or by queries of the CAD model, see ISO 16792.
  - The nature of the toleranced feature (linear or areal) is explicitly given by the symbol.
  - To indicate that the specification is an orientation specification, the modifier > < shall be placed in the second compartment of the tolerance indicator, or after each datum indication in the tolerance indicator. The angles between the nominal toleranced feature and the datums shall be indicated as TEDs.

### B.10.4 Location specifications

When a *location* specification uses the geometrical characteristic symbol of:

- Position:
  - The toleranced feature is an integral or a derived feature.
  - If the toleranced feature is an integral feature, the shape of the nominal toleranced feature is a point, a straight line or a plane.
  - If the toleranced feature is a derived feature, the shape of the nominal toleranced feature is a point, a line (straight or non-straight) or a surface (plane or not plane).
  - When more than one is possible then the toleranced feature is by default areal, unless an intersection plane indicator is indicated.

- The angular and linear dimensions between the tolerated feature and the datum or datum-system shall be defined by TEDs. These TEDs are defined explicitly or implicitly by drawing indications.
- Coaxiality/concentricity:
  - The tolerated feature is a derived feature which is nominally a straight line (median line) or a point (centre point).
  - When both are possible then the tolerated feature is by default the line, unless an ACS (Any Cross-section) modifier is indicated.
  - The angular and linear dimensions between the tolerated feature and the datum or datum-system are always  $0^\circ$  and 0 mm.
- Symmetry:
  - The tolerated feature is an integral or a derived feature.
  - If the tolerated feature is an integral feature, the shape of the nominal tolerated feature is a point, a straight line or a plane.
  - If the tolerated feature is a derived feature, the shape of the nominal tolerated feature is a point, a straight line or a plane.
  - When both are possible then the tolerated feature is by default the surface, unless an intersection plane indicator is indicated.
  - The angular and linear dimensions between the tolerated feature and the datum or datum-system are always  $0^\circ$  and 0 mm.
- Surface profile or line profile:
  - This specification is a location specification only when the tolerance indicator refers to at least one datum that can lock a linear distance and no "><" modifier is indicated in the second compartment. Otherwise, this specification is a form or an orientation specification (see [B.10.2](#) and [B.10.3](#)).
  - The shape of the nominal tolerated feature is explicitly given by the complete indications on the drawing or by queries of the CAD model, see ISO 16792.
  - The nature of the nominal tolerated feature (linear or areal) is explicitly given by the symbol.
  - The angular and linear dimensions between the tolerated feature and the datum or datum-system shall be defined by TEDs. These TEDs are defined explicitly or implicitly. All possible linear distances shall be considered between the nominal tolerated feature and a datum indicated in the tolerance indicated, except when the modifier >< is placed after the considered datum.

### B.10.5 Intersection planes

An implicit or explicit intersection plane is used to define the tolerated feature when the geometrical characteristic symbol indicates that the nature of the nominal tolerated feature is a line, or an intersection plane indicator is added to the specification.

It is defined implicitly in the case of:

- Straightness of the generatrix of a cone or a cylinder: The intersection plane is a plane going through the axis of the associated feature established from the extracted integral feature (symmetry plane from the axis);

- Roundness of a sphere or a cylinder: The intersection plane is a plane perpendicular to the derived feature established from the extracted integral feature, when the derived feature is an axis, or a plane including the derived feature, when the derived feature is a point.

In other cases, the intersection plane shall be defined explicitly.

### **B.10.6 Any cross-section**

When the modifier ACS is indicated adjacent to the tolerance indicator, the toleranced feature and the relevant datum are defined in each cross-section independently. The intersection plane defining the toleranced feature is by definition a plane perpendicular to the median feature of the associated feature established from the extracted integral surface.

NOTE The ACS modifier can only be used when the derived feature of the toleranced feature is a line.

## Annex C (informative)

### Filters

#### C.1 Filter symbols

Table C.1 — Filter symbols

Symbol	Designation(s)	Name	ISO document(s)
G	FALG, FPLG	Gaussian	ISO 16610-21, ISO 16610-61
S	FALS, FPLS	Spline	ISO 16610-22, ISO/TS 16610-62 <sup>a</sup>
SW	FALPSW, FPLPSW	Spline Wavelet	ISO 16610-29, ISO/TS 16610-69 <sup>a</sup>
CW	FALPCW, FPLPCW	Complex Wavelet	ISO 16610-29, ISO/TS 16610-69 <sup>a</sup>
RG	FARG, FRPG	Robust Gaussian	ISO/TS 16610-31, ISO 16610-71
RS	FARS, FPRS	Robust Spline	ISO/TS 16610-32, ISO/TS 16610-72 <sup>a</sup>
OB	FAMOB	Opening Ball	ISO/TS 16610-81 <sup>a</sup>
OH	FAMOH, FPMOH	Opening Horizontal Segment	ISO 16610-41, ISO/TS 16610-81 <sup>a</sup>
OD	FPMOD	Opening Disc	ISO 16610-41
CB	FAMCB	Closing Ball	ISO/TS 16610-81 <sup>a</sup>
CH	FAMCH, FPMCH	Closing Horizontal Segment	ISO 16610-41, ISO/TS 16610-81 <sup>a</sup>
CD	FPMCD	Closing Disc	ISO 16610-41
AB	FAMAB	Alternating Ball	ISO/TS 16610-89 <sup>a</sup>
AH	FAMAH, FPMAH	Alternating Horizontal Segment	ISO 16610-49
AD	FPMAD	Alternating Disc	ISO 16610-49
F		Fourier (harmonics)	N/A
H		Hull	N/A

<sup>a</sup> Under development.

## C.2 Nesting indices

Table C.2 — Nesting indices

Symbol	Name	Nesting index
G	Gaussian	Cutoff length Cutoff UPR
S	Spline	Cutoff length Cutoff UPR
SW	Spline Wavelet	Cutoff length Cutoff UPR
CW	Complex Wavelet	Cutoff length Cutoff UPR
RG	Robust Gaussian	Cutoff length Cutoff UPR
RS	Robust Spline	Cutoff length Cutoff UPR
OB	Opening Ball	Ball radius
OH	Opening Horizontal Segment	Segment Length
OD	Opening Disc	Disc radius
CB	Closing Ball	Ball radius
CH	Closing Horizontal Segment	Segment Length
CD	Closing Disc	Disc radius
AB	Alternating Ball	Ball radius
AH	Alternating Horizontal Segment	Segment Length
AD	Alternating Disc	Disc radius
F	Fourier	Wavelength UPR number
H	Hull	H0 indicates the convex hull

NOTE Cutoff length applies to filters for open profiles, Cutoff UPR applies to filters for closed profiles.

## C.3 Filtering in GPS

Filtering has always been utilized in surface texture measurements and has been standardized in that field at least since the publication of ISO 3274:1975. Surface texture parameter values are highly dependent on the filter applied and it is well known that in order to have meaningful control over surface texture, the filtering shall be defined. Currently, ISO 4288:1996 gives the default rules for filters, if the specification does not contain explicit filter setting requirements.

It is similarly well known that measured form deviations change significantly when different filters and cut-off values are applied. This is especially well known for roundness and straightness, because equipment that is able to produce graphical representations of the measured profile and repeat measurements with different filter settings has been available in those areas for several decades.

When ISO 12180, ISO 12181, ISO 12780 and ISO 12781 (“the form standards”) were published as technical specifications in 2003, they were the first ISO GPS documents that were not purely considered



measurement standards that discussed the effect of filtering in the context of the type of specification that is within the scope of this document.

Much discussion took place at the time in an attempt to come to a consensus on what the default filter settings should be for form. However, the differences in philosophy amongst the stakeholders were too great to find a consensus that could attract the necessary majority of votes. This is why there are no defaults in the form standards and why they were initially published as technical specifications and not International Standards.

One of the purposes of this edition of this document is to provide the means to indicate unambiguous filter information in geometrical requirements and enable users of the GPS standards to take advantage of the tools first defined in the form standards in 2003.

While it would be very beneficial to have rules for filter defaults included in this document, it is expected that it would be no easier to reach a consensus today than it was in 2003. It is also recognized that this document contains many valuable tools that would be delayed if an attempt to find a consensus was made before publishing.

Therefore, this document is published without filtering defaults. That way, stakeholders will be able to take advantage of the tools provided and gain experience using these tools. Hopefully, that will enable a consensus for filter defaults in a future edition of this document. In the meantime, tools are provided to conveniently indicate drawing defaults for filtering and association, see [8.6](#).

## Annex D (normative)

### ISO special specification elements for form

**Table D.1 — Association symbols**

Symbol	Association
C	Minimax (Chebyshev)
G	Least squares (Gaussian)
X	Maximum inscribed <sup>a</sup>
N	Minimum circumscribed <sup>a</sup>
E	Constrained external to the material
I	Constrained internal to the material

<sup>a</sup> Only applies to spherical and cylindrical features for form and features of size for datums.

**Table D.2 — Parameter symbols**

Symbol	Parameter
P	Reference-to-peak
V	Reference-to-valley
T	Peak-to-valley
Q	Root mean square (RMS)

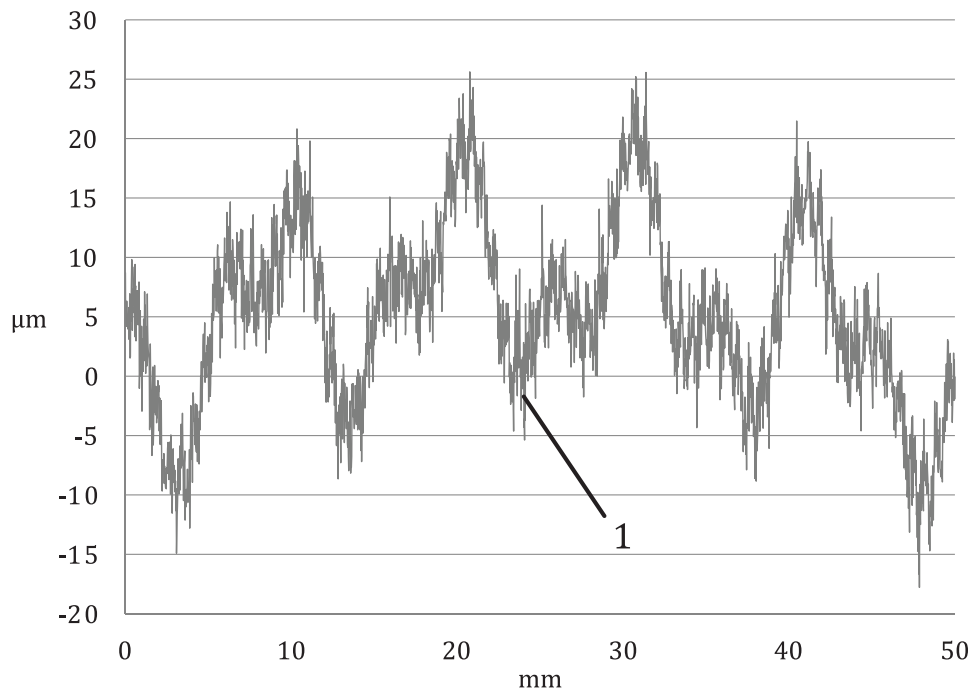
## Annex E (informative)

### Filter details

#### E.1 Introduction to filters

Different workpiece functions interact with the surface of the workpiece in different ways. Some functions may depend on the finest details in the surface, whereas others may depend only on the general shape of the surface. Filters are used to disregard some level of details from a feature, allowing the specification to better define requirements to the remaining surface details. Different filters remove different types of details and can be used to better express different functions with the specification. Some filters tend to disregard the extremes of the surface and focus on the average level of the surface, where other filters tend to focus on either the highest peaks or the lowest valleys in the surface. It is entirely dependent on the function of the surface which filter best describes the functional needs of the surface.

[Figure E.1](#) shows an unfiltered profile, i.e. a line in a surface. The profile is 50 mm long and has a total height range of slightly more than 40  $\mu\text{m}$ . The vertical scale in [Figures E.1](#) to [E.8](#) is magnified compared to the horizontal scale to make the height variations visible. This gives a distorted picture of the profile, making it look rougher than it really is. In the following, profiles are used to illustrate the effect of filters. Filters can also be used for areal features, i.e. planes, cylinders, etc., but for ease of illustration, profiles are used here.



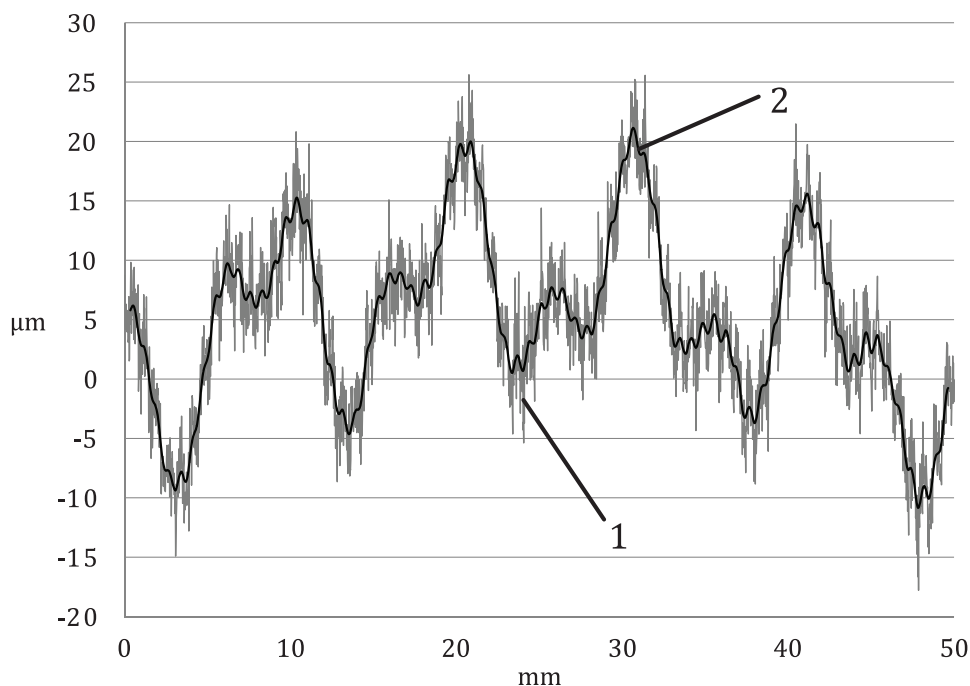
#### Key

1 unfiltered profile

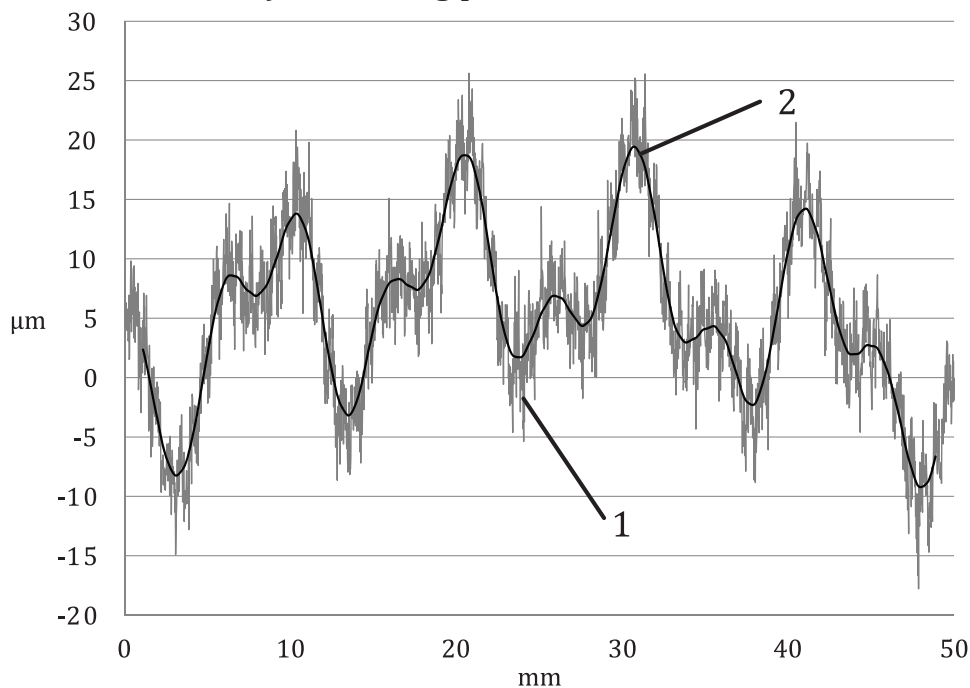
**Figure E.1 — Unfiltered surface profile**

Gaussian, spline and wavelet filters all work in fundamentally the same way. They split the profile in a short-wave portion and a long-wave portion and disregard one or the other. For the purposes of this

document, the most common situation is a long-pass filter, which disregards the short-wave portion of the profile. The nesting index indicates the crossover point in the filter between what it disregards and what it retains. [Figure E.2](#) shows the same profile as in [Figure E.1](#) after the application of a long pass Gaussian filter.



**a) 0,8 mm long-pass Gaussian filter**



**b) 2,5 mm long-pass Gaussian filter**

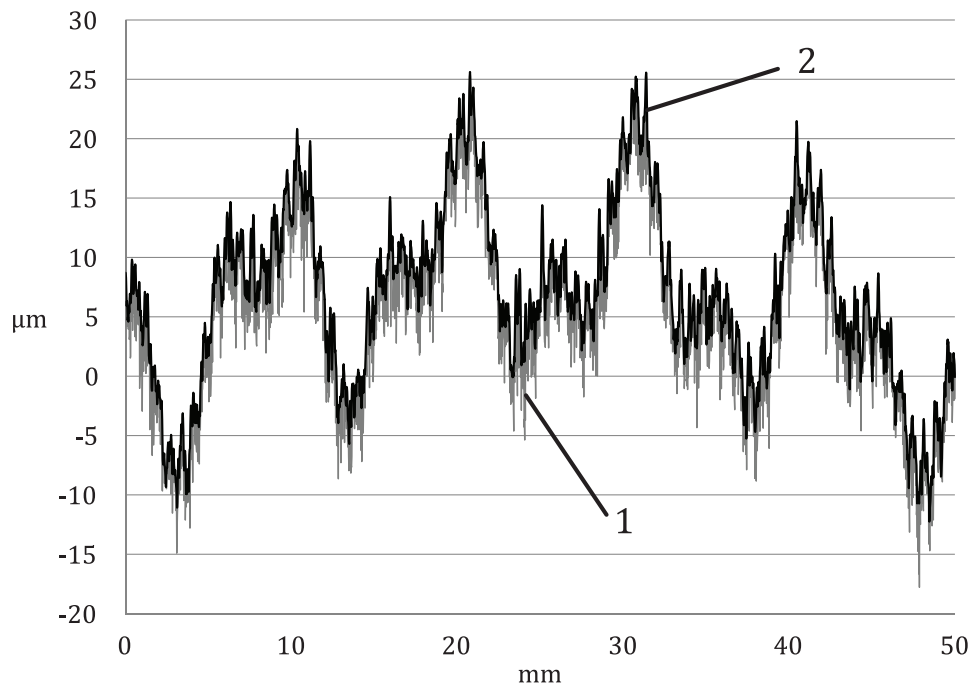
**Key**

- 1 unfiltered profile (grey)
- 2 filtered profile (black)

**Figure E.2 — Surface profile filtered with a Gaussian filter**

The filtered profile in [Figure E.2 a\)](#) has more detail included than the filtered profile in [Figure E.2 b\)](#), but the overall shape of the filtered profile and the amplitude of the deviations are similar in the two figures. The difference in cutoff length between 0,8 mm and 2,5 mm does not make a significant difference for this particular profile, they both have a total height range of about 30  $\mu\text{m}$ . Also, [Figure E.2](#) shows that the Gaussian filter, like the spline and wavelet filters, create a filtered profile that is in the middle of the unfiltered profile.

[Figure E.3](#) shows the same profile as in [Figure E.1](#) after the application of a closing disc filter with a 0,5 mm radius disc as the structuring element. A closing ball filter simulates rolling a ball of a certain diameter over the surface. The ball will contact all the highest peaks in the surface, but will not be able to penetrate into the deepest valleys, thus filtering these out of the profile.



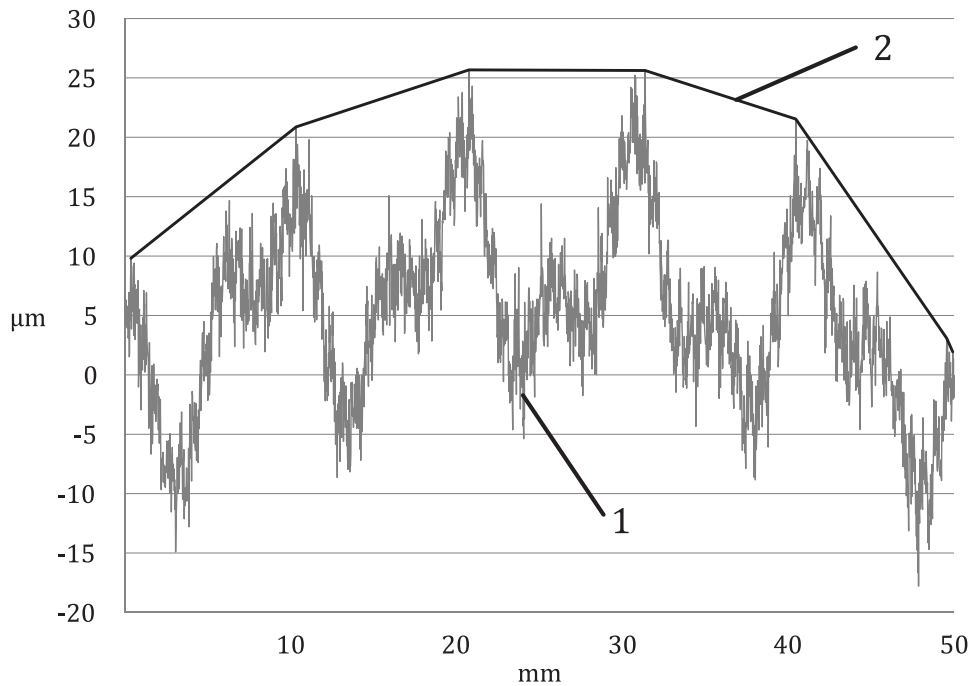
#### Key

- 1 unfiltered profile (grey)
- 2 filtered profile (black)

**Figure E.3 — Surface profile filtered with a closing ball filter**

The closing ball filter is also a long-pass filter that removes some of the short-wave detail of the profile. In this case, the resulting filtered profile has a total height range of about 35  $\mu\text{m}$ , but in contrast to the Gaussian filter, it retains the highest peaks in the surface. This is useful if the function depends on the location of these peaks.

[Figure E.4](#) shows the same profile as in [Figure E.1](#) after the application of a hull filter. The hull filter is equivalent to stretching a piece of rubber over the surface. It retains the highest peaks in the profile and connects them with straight lines (for profiles, triangular facets for surfaces).



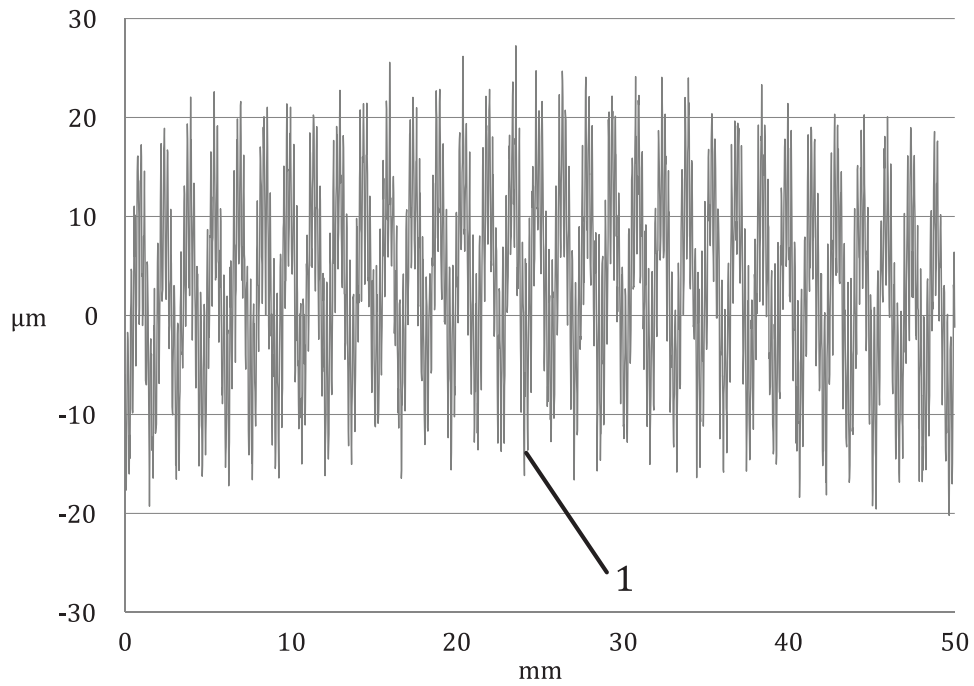
**Key**

- 1 unfiltered profile
- 2 filtered profile

**Figure E.4 — Surface profile filtered with a convex hull filter**

The convex hull filter is a long-pass filter. It removes almost all the details in the profile and considers only the highest peaks. In this case, the resulting filtered profile also has a total height range of about 25  $\mu\text{m}$ .

[Figure E.5](#) shows a different surface profile. Like the profile in [Figure E.1](#) it is 50 mm long and has a total height range of slightly more than 40  $\mu\text{m}$ , but the structure of the surface is different.

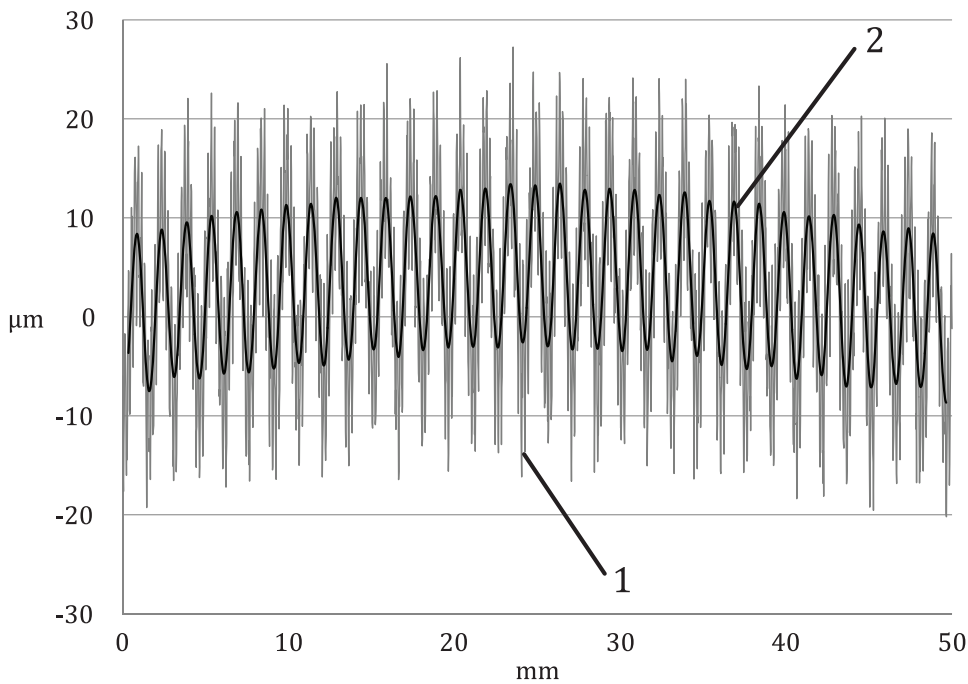


**Key**

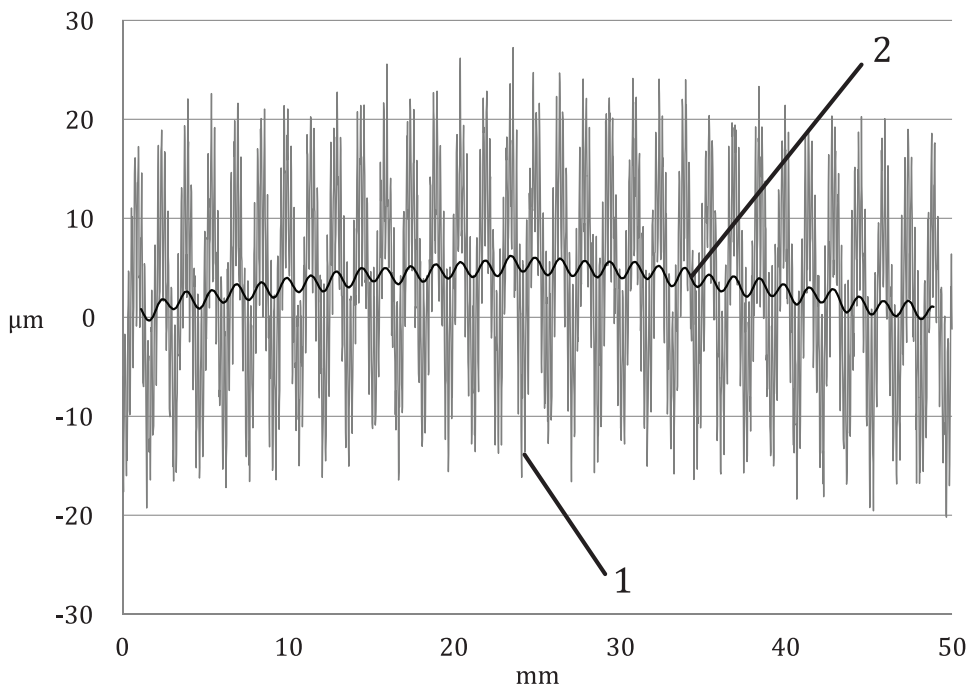
- 1 unfiltered profile

**Figure E.5 — Unfiltered surface profile**

Without filtering, the profiles in [Figure E.1](#) and [E.5](#) would pass the same specifications and fail the same specifications.



a) 0,8 mm long-pass Gaussian filter



b) 2,5 mm long-pass Gaussian filter

**Key**

- 1 unfiltered profile (grey)
- 2 filtered profile (black)

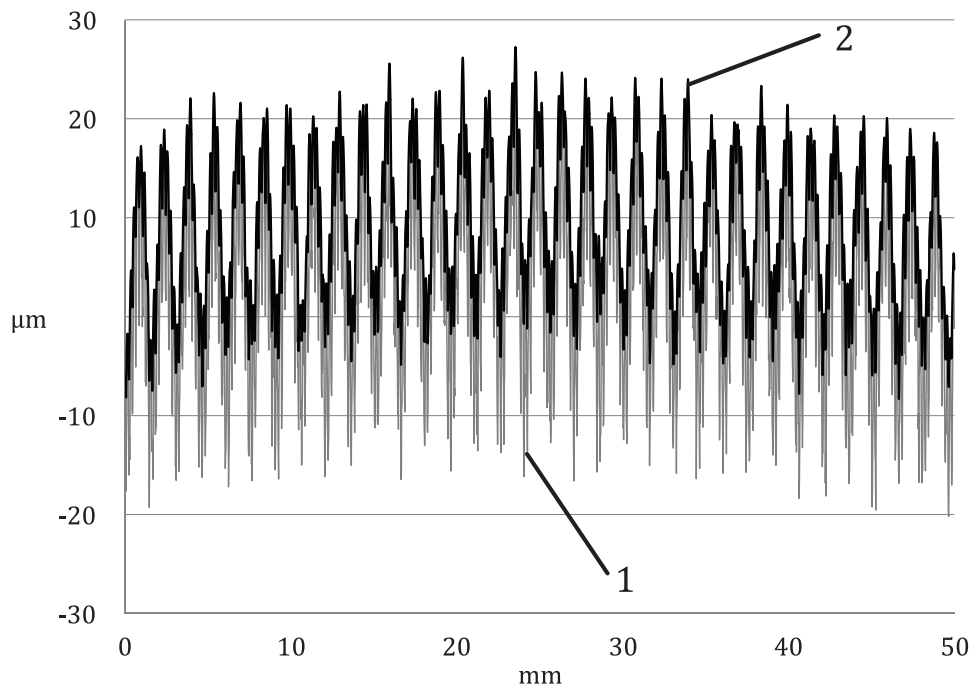
**Figure E.6 — Surface profile filtered with a Gaussian filter**

Again, the filtered profile in [Figure E.6 a\)](#) with the shorter cutoff length has more detail included than the filtered profile in [Figure E.6 b\)](#), but in this case, the height ranges are significantly different. The



filtered profile in [Figure E.6 a\)](#) has a height range of about  $20\ \mu\text{m}$ , whereas the one in [Figure E.6 b\)](#) has a height range of about  $5\ \mu\text{m}$ . So if the profile in [Figure E.5](#) is functionally acceptable, but the profile in [Figure E.1](#) is not, then a Gaussian filter with a cutoff length of  $2,5\ \text{mm}$  is suitable for distinguishing between the two, whereas a Gaussian filter with a cutoff length of  $0,8\ \text{mm}$  is only able to show a marginal difference between the two profiles.

[Figure E.7](#) shows the same profile as in [Figure E.5](#) after the application of a closing disc filter with a  $0,5\ \text{mm}$  radius disc as the structuring element.



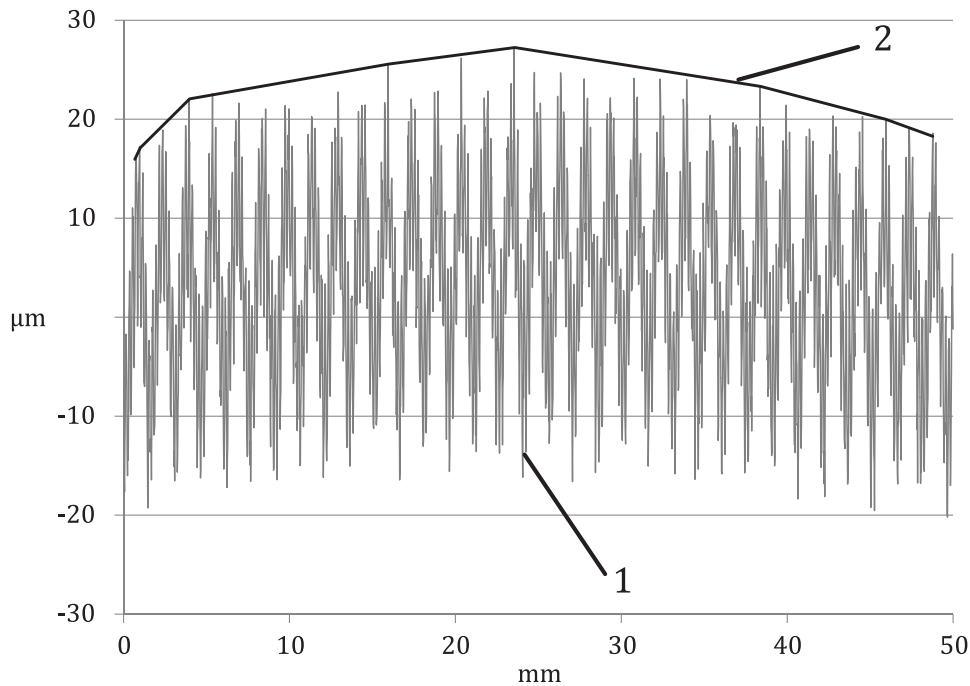
#### Key

- 1 unfiltered profile (grey)
- 2 filtered profile (black)

**Figure E.7 — Surface profile filtered with a closing ball filter**

The resulting filtered profile also has a total height range of about  $35\ \mu\text{m}$ , so the  $1\ \text{mm}$  diameter closing ball filter cannot tell the two profiles apart. Using a larger ball diameter for the structuring element would have made a difference. So a closing ball filter with a larger size of the structuring element would be appropriate, if the function depends on the location of the peaks and the profile in [Figure E.1](#) is not acceptable, but the profile in [Figure E.5](#) is acceptable, provided the peaks are in the correct location.

[Figure E.8](#) shows the same profile as in [Figure E.5](#) after the application of a hull filter.



- Key**
- 1 unfiltered profile
  - 2 filtered profile

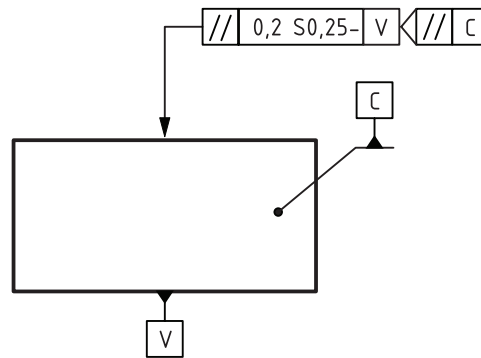
**Figure E.8 — Surface profile filtered with a convex hull filter**

In this case, the resulting filtered profile has a total height range of about 10 µm, so the convex hull filter can also tell the two profiles apart. Therefore, a convex hull filter would be appropriate, if the function depends on the location of the peaks and the profile in [Figure E.1](#) is not acceptable, but the profile in [Figure E.5](#) is acceptable, provided the peaks are in the correct location. In this particular case, the convex hull filter sees a larger difference between the two profiles than the closing ball filter does.

For further information, see the ISO 16610 series of standards, in particular ISO 16610-1.

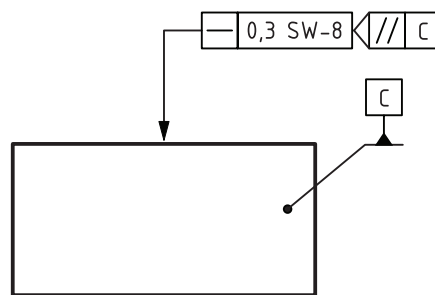
## E.2 Examples of specifications using filters

[Figure E.9](#) shows an example of a parallelism specification with a long-wave pass filter. The specification element S indicates that a spline filter is specified. The value 0,25 indicates a 0,25 mm cutoff and because the “-” follows the value, it is a long-wave pass filter, which removes wavelengths shorter than the cutoff value. The specification therefore applies to a feature that has been filtered with a 0,25 mm long-wave pass spline filter. The intersection plane indicator adjacent to the tolerance indicator indicates that the specification applies to line elements parallel to datum C, so each individual filtered line shall be parallel to datum V within a tolerance zone defined as the space between two lines 0,2 mm apart.



**Figure E.9 — Example of a parallelism specification with a long-wave pass filter**

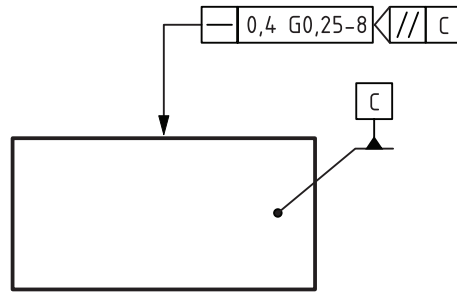
[Figure E.10](#) shows an example of a straightness specification with a short-wave pass filter. The specification element SW indicates that a spline wavelet filter is specified. The value 8 indicates an 8 mm cutoff and because it is preceded by “-” it is a short-wave pass filter, which removes wavelengths longer than the cutoff value. The specification therefore applies to a feature that has been filtered with an 8 mm short-wave pass spline wavelet filter. The intersection plane indicator adjacent to the tolerance indicator indicates that the specification applies to line elements parallel to datum C, so each individual filtered line shall be straight within a tolerance zone defined as the space between two lines 0,3 mm apart.



**Figure E.10 — Example of a straightness specification with a short-wave pass filter**

Short-wave pass filters can only be used for form specifications, i.e. specifications that do not reference datums, because they remove the location and orientation attributes from the toleranced feature.

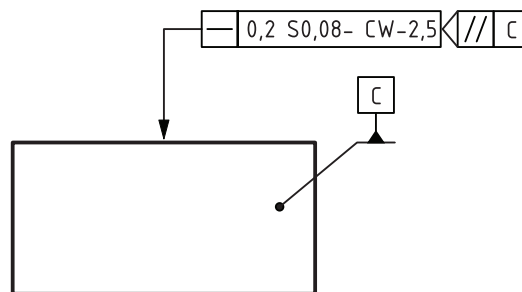
[Figure E.11](#) shows an example of a straightness specification with a band pass filter using one filter type. The specification element G indicates that a Gaussian filter is specified. Because there are two numerical values separated by a “-”, this specifies a band pass filter. The first value, 0,25, indicates a 0,25 mm cutoff long-wave pass filter, which removes wavelengths shorter than the cutoff value. The value 8 indicates an 8 mm cutoff short-wave pass filter, which removes wavelengths longer than the cutoff value. The specification therefore applies to a feature that has been filtered with a 0,25 mm long-wave pass Gaussian filter and an 8 mm short-wave pass Gaussian filter, which together form a band pass filter that retains wavelengths between 0,25 mm and 8 mm, effectively making this a type of waviness specification. The intersection plane indicator adjacent to the tolerance indicator indicates that the specification applies to line elements parallel to datum C, so each individual filtered line shall be straight within a tolerance zone defined as the space between two lines 0,4 mm apart.



**Figure E.11 — Example of a straightness specification with a band pass filter using one filter type**

Because band pass filters include a short-wave pass filter, they can only be used for form specifications, i.e. specifications that do not reference datums, because short-wave pass filters remove the location and orientation attributes from the toleranced feature.

[Figure E.12](#) shows an example of a straightness specification with a band pass filter using two different filter types. The long-wave pass filter shall be written before the short-wave pass filter. The specification element S indicates that a spline filter is specified. The value 0,08 indicates a 0,08 mm cutoff and because the “-” follows the value, it is a long-wave pass filter, which removes wavelengths shorter than the cutoff value. The specification element CW indicates that a complex wavelet filter is specified. The value 2,5 indicates a 2,5 mm cutoff and because it is preceded by “-” it is a short-wave pass filter, which removes wavelengths longer than the cutoff value. The specification applies to a feature that has been filtered with a 0,08 mm long-wave pass spline filter and a 2,5 mm short-wave pass complex wavelet filter, which together form a band pass filter that retains wavelengths between 0,08 mm and 2,5 mm, effectively making this a type of waviness specification. The intersection plane indicator adjacent to the tolerance indicator indicates that the specification applies to line elements parallel to datum C, so each individual filtered line shall be straight within a tolerance zone defined as the space between two lines 0,2 mm apart.



**Figure E.12 — Example of a straightness specification with a band pass filter using two different filter types**

[Figure E.13](#) shows an example of a roundness specification. The specification element G indicates that a Gaussian filter is specified. Because it is a roundness specification, the toleranced feature is considered a closed feature and the nesting index is therefore given in UPR (undulations per revolution). The value 50 therefore indicates 50 UPR and because it is followed by “-” it is a long-wave pass filter, which removes short wavelengths (higher UPR numbers). The specification therefore applies to a feature that has been filtered with a 50 UPR Gaussian long-wave pass filter. Each individual filtered circumferential line shall be contained in a tolerance zone defined as the space between two concentric circles with 0,01 mm radius difference.

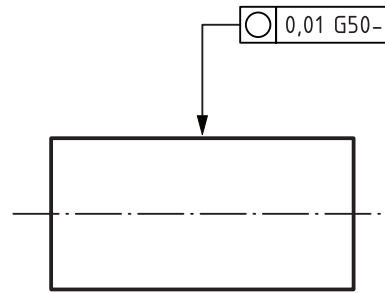


Figure E.13 — Example of a roundness specification — Gaussian filter

Figure E.14 shows an example of a cylindricity specification. The specification element CB indicates that a closing ball filter is specified. The value “1,5” indicates that a 1,5 mm radius ball shall be used as the structuring element and because it is followed by “-” it is a long-wave pass filter, which removes short wavelengths. The filtered surface shall be contained in a tolerance zone defined as the space between two coaxial cylinders with a 0,05 mm radius difference.

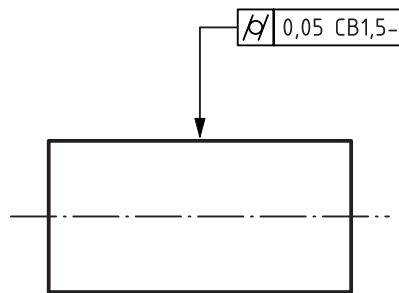


Figure E.14 — Example of a cylindricity specification — Closing ball filter

Figure E.15 shows an example of a flatness specification with two different long-wave pass filters. The first specification element S indicates that a spline filter is specified in the direction indicated by the intersection plane. The value 0,25 indicates a 0,25 mm cutoff and because it is followed by “-” it is a long-wave pass filter, which removes wavelengths shorter than the cutoff value. “x” is used to separate the two filter indications. The second specification element G indicates that a Gaussian filter is specified in the direction perpendicular to the direction indicated by the intersection plane. The value 0,8 indicates a 0,8 mm cutoff and because it is followed by “-” it is a long-wave pass filter, which removes wavelengths shorter than the cutoff value. The specification therefore applies to a feature that has been filtered with a 0,25 mm long-wave pass spline filter in one direction and a 0,8 mm long-wave pass Gaussian filter in the perpendicular direction. The filtered surface shall be contained between two planes 0,02 mm apart.

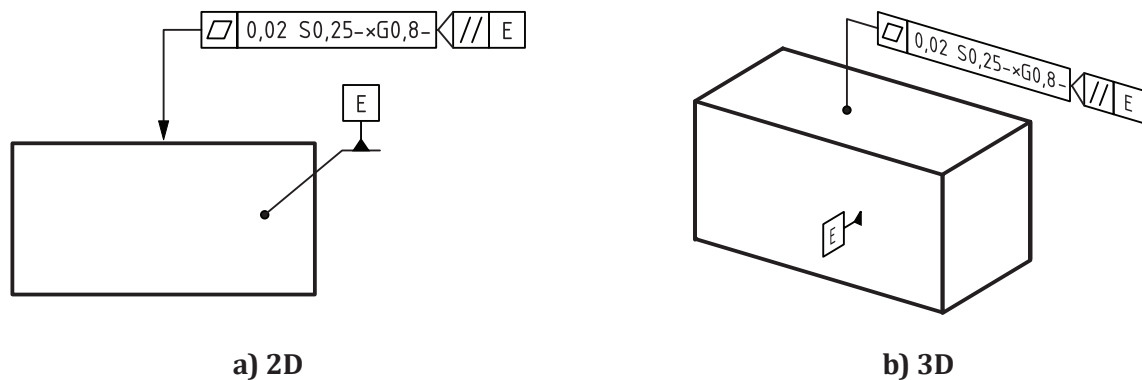


Figure E.15 — Example of a flatness specification with two different long-wave pass filters

Figure E.16 shows an example of a cylindricity specification. The specification element G indicates that a Gaussian filter is specified. Because it is a cylindricity specification, the tolerated feature is an open feature in the axial direction and a closed feature in the circumferential direction. The nesting index in the axial direction is therefore given in mm and the nesting index in the circumferential direction is given in UPR. By convention, the axial filter value is given before the circumferential filter value. The value 8 therefore indicates 8 mm and the value 15 indicates 15 UPR. Because each of them is followed by “-” they are both long-wave pass filters. The specification therefore applies to a feature that has been filtered with an 8 mm Gaussian long-wave pass filter in the axial direction and a 15 UPR Gaussian long-wave pass filter in the circumferential direction. The filtered surface shall be contained in a tolerance zone defined as the space between two coaxial cylinders with a 0,05 mm radius difference. Because both filters are of the same type, the type is not indicated twice as it was in Figure E.15.

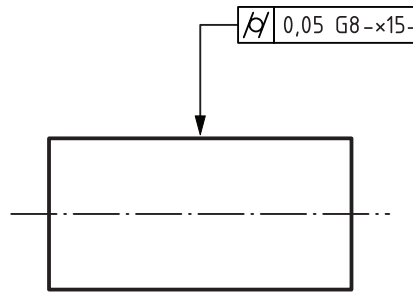


Figure E.16 — Example of a cylindricity specification — Gaussian filter

Figure E.17 shows an example of a roundness specification. The specification element F (Fourier) indicates that the specification applies to a single harmonic (wavelength or UPR number) or a range of harmonics. The value 7 indicates 7 UPR as the identified harmonic, as the specification applies to a closed feature (a circle). The specification therefore applies to the 7th harmonic of the feature. Each individual filtered circumferential line shall be contained in a tolerance zone defined as the space between two concentric circles with 0,02 mm radius difference.

NOTE Because UPR values are reverse of wavelengths and the short wavelength is indicated first, the higher UPR value is indicated first for band-pass filters for closed features.

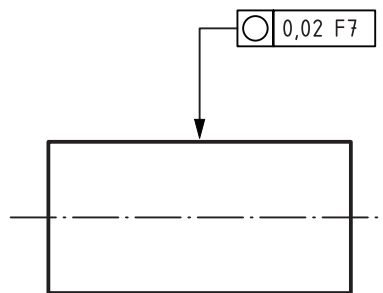
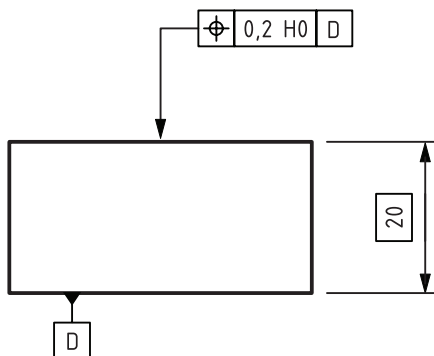


Figure E.17 — Example of a roundness specification that applied to a single or a range of harmonics

An indication of e.g. “F7-” shall be used to indicate that the specification applies to a filtered feature that includes all harmonics longer than (lower UPR numbers) or equal to the indicated value, in this case all harmonics from 1 UPR to 7 UPR. An indication of e.g. “F-7” shall be used to indicate that the specification applies to a filtered feature that includes all harmonics shorter than (higher UPR numbers) or equal to the indicated value, in this case all harmonics from 7 UPR and higher. An indication of e.g. “F7-2” shall be used to indicate that the specification applies to a filtered feature that includes the indicated range of harmonics, in this case all harmonics from 2 UPR to 7 UPR.

Figure E.18 shows an example of a position specification. The specification element H indicates that the specification applies to the feature after the application of a hull filter. The value 0 indicates that the

filter is the convex hull filter. The filtered surface shall be contained between two planes 0,2 mm apart, in the theoretically correct orientation and location relative to datum D.



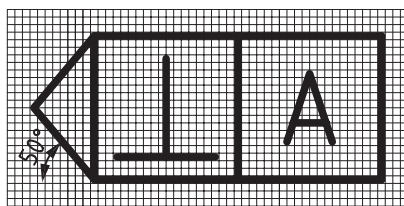
**Figure E.18 — Example of a position specification**

## Annex F (normative)

### Relations and dimensions of graphical symbols

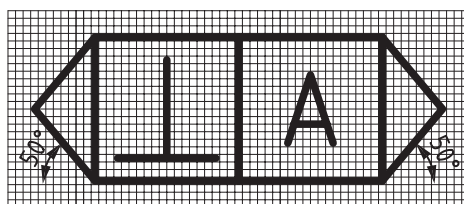
To harmonize the sizes of the symbols specified in this document with those of the other inscriptions on the drawing (dimensions, letters, tolerances), the rules given in this annex, which are in accordance with ISO 81714-1, shall be observed. Further graphical symbols are given in ISO 3098-5.

The graphical symbols described in [Table 2](#) shall be drawn in accordance with [Figures F.1](#) to [F.5](#).



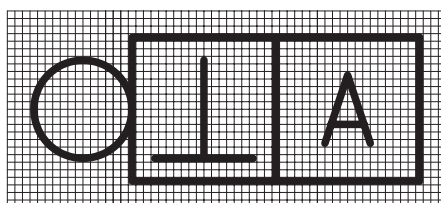
NOTE The leftmost point of the intersection plane indicator shall touch the tolerance indicator, see e.g. [Figure 77](#).

**Figure F.1 — Intersection plane indicator**



NOTE The leftmost point of the orientation plane indicator shall touch the tolerance indicator or the intersection plane indicator, see e.g. [Figure 83](#).

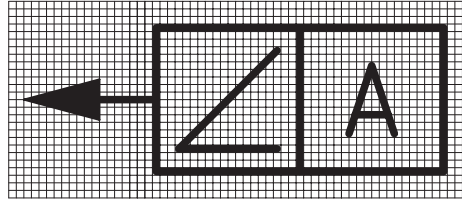
**Figure F.2 — Orientation plane indicator**



NOTE The leftmost point of the collection plane indicator shall touch the tolerance indicator or the intersection plane indicator, see e.g. [Figure 51 a\)](#) and [b\)](#).

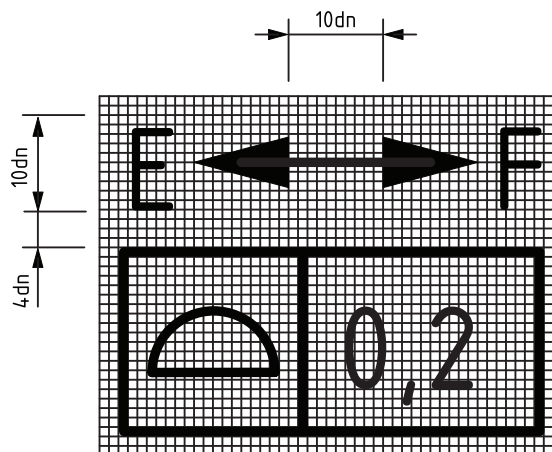
**Figure F.3 — Collection plane indicator**





NOTE The leftmost point of the direction feature indicator shall touch the tolerance indicator or any plane indicator indicated, see e.g. [Figure 85](#).

Figure F.4 — Direction feature indicator



NOTE  $dn$  is the width of the narrow line.

Figure F.5 — “Between” symbol

## Annex G (informative)

### Relation to the GPS matrix model

#### G.1 General

For full details about the GPS matrix model, see ISO 14638.

The ISO GPS Masterplan given in ISO 14638 gives an overview of the ISO GPS system of which this document is a part. The fundamental rules of ISO GPS given in ISO 8015 apply to this document. The default decision rules given in ISO 14253-1 apply to specifications made in accordance with this document, unless otherwise stated.

#### G.2 Information about the standard and its use

This document contains basic information for the geometrical tolerancing of workpieces. It represents the initial basis and describes the fundamentals for geometrical tolerancing.

#### G.3 Position in the GPS matrix model

This document is a general GPS standard, which influences the chain link A, B and C of the chains of standards on form, orientation, location and run out in the general GPS matrix, as graphically illustrated in [Table G.1](#).

**Table G.1 — Position in the GPS matrix model**

	Chain links						
	A	B	C	D	E	F	G
	Symbols and indications	Feature requirements	Feature properties	Conformance and non-conformance	Measurement	Measurement equipment	Calibration
Size							
Distance							
Form	•	•	•				
Orientation	•	•	•				
Location	•	•	•				
Run-out	•	•	•				
Profile surface texture							
Areal surface texture							
Surface imperfections							

#### G.4 Related standards

The related standards are those of the chains of standards indicated in [Table G.1](#).

## Bibliography

- [1] ISO 128 (all parts), *Technical drawings — General principles of presentation*
- [2] ISO 129 (all parts), *Technical drawings — Indication of dimensions and tolerances*
- [3] ISO 3040:1990, *Technical drawings — Dimensioning and tolerancing — Cones*
- [4] ISO 3098-1, *Technical product documentation — Lettering — Part 1: General requirements*
- [5] ISO 3098-2:2000, *Technical product documentation — Lettering — Part 2: Latin alphabet, numerals and marks*
- [6] ISO 3098-5, *Technical product documentation — Lettering — Part 5: CAD lettering of the Latin alphabet, numerals and marks*
- [7] ISO 7083:1983, *Technical drawings — Symbols for geometrical tolerancing — Proportions and dimensions*
- [8] ISO 14253-1, *Geometrical product specifications (GPS) — Inspection by measurement of workpieces and measuring equipment — Part 1: Decision rules for verifying conformity or nonconformity with specifications*
- [9] ISO 14638, *Geometrical product specification (GPS) — Matrix model*
- [10] ISO 16792, *Technical product documentation — Digital product definition data practices*
- [11] ISO 17863:2013, *Geometrical product specification (GPS) — Tolerancing of moveable assemblies*
- [12] ISO 81714-1, *Design of graphical symbols for use in the technical documentation of products — Part 1: Basic rules*





# British Standards Institution (BSI)

BSI is the national body responsible for preparing British Standards and other standards-related publications, information and services.

BSI is incorporated by Royal Charter. British Standards and other standardization products are published by BSI Standards Limited.

## About us

We bring together business, industry, government, consumers, innovators and others to shape their combined experience and expertise into standards-based solutions.

The knowledge embodied in our standards has been carefully assembled in a dependable format and refined through our open consultation process. Organizations of all sizes and across all sectors choose standards to help them achieve their goals.

## Information on standards

We can provide you with the knowledge that your organization needs to succeed. Find out more about British Standards by visiting our website at [bsigroup.com/standards](http://bsigroup.com/standards) or contacting our Customer Services team or Knowledge Centre.

## Buying standards

You can buy and download PDF versions of BSI publications, including British and adopted European and international standards, through our website at [bsigroup.com/shop](http://bsigroup.com/shop), where hard copies can also be purchased.

If you need international and foreign standards from other Standards Development Organizations, hard copies can be ordered from our Customer Services team.

## Copyright in BSI publications

All the content in BSI publications, including British Standards, is the property of and copyrighted by BSI or some person or entity that owns copyright in the information used (such as the international standardization bodies) and has formally licensed such information to BSI for commercial publication and use.

Save for the provisions below, you may not transfer, share or disseminate any portion of the standard to any other person. You may not adapt, distribute, commercially exploit, or publicly display the standard or any portion thereof in any manner whatsoever without BSI's prior written consent.

## Storing and using standards

Standards purchased in soft copy format:

- A British Standard purchased in soft copy format is licensed to a sole named user for personal or internal company use only.
- The standard may be stored on more than 1 device provided that it is accessible by the sole named user only and that only 1 copy is accessed at any one time.
- A single paper copy may be printed for personal or internal company use only.

Standards purchased in hard copy format:

- A British Standard purchased in hard copy format is for personal or internal company use only.
- It may not be further reproduced – in any format – to create an additional copy. This includes scanning of the document.

If you need more than 1 copy of the document, or if you wish to share the document on an internal network, you can save money by choosing a subscription product (see 'Subscriptions').

## Reproducing extracts

For permission to reproduce content from BSI publications contact the BSI Copyright & Licensing team.

## Subscriptions

Our range of subscription services are designed to make using standards easier for you. For further information on our subscription products go to [bsigroup.com/subscriptions](http://bsigroup.com/subscriptions).

With **British Standards Online (BSOL)** you'll have instant access to over 55,000 British and adopted European and international standards from your desktop. It's available 24/7 and is refreshed daily so you'll always be up to date.

You can keep in touch with standards developments and receive substantial discounts on the purchase price of standards, both in single copy and subscription format, by becoming a **BSI Subscribing Member**.

**PLUS** is an updating service exclusive to BSI Subscribing Members. You will automatically receive the latest hard copy of your standards when they're revised or replaced.

To find out more about becoming a BSI Subscribing Member and the benefits of membership, please visit [bsigroup.com/shop](http://bsigroup.com/shop).

With a **Multi-User Network Licence (MUNL)** you are able to host standards publications on your intranet. Licences can cover as few or as many users as you wish. With updates supplied as soon as they're available, you can be sure your documentation is current. For further information, email [subscriptions@bsigroup.com](mailto:subscriptions@bsigroup.com).

## Revisions

Our British Standards and other publications are updated by amendment or revision.

We continually improve the quality of our products and services to benefit your business. If you find an inaccuracy or ambiguity within a British Standard or other BSI publication please inform the Knowledge Centre.

## Useful Contacts

### Customer Services

**Tel:** +44 345 086 9001

**Email (orders):** [orders@bsigroup.com](mailto:orders@bsigroup.com)

**Email (enquiries):** [cservices@bsigroup.com](mailto:cservices@bsigroup.com)

### Subscriptions

**Tel:** +44 345 086 9001

**Email:** [subscriptions@bsigroup.com](mailto:subscriptions@bsigroup.com)

### Knowledge Centre

**Tel:** +44 20 8996 7004

**Email:** [knowledgecentre@bsigroup.com](mailto:knowledgecentre@bsigroup.com)

### Copyright & Licensing

**Tel:** +44 20 8996 7070

**Email:** [copyright@bsigroup.com](mailto:copyright@bsigroup.com)

### BSI Group Headquarters

389 Chiswick High Road London W4 4AL UK